

STATE OF NORTH CAROLINA
DEPARTMENT OF TRANSPORTATION
HIGHWAY DIVISION 3

PROPOSAL

DATE AND TIME OF BID OPENING: August 18, 2022 AT 2:00 PM

CONTRACT ID: D3POC0144

WBS ELEMENT NO.: VARIOUS

FEDERAL AID NO.: FEDERAL PROVISIONS

COUNTY: Brunswick, Duplin, New Hanover, Onslow, Pender and Sampson
Counties

TIP NO.: N/A

MILES: VARIOUS MILES

ROUTE NO.: VARIOUS

LOCATION: VARIOUS INTERSECTIONS THROUGHOUT DUPLIN,
ONSLow, PENDER, SAMPSON, BRUNSWICK & NEW HANOVER COUNTIES

TYPE OF WORK: ON CALL SIGNAL & ITS MAINTENANCE *FEDERAL WORK
ONLY*

NOTICE:

ALL BIDDERS SHALL COMPLY WITH ALL APPLICABLE LAWS REGULATING THE PRACTICE OF GENERAL CONTRACTING AS CONTAINED IN CHAPTER 87 OF THE GENERAL STATUTES OF NORTH CAROLINA WHICH REQUIRES THE BIDDER TO BE LICENSED BY THE N.C. LICENSING BOARD FOR CONTRACTORS WHEN BIDDING ON ANY NON-FEDERAL AID PROJECT WHERE THE BID IS \$30,000 OR MORE, EXCEPT FOR CERTAIN SPECIALTY WORK AS DETERMINED BY THE LICENSING BOARD. BIDDERS SHALL ALSO COMPLY WITH ALL OTHER APPLICABLE LAWS REGULATING THE PRACTICES OF ELECTRICAL, PLUMBING, HEATING AND AIR CONDITIONING AND REFRIGERATION CONTRACTING AS CONTAINED IN CHAPTER 87 OF THE GENERAL STATUTES OF NORTH CAROLINA. NOTWITHSTANDING THESE LIMITATIONS ON BIDDING, THE BIDDER WHO IS AWARDED ANY FEDERAL - AID FUNDED PROJECT SHALL COMPLY WITH CHAPTER 87 OF THE GENERAL STATUTES OF NORTH CAROLINA FOR LICENSING REQUIREMENTS WITHIN 60 CALENDAR DAYS OF BID OPENING.

THIS IS A ROADWAY PROJECT.

BID BONDS ARE NOT REQUIRED.

NAME OF BIDDER

ADDRESS OF BIDDER

**PROPOSAL FOR THE CONSTRUCTION OF
CONTRACT No. D3POC0144 IN BRUNSWICK, DUPLIN, NEW HANOVER, ONSLOW, PENDER AND
SAMPSON COUNTIES, NORTH CAROLINA**

Date _____ **20** _____

**DEPARTMENT OF TRANSPORTATION,
RALEIGH, NORTH CAROLINA**

The Bidder has carefully examined the location of the proposed work to be known as Contract No. **D3POC0144**; has carefully examined the plans and specifications, which are acknowledged to be part of the proposal, the special provisions, the proposal, the form of contract, and the forms of contract payment bond and contract performance bond; and thoroughly understands the stipulations, requirements and provisions. The undersigned bidder agrees to bound upon his execution of the bid and subsequent award to him by the Department of Transportation in accordance with this proposal to provide the necessary contract payment bond and contract performance bond within fourteen days after the written notice of award is received by him. The undersigned Bidder further agrees to provide all necessary machinery, tools, labor, and other means of construction; and to do all the work and to furnish all materials, except as otherwise noted, necessary to perform and complete the said contract in accordance with *the 2018 Standard Specifications for Roads and Structures* by the dates(s) specified in the Project Special Provisions and in accordance with the requirements of the Engineer, and at the unit or lump sum prices, as the case may be, for the various items given on the sheets contained herein.

The Bidder shall provide and furnish all the materials, machinery, implements, appliances and tools, and perform the work and required labor to construct and complete State Highway Contract No. **D3POC0144** in **Brunswick, Duplin, New Hanover, Onslow, Pender and Sampson Counties**, for the unit or lump sum prices, as the case may be, bid by the Bidder in his bid and according to the proposal, plans, and specifications prepared by said Department, which proposal, plans, and specifications show the details covering this project, and hereby become a part of this contract.

The published volume entitled *North Carolina Department of Transportation, Raleigh, Standard Specifications for Roads and Structures, January 2018* with all amendments and supplements thereto, is by reference incorporated into and made a part of this contract; that, except as herein modified, all the construction and work included in this contract is to be done in accordance with the specifications contained in said volume, and amendments and supplements thereto, under the direction of the Engineer.

If the proposal is accepted and the award is made, the contract is valid only when signed either by the Contract Officer or such other person as may be designated by the Secretary to sign for the Department of Transportation. The conditions and provisions herein cannot be changed except over the signature of the said Contract Officer or Division Engineer.

The quantities shown in the itemized proposal for the project are considered to be approximate only and are given as the basis for comparison of bids. The Department of Transportation may increase or decrease the quantity of any item or portion of the work as may be deemed necessary or expedient.

An increase or decrease in the quantity of an item will not be regarded as sufficient ground for an increase or decrease in the unit prices, nor in the time allowed for the completion of the work, except as provided for the contract.

TABLE OF CONTENTS

THIS CONTRACT IS FOR CONTRACT ID **D3POC0144** FOR **ON CALL SIGNAL & ITS MAINTENANCE *FEDERAL WORK ONLY*** TYPE OF WORK IN **Brunswick, Duplin, New Hanover, Onslow, Pender and Sampson Counties.**

SPECIAL PROVISIONS

PROJECT SPECIAL PROVISIONS.....	1
GENERAL.....	1
MANDATORY PRE-BID CONFERENCE AND PROPOSAL REVIEW:.....	1
CONTRACT TIME FOR ID/IQ:.....	2
INTERMEDIATE CONTRACT TIME NUMBER 1 AND LIQUIDATED DAMAGES:	2
NO MAJOR CONTRACT ITEMS:	3
SPECIALTY ITEMS:.....	4
FUEL PRICE ADJUSTMENT PAPER BID:	4
SCHEDULE OF ESTIMATED COMPLETION PROGRESS:.....	5
DISADVANTAGED BUSINESS ENTERPRISE (DIVISIONS):.....	5
MULTI-YEAR MAINTENANCE CONTRACTS (ID/IQ):	17
CERTIFICATION FOR FEDERAL-AID CONTRACTS:	18
CONTRACTOR'S LICENSE REQUIREMENTS:.....	18
RESTRICTIONS ON ITS EQUIPMENT AND SERVICES:.....	18
USE OF UNMANNED AIRCRAFT SYSTEM (UAS):	19
EQUIPMENT IDLING GUIDELINES:.....	19
U.S. DEPARTMENT OF TRANSPORTATION HOTLINE:	20
CARGO PREFERENCE ACT:	20
AWARD LIMITS:.....	21
WORK ORDER ASSIGNMENT (SINGLE AWARDS) FOR ID/IQ:	21
BONDING REQUIREMENTS FOR ID/IQ:.....	22
MOBILIZATION AND LIQUIDATED DAMAGES FOR ID/IQ:.....	23
EMERGENCY MOBILIZATION FOR ID/IQ:.....	23
RENEWAL OF CONTRACT (CPI PRICE ADJUSTMENT) FOR ID/IQ:	24
DISPUTE RESOLUTION PROCESS FOR ID/IQ:	25
PROJECT SPECIAL PROVISIONS.....	26
ROADWAY.....	26
NOTES TO CONTRACTOR:	26
BURNING RESTRICTIONS:.....	27
LABOR ASSISTANCE ON AN "AS NEEDED BASIS"	27
TEMPORARY TRAFFIC CONTROL (TTC).....	28
2.00 LIGHT STANDARD LIGHT EMITTING DIODE (LED) LUMINAIRES.....	33
BREAKAWAY FUSE HOLDER	37
SITE SURVEY	37
NEW ELECTRICAL SERVICE	37
CCTV CAMERA ASSEMBLY:	39
REPLACE PEDESTRIAN PUSH BUTTONS.....	43
ADJUST SPAN & GUY WIRE ATTACHMENTS.....	43
ANCHOR BOLTS AND TEMPLATES	44

TRAFFIC SIGNAL WOOD POLE REMOVAL	44
VEHICLE SIGNAL HEAD REMOVAL.....	45
INSTALL RADAR VEHICLE DETECTION SYSTEM	45
MESSENGER CABLE REMOVAL.....	46
TRIPLEX (#6 GAUGE)	46
FOUNDATIONS AND ANCHOR ROD ASSEMBLIES FOR METAL POLES:.....	47
MATERIAL AND EQUIPMENT STORAGE & PARKING OF PERSONAL VEHICLES:	55
WORK ZONE INSTALLER:.....	56
STANDARD SPECIAL PROVISION	57
AVAILABILITY OF FUNDS – TERMINATION OF CONTRACTS	57
ERRATA	58
PLANT AND PEST QUARANTINES	60
TITLE VI AND NONDISCRIMINATION:	61
MINORITY AND FEMALE EMPLOYMENT REQUIREMENTS	68
REQUIRED CONTRACT PROVISIONS FEDERAL - AID CONSTRUCTION	
CONTRACTS.....	71
ON-THE-JOB TRAINING.....	80
MINIMUM WAGES	83
MINIMUM WAGES	88
LISTING OF DBE SUBCONTRACTORS.....	93
ADDENDUM(S)	95
EXECUTION OF BID.....	97
DEBARMENT CERTIFICATION	103
PURCHASE ORDER CONTRACT BID FORM	105

PROPOSAL ITEM SHEET AND SIGNATURE SHEET

INSTRUCTIONS TO BIDDERS

**PLEASE READ ALL INSTRUCTIONS CAREFULLY
BEFORE PREPARING AND SUBMITTING YOUR BID.**

All bids shall be prepared and submitted in accordance with the following requirements. Failure to comply with any requirement may cause the bid to be considered irregular and may be grounds for rejection of the bid.

TRADITIONAL PAPER BIDS:

1. Download the entire proposal from the Connect NCDOT website and return the entire proposal with your bid.
2. If the Interested Parties List provision SP01 G02 is part of the proposal prior to submitting a bid on a project, the bidder shall sign up on the *Interested Parties List* in conformance with Interested Parties List provision SP01 G02.
3. All entries on the itemized proposal sheet (bid form) shall be written in ink or typed.
4. The Bidder shall submit a unit price for every item on the itemized proposal sheet. The unit prices for the various contract items shall be written in figures. Unit prices shall be rounded off by the Bidder to contain no more than FOUR decimal places.
5. An amount bid shall be entered on the itemized proposal sheet for every item. The amount bid for each item shall be determined by multiplying each unit bid by the quantity for that item, and shall be written in figures in the "Amount" column of the form.
6. The total amount bid shall be written in figures in the proper place on the bid form. The total amount bid shall be determined by adding the amounts bid for each item.
7. Changes to any entry shall be made by marking through the entry in ink and making the correct entry adjacent thereto in ink. A representative of the Bidder shall initial the change in ink. Do not use correction fluid, correction tape or similar product to make corrections.
8. The bid shall be properly executed on the included **Execution of Bid – Non-collusion, Debarment and Gift Ban Certification** form. All bids shall show the following information:
 - a. Name of corporation, partnership, Limited Liability Company, joint venture, individual or firm, submitting bid.
Corporations that have a corporate seal should include it on the bid.
 - b. Name of individual or representative submitting bid and position or title held on behalf of the bidder.
 - c. Name, signature, and position or title of witness.
9. The bid shall not contain any unauthorized additions, deletions, or conditional bids.
10. The Bidder shall not add any provision reserving the right to accept or reject an award, or to enter into a contract pursuant to an award.
11. **THE PROPOSAL WITH THE ITEMIZED PROPOSAL SHEET ATTACHED SHALL BE PLACED IN A SEALED ENVELOPE AND SHALL BE DELIVERED TO AND RECEIVED IN THE NCDOT DIVISION OFFICE, LOCATED AT 5501 Barbados Blvd., BY 2:00 PM ON, August 18, 2022.**
12. The sealed bid must display the following statement on the front of the sealed envelope:

**QUOTATION FOR – D3POC0144 ON CALL SIGNAL MAINTENANCE THROUGHOUT DUPLIN,
ONslow, PENDER, SAMPSON, BRUNSWICK & NEW HANOVER COUNTIES TO BE OPENED
AT 2:00 PM ON, August 18, 2022.**

13. If delivered by mail, the sealed envelope shall be placed in another sealed envelope and the outer envelope shall be addressed as follows:

**N. C. DEPARTMENT OF TRANSPORTATION
ATTN: Jonathan W. Mitchell
5501 Barbados Blvd.
Castle Hayne, NC 28429**

PROJECT SPECIAL PROVISIONS**GENERAL****MANDATORY PRE-BID CONFERENCE AND PROPOSAL REVIEW:**

All prospective bidders shall attend a Mandatory Pre-Bid Conference as shown below:

Date: Tuesday, AUGUST 9th, 2022

Time: 10:00 AM

Place: Division Three Operations Building Conference Room

Location: 5501 Barbados Blvd., Castle Hayne, NC 28429

County: New Hanover

Contact for Directions: 910-341-2001

NOTE: The Mandatory Pre-Bid Conference will begin promptly at 10:00 AM. An official clock for the pre-bid conference will be designated. Contractors who are late will not be permitted to sign in or to participate in the conference.

No questions concerning the project will be answered by any Department personnel at any time, except at the Mandatory Pre-Bid Conference.

This conference will be conducted by Department personnel for the purpose of providing additional information about the project and to give bidders an opportunity to ask any questions they may have.

The Engineer will explain areas of responsibility, standards of performance and expected results. This is also intended to be a time for the Contractor to raise questions as to the present condition of the facility. The Contractor is encouraged to make his/her own observations of the site(s) and may choose to have an electrician, plumber or other tradesman to assist him in determining the condition of the items identified in this contract as the Contractor's responsibility. For items that can be shown to the Department to be deficient, the Department may elect to: 1) repair or replace such item to bring it up to standard before the Contractor assumes responsibility, 2) not repair or replace such item, but remove this item from the Contractor's responsibility.

Any changes made to the contract during the pre-bid conference will be documented and included in an addendum. A copy of which to be provided to each qualified bidder. The addendum must be returned with the bid package, signed and dated. Failure to do so will result in disqualification of bid.

MANDATORY PRE-BID CONFERENCE: ELIGIBILITY TO BID

All prospective bidders at the Mandatory Pre-Bid Conference shall meet all of the requirements as shown below:

Only bidders who have attended the entire conference and properly registered at the Mandatory Pre-Bid Conference will be considered eligible to bid on this project. A bid received from a Bidder who has not attended and properly registered at the conference will be rejected as an irregular bid and will not be considered for award.

Attendance at the Mandatory Pre-Bid Conference will not meet the requirements of proper registration unless the individual attending has registered at the conference in accordance with the following:

1. The individual attending the Mandatory Pre-Bid Conference is a full-time employee of the company being represented and has **administrative/supervisory** authority over the work to be performed under this contract.
2. The individual signs his/her name and company title on the official roster.
3. The individual writes in the name and address of the company he or she represents.
4. Only one company is shown as being represented by the individual attending.

CONTRACT TIME FOR ID/IQ:

(2-15-22)

108

SP1 G11

The date of availability for this contract is **September 29, 2022**.

The completion date for this contract is **September 28, 2023**.

Except where otherwise provided by the contract, observation periods required by the contract will not be a part of the work to be completed by the completion date and/or intermediate contract times stated in the contract. The acceptable completion of the observation periods that extend beyond the final completion date shall be a part of the work covered by the performance and payment bonds.

Work shall be accomplished in a continuous manner once the contractor begins.

Any liquidated damages for this contract will be assessed per the Mobilization and Liquidated Damages provision located elsewhere in this Contract.

INTERMEDIATE CONTRACT TIME NUMBER 1 AND LIQUIDATED DAMAGES:

(2-20-07)

108

SP1 G14 A

The Contractor shall complete the required work of installing, maintaining, and removing the traffic control devices for lane closures and restoring traffic to the existing traffic pattern. The Contractor shall not close or narrow a lane of traffic on **ANY ROAD** during the following time restrictions:

DAY AND TIME RESTRICTIONS

MONDAY - FRIDAY 6:00AM - 9:00AM & 4:00PM - 6:00PM

In addition, the Contractor shall not close or narrow a lane of traffic on **ANY ROAD**, detain and/or alter the traffic flow on or during holidays, holiday weekends, special events, or any other time when traffic is unusually heavy, including the following schedules:

HOLIDAY AND HOLIDAY WEEKEND LANE CLOSURE RESTRICTIONS

1. For **unexpected occurrence** that creates unusually high traffic volumes, as directed by the Engineer.
2. For **New Year's Day**, between the hours of **4:00 PM** December 31st and **9:00 AM** January 2nd. If New Year's Day is on a Friday, Saturday, Sunday or Monday, then until **9:00 AM** the following Tuesday.
3. For **Easter**, between the hours of **4:00 PM** Thursday and **9:00 AM** Monday.
4. For **Memorial Day**, between the hours of **4:00 PM** Friday and **9:00 AM** Tuesday.
5. For **Independence Day**, between the hours of **4:00 PM** the day before Independence Day and **9:00 AM** the day after Independence Day.

If **Independence Day** is on a Friday, Saturday, Sunday or Monday, then between the hours of **4:00 PM** the Thursday before Independence Day and **9:00 AM** the Tuesday after Independence Day.
6. For **Labor Day**, between the hours of **4:00 PM** Friday and **9:00 AM** Tuesday.
7. For **Thanksgiving Day**, between the hours of **4:00 PM** Tuesday and **9:00 AM** Monday.
8. For **Christmas**, between the hours of **4:00 PM** the Friday before the week of Christmas Day and **9:00 AM** the following Tuesday after the week of Christmas Day.

Holidays and holiday weekends shall include New Year's, Easter, Memorial Day, Independence Day, Labor Day, Thanksgiving, and Christmas. The Contractor shall schedule his work so that lane closures will not be required during these periods, unless otherwise directed by the Engineer.

The time of availability for this intermediate contract work shall be the time the Contractor begins to install all traffic control devices for lane closures according to the time restrictions listed herein.

The completion time for this intermediate contract work shall be the time the Contractor is required to complete the removal of all traffic control devices for lane closures according to the time restrictions stated above and place traffic in the existing traffic pattern.

The liquidated damages are **Eight Hundred Fifty Dollars (\$ 850.00)** per hour.

NO MAJOR CONTRACT ITEMS:

(2-19-02) (Rev. 8-21-07)

104

SP1 G31

None of the items included in this contract will be major items.

SPECIALTY ITEMS:

(7-1-95)(Rev. 7-20-21)

108-6

SP1 G37

Items listed below will be the specialty items for this contract (see Article 108-6 of the *2018 Standard Specifications*).

Line # 6-79	Description Signals/ITS System
-----------------------	--

FUEL PRICE ADJUSTMENT PAPER BID:

(11-15-05) (Rev. 7-20-21)

109-8

SP1 G43

Revise the *2018 Standard Specifications* as follows:

Page 1-87, Article 109-8, Fuel Price Adjustments, add the following:

The base index price for DIESEL #2 FUEL is **\$ 4.5239** per gallon. Where any of the following are included as pay items in the contract, they will be eligible for fuel price adjustment.

The pay items and the fuel factor used in calculating adjustments to be made will be as follows:

Description	Units	Fuel Usage Factor Diesel
Unclassified Excavation	Gal/CY	0.29
Borrow Excavation	Gal/CY	0.29
Class IV Subgrade Stabilization	Gal/Ton	0.55
Aggregate Base Course	Gal/Ton	0.55
Sub-Ballast	Gal/Ton	0.55
Asphalt Concrete Base Course, Type _____	Gal/Ton	0.90 or 2.90
Asphalt Concrete Intermediate Course, Type _____	Gal/Ton	0.90 or 2.90
Asphalt Concrete Surface Course, Type _____	Gal/Ton	0.90 or 2.90
Open-Graded Asphalt Friction Course	Gal/Ton	0.90 or 2.90
Permeable Asphalt Drainage Course, Type _____	Gal/Ton	0.90 or 2.90
Sand Asphalt Surface Course, Type _____	Gal/Ton	0.90 or 2.90
Aggregate for Cement Treated Base Course	Gal/Ton	0.55
Portland Cement for Cement Treated Base Course	Gal/Ton	0.55
___" Portland Cement Concrete Pavement	Gal/SY	0.245
Concrete Shoulders Adjacent to ___" Pavement	Gal/SY	0.245

For the asphalt items noted in the chart as eligible for fuel adjustments, the bidder may include the *Fuel Usage Factor Adjustment Form for Paper Bid* with their bid submission if they elect to use the fuel usage factor. The *Fuel Usage Factor Adjustment Form for Paper Bid* is included toward the end of this paper bid document when asphalt items noted in the chart as eligible for fuel adjustments are part of the project.

Select either 2.90 Gal/Ton fuel factor or 0.90 Gal/Ton fuel factor for each asphalt line item on the *Fuel Usage Factor Adjustment Form for Paper Bid*. The selected fuel factor for each asphalt item will remain in effect for the duration of the contract.

Failure to complete the *Fuel Usage Factor Adjustment Form for Paper Bid* will result in using 2.90 gallons per ton as the Fuel Usage Factor for Diesel for the asphalt items noted above. The contractor will not be permitted to change the Fuel Usage Factor after the bids are submitted.

SCHEDULE OF ESTIMATED COMPLETION PROGRESS:

(7-15-08) (Rev. 5-13-19)

108-2

SP1 G58

The Contractor's attention is directed to the Standard Special Provision entitled *Availability of Funds Termination of Contracts* included elsewhere in this proposal. The Department of Transportation's schedule of estimated completion progress for this project as required by that Standard Special Provision is as follows:

	<u>Fiscal Year</u>	<u>Progress (% of Dollar Value)</u>
2023	(7/01/22 - 6/30/23)	80% of Total Amount Bid
2024	(7/01/23 - 6/30/24)	20% of Total Amount Bid
2025	(7/01/24 - 6/30/25)	0% of Total Amount Bid
2026	(7/01/25 - 6/30/26)	0% of Total Amount Bid
2027	(7/01/26 - 6/30/27)	0% of Total Amount Bid

The Contractor shall also furnish his own progress schedule in accordance with Article 108-2 of the *2018 Standard Specifications*. Any acceleration of the progress as shown by the Contractor's progress schedule over the progress as shown above shall be subject to the approval of the Engineer.

DISADVANTAGED BUSINESS ENTERPRISE (DIVISIONS):

(10-16-07)(Rev. 8-17-21)

102-15(J)

SP1 G62

Description

The purpose of this Special Provision is to carry out the U.S. Department of Transportation's policy of ensuring nondiscrimination in the award and administration of contracts financed in whole or in part with Federal funds. This provision is guided by 49 CFR Part 26.

Definitions

Additional DBE Subcontractors - Any DBE submitted at the time of bid that will not be used to meet the DBE goal. No submittal of a Letter of Intent is required.

Committed DBE Subcontractor - Any DBE submitted at the time of bid that is being used to meet the DBE goal by submission of a Letter of Intent. Or any DBE used as a replacement for a previously committed DBE firm.

Contract Goal Requirement - The approved DBE participation at time of award, but not greater than the advertised contract goal.

DBE Goal - A portion of the total contract, expressed as a percentage, that is to be performed by committed DBE subcontractor(s).

Disadvantaged Business Enterprise (DBE) - A firm certified as a Disadvantaged Business Enterprise through the North Carolina Unified Certification Program.

Goal Confirmation Letter - Written documentation from the Department to the bidder confirming the Contractor's approved, committed DBE participation along with a listing of the committed DBE firms.

Manufacturer - A firm that operates or maintains a factory or establishment that produces on the premises, the materials or supplies obtained by the Contractor.

Regular Dealer - A firm that owns, operates, or maintains a store, warehouse, or other establishment in which the materials or supplies required for the performance of the contract are bought, kept in stock, and regularly sold to the public in the usual course of business. A regular dealer engages in, as its principal business and in its own name, the purchase and sale or lease of the products in question. A regular dealer in such bulk items as steel, cement, gravel, stone, and petroleum products need not keep such products in stock, if it owns and operates distribution equipment for the products. Brokers and packagers are not regarded as manufacturers or regular dealers within the meaning of this section.

Replacement / Substitution – A full or partial reduction in the amount of work subcontracted to a committed (or an approved substitute) DBE firm.

North Carolina Unified Certification Program (NCUCP) - A program that provides comprehensive services and information to applicants for DBE certification, such that an applicant is required to apply only once for a DBE certification that will be honored by all recipients of USDOT funds in the state and not limited to the Department of Transportation only. The Certification Program is in accordance with 49 CFR Part 26.

United States Department of Transportation (USDOT) - Federal agency responsible for issuing regulations (49 CFR Part 26) and official guidance for the DBE program.

Forms and Websites Referenced in this Provision

DBE Payment Tracking System - On-line system in which the Contractor enters the payments made to DBE subcontractors who have performed work on the project.
<https://apps.dot.state.nc.us/Vendor/PaymentTracking/>

DBE-IS Subcontractor Payment Information - Form for reporting the payments made to all DBE firms working on the project. This form is for paper bid projects only.
<https://connect.ncdot.gov/business/Turnpike/Documents/Form%20DBE-IS%20Subcontractor%20Payment%20Information.pdf>

RF-1 DBE Replacement Request Form - Form for replacing a committed DBE.
<http://connect.ncdot.gov/projects/construction/Construction%20Forms/DBE%20MBE%20WBE%20Replacement%20Request%20Form.pdf>

SAF Subcontract Approval Form - Form required for approval to sublet the contract.
<http://connect.ncdot.gov/projects/construction/Construction%20Forms/Subcontract%20Approval%20Form%20Rev.%202012.zip>

JC-1 Joint Check Notification Form - Form and procedures for joint check notification. The form acts as a written joint check agreement among the parties providing full and prompt disclosure of the expected use of joint checks.

<http://connect.ncdot.gov/projects/construction/Construction%20Forms/Joint%20Check%20Notification%20Form.pdf>

Letter of Intent - Form signed by the Contractor and the DBE subcontractor, manufacturer or regular dealer that affirms that a portion of said contract is going to be performed by the signed DBE for the estimated amount (based on quantities and unit prices) listed at the time of bid.

<http://connect.ncdot.gov/letting/LetCentral/Letter%20of%20Intent%20to%20Perform%20as%20a%20Subcontractor.pdf>

Listing of DBE Subcontractors Form - Form for entering DBE subcontractors on a project that will meet this DBE goal. This form is for paper bids only.

[http://connect.ncdot.gov/municipalities/Bid%20Proposals%20for%20LGA%20Content/08%20DBE%20Subcontractors%20\(Federal\).docx](http://connect.ncdot.gov/municipalities/Bid%20Proposals%20for%20LGA%20Content/08%20DBE%20Subcontractors%20(Federal).docx)

Subcontractor Quote Comparison Sheet - Spreadsheet for showing all subcontractor quotes in the work areas where DBEs quoted on the project. This sheet is submitted with good faith effort packages.

<http://connect.ncdot.gov/business/SmallBusiness/Documents/DBE%20Subcontractor%20Quote%20Comparison%20Example.xls>

DBE Goal

The following DBE goal for participation by Disadvantaged Business Enterprises is established for this contract:

Disadvantaged Business Enterprises **0.0** %

- (A) *If the DBE goal is more than zero*, the Contractor shall exercise all necessary and reasonable steps to ensure that DBEs participate in at least the percent of the contract as set forth above as the DBE goal.
- (B) *If the DBE goal is zero*, the Contractor shall make an effort to recruit and use DBEs during the performance of the contract. Any DBE participation obtained shall be reported to the Department.

Directory of Transportation Firms (Directory)

Real-time information is available about firms doing business with the Department and firms that are certified through NCUCP in the Directory of Transportation Firms. Only firms identified in the Directory as DBE certified shall be used to meet the DBE goal. The Directory can be found at the following link. [https:// www.ebs.nc.gov/VendorDirectory/default.html](https://www.ebs.nc.gov/VendorDirectory/default.html)

The listing of an individual firm in the directory shall not be construed as an endorsement of the firm's capability to perform certain work.

Listing of DBE Subcontractors

At the time of bid, bidders shall submit all DBE participation that they anticipate to use during the life of the contract. Only those identified to meet the DBE goal will be considered committed, even though the listing shall include both committed DBE subcontractors and additional DBE subcontractors. Additional DBE subcontractor participation submitted at the time of bid will be used toward the Department's overall race-neutral goal. Only those firms with current DBE certification at the time of bid opening will be

acceptable for listing in the bidder's submittal of DBE participation. The Contractor shall indicate the following required information:

(A) Electronic Bids

Bidders shall submit a listing of DBE participation in the appropriate section of the electronic submittal file.

- (1) Submit the names and addresses of DBE firms identified to participate in the contract. If the bidder uses the updated listing of DBE firms shown in the electronic submittal file, the bidder may use the dropdown menu to access the name and address of the DBE firm.
- (2) Submit the contract line numbers of work to be performed by each DBE firm. When no figures or firms are entered, the bidder will be considered to have no DBE participation.
- (3) The bidder shall be responsible for ensuring that the DBE is certified at the time of bid by checking the Directory of Transportation Firms. If the firm is not certified at the time of the bid-letting, that DBE's participation will not count towards achieving the DBE goal.

(B) Paper Bids

- (1) *If the DBE goal is more than zero,*
 - (a) Bidders, at the time the bid proposal is submitted, shall submit a listing of DBE participation, including the names and addresses on *Listing of DBE Subcontractors* contained elsewhere in the contract documents in order for the bid to be considered responsive. Bidders shall indicate the total dollar value of the DBE participation for the contract.
 - (b) If bidders have no DBE participation, they shall indicate this on the *Listing of DBE Subcontractors* by entering the word "None" or the number "0." This form shall be completed in its entirety. **Blank forms will not be deemed to represent zero participation.** Bids submitted that do not have DBE participation indicated on the appropriate form will not be read publicly during the opening of bids. The Department will not consider these bids for award and the proposal will be rejected.
 - (c) The bidder shall be responsible for ensuring that the DBE is certified at the time of bid by checking the Directory of Transportation Firms. If the firm is not certified at the time of the bid-letting, that DBE's participation will not count towards achieving the DBE goal.
- (2) *If the DBE goal is zero,* entries on the *Listing of DBE Subcontractors* are not required, however any DBE participation that is achieved during the project shall be reported in accordance with requirements contained elsewhere in the special provision.

DBE Prime Contractor

When a certified DBE firm bids on a contract that contains a DBE goal, the DBE firm is responsible for meeting the goal or making good faith efforts to meet the goal, just like any other bidder. In most cases, a DBE bidder on a contract will meet the DBE goal by virtue of the work it performs on the contract with its

own forces. However, all the work that is performed by the DBE bidder and any other DBE subcontractors will count toward the DBE goal. The DBE bidder shall list itself along with any DBE subcontractors, if any, in order to receive credit toward the DBE goal.

For example, if the DBE goal is 45% and the DBE bidder will only perform 40% of the contract work, the prime will list itself at 40%, and the additional 5% shall be obtained through additional DBE participation with DBE subcontractors or documented through a good faith effort.

DBE prime contractors shall also follow Sections A or B listed under *Listing of DBE Subcontractor* just as a non-DBE bidder would.

Written Documentation – Letter of Intent

The bidder shall submit written documentation for each DBE that will be used to meet the DBE goal of the contract, indicating the bidder's commitment to use the DBE in the contract. This documentation shall be submitted on the Department's form titled *Letter of Intent*.

The documentation shall be received in the office of the Engineer no later than 2:00 p.m. of the fifth calendar day following opening of bids, unless the fifth day falls on Saturday, Sunday or an official state holiday. In that situation, it is due in the office of the Engineer no later than 10:00 a.m. on the next official state business day.

If the bidder fails to submit the Letter of Intent from each committed DBE to be used toward the DBE goal, or if the form is incomplete (i.e. both signatures are not present), the DBE participation will not count toward meeting the DBE goal. If the lack of this participation drops the commitment below the DBE goal, the Contractor shall submit evidence of good faith efforts, completed in its entirety, to the Engineer no later than 2:00 p.m. on the eighth calendar day following opening of bids, unless the eighth day falls on Saturday, Sunday or an official state holiday. In that situation, it is due in the office of the Engineer no later than 10:00 a.m. on the next official state business day.

Submission of Good Faith Effort

If the bidder fails to meet or exceed the DBE goal the apparent lowest responsive bidder shall submit to the Department documentation of adequate good faith efforts made to reach the DBE goal.

One complete set and 5 copies of this information shall be received in the office of the Engineer no later than 2:00 p.m. of the fifth calendar day following opening of bids, unless the fifth day falls on Saturday, Sunday or an official state holiday. In that situation, it is due in the office of the Engineer no later than 10:00 a.m. on the next official state business day.

Note: Where the information submitted includes repetitious solicitation letters, it will be acceptable to submit a representative letter along with a distribution list of the firms that were solicited. Documentation of DBE quotations shall be a part of the good faith effort submittal. This documentation may include written subcontractor quotations, telephone log notations of verbal quotations, or other types of quotation documentation.

Consideration of Good Faith Effort for Projects with DBE Goals More Than Zero

Adequate good faith efforts mean that the bidder took all necessary and reasonable steps to achieve the goal which, by their scope, intensity, and appropriateness, could reasonably be expected to obtain sufficient DBE

participation. Adequate good faith efforts also mean that the bidder actively and aggressively sought DBE participation. Mere *pro forma* efforts are not considered good faith efforts.

The Department will consider the quality, quantity, and intensity of the different kinds of efforts a bidder has made. Listed below are examples of the types of actions a bidder will take in making a good faith effort to meet the goal and are not intended to be exclusive or exhaustive, nor is it intended to be a mandatory checklist.

- (A) Soliciting through all reasonable and available means (e.g. attendance at pre-bid meetings, advertising, written notices, use of verifiable electronic means through the use of the NCDOT Directory of Transportation Firms) the interest of all certified DBEs who have the capability to perform the work of the contract. The bidder must solicit this interest within at least 10 days prior to bid opening to allow the DBEs to respond to the solicitation. Solicitation shall provide the opportunity to DBEs within the Division and surrounding Divisions where the project is located. The bidder must determine with certainty if the DBEs are interested by taking appropriate steps to follow up initial solicitations.
- (B) Selecting portions of the work to be performed by DBEs in order to increase the likelihood that the DBE goals will be achieved.
 - (1) Where appropriate, break out contract work items into economically feasible units to facilitate DBE participation, even when the prime contractor might otherwise prefer to perform these work items with its own forces.
 - (2) Negotiate with subcontractors to assume part of the responsibility to meet the contract DBE goal when the work to be sublet includes potential for DBE participation (2nd and 3rd tier subcontractors).
- (C) Providing interested DBEs with adequate information about the plans, specifications, and requirements of the contract in a timely manner to assist them in responding to a solicitation.
- (D)
 - (1) Negotiating in good faith with interested DBEs. It is the bidder's responsibility to make a portion of the work available to DBE subcontractors and suppliers and to select those portions of the work or material needs consistent with the available DBE subcontractors and suppliers, so as to facilitate DBE participation. Evidence of such negotiation includes the names, addresses, and telephone numbers of DBEs that were considered; a description of the information provided regarding the plans and specifications for the work selected for subcontracting; and evidence as to why additional agreements could not be reached for DBEs to perform the work.
 - (2) A bidder using good business judgment would consider a number of factors in negotiating with subcontractors, including DBE subcontractors, and would take a firm's price and capabilities as well as contract goals into consideration. However, the fact that there may be some additional costs involved in finding and using DBEs is not in itself sufficient reason for a bidder's failure to meet the contract DBE goal, as long as such costs are reasonable. Also, the ability or desire of a prime contractor to perform the work of a contract with its own organization does not relieve the bidder of the responsibility to make good faith efforts. Bidding contractors are not, however, required to accept higher quotes from DBEs if the price difference is excessive or unreasonable.

- (E) Not rejecting DBEs as being unqualified without sound reasons based on a thorough investigation of their capabilities. The bidder's standing within its industry, membership in specific groups, organizations, or associates and political or social affiliations (for example, union vs. non-union employee status) are not legitimate causes for the rejection or non-solicitation of bids in the bidder's efforts to meet the project goal.
- (F) Making efforts to assist interested DBEs in obtaining bonding, lines of credit, or insurance as required by the recipient or bidder.
- (G) Making efforts to assist interested DBEs in obtaining necessary equipment, supplies, materials, or related assistance or services.
- (H) Effectively using the services of available minority/women community organizations; minority/women contractors' groups; Federal, State, and local minority/women business assistance offices; and other organizations as allowed on a case-by-case basis to provide assistance in the recruitment and placement of DBEs. Contact within 7 days from the bid opening the Business Opportunity and Work Force Development Unit at BOWD@ncdot.gov to give notification of the bidder's inability to get DBE quotes.
- (I) Any other evidence that the bidder submits which shows that the bidder has made reasonable good faith efforts to meet the DBE goal.

In addition, the Department may take into account the following:

- (1) Whether the bidder's documentation reflects a clear and realistic plan for achieving the DBE goal.
- (2) The bidders' past performance in meeting the DBE goals.
- (3) The performance of other bidders in meeting the DBE goal. For example, when the apparent successful bidder fails to meet the DBE goal, but others meet it, you may reasonably raise the question of whether, with additional reasonable efforts the apparent successful bidder could have met the goal. If the apparent successful bidder fails to meet the DBE goal, but meets or exceeds the average DBE participation obtained by other bidders, the Department may view this, in conjunction with other factors, as evidence of the apparent successful bidder having made a good faith effort.

If the Department does not award the contract to the apparent lowest responsive bidder, the Department reserves the right to award the contract to the next lowest responsive bidder that can satisfy to the Department that the DBE goal can be met or that an adequate good faith effort has been made to meet the DBE goal.

Non-Good Faith Appeal

The Engineer will notify the contractor verbally and in writing of non-good faith. A contractor may appeal a determination of non-good faith made by the Goal Compliance Committee. If a contractor wishes to appeal the determination made by the Committee, they shall provide written notification to the Engineer. The appeal shall be made within 2 business days of notification of the determination of non-good faith.

Counting DBE Participation Toward Meeting DBE Goal

(A) Participation

The total dollar value of the participation by a committed DBE will be counted toward the contract goal requirement. The total dollar value of participation by a committed DBE will be based upon the value of work actually performed by the DBE and the actual payments to DBE firms by the Contractor.

(B) Joint Checks

Prior notification of joint check use shall be required when counting DBE participation for services or purchases that involves the use of a joint check. Notification shall be through submission of Form JC-1 (*Joint Check Notification Form*) and the use of joint checks shall be in accordance with the Department's Joint Check Procedures.

(C) Subcontracts (Non-Trucking)

A DBE may enter into subcontracts. Work that a DBE subcontracts to another DBE firm may be counted toward the contract goal requirement. Work that a DBE subcontracts to a non-DBE firm does not count toward the contract goal requirement. If a DBE contractor or subcontractor subcontracts a significantly greater portion of the work of the contract than would be expected on the basis of standard industry practices, it shall be presumed that the DBE is not performing a commercially useful function. The DBE may present evidence to rebut this presumption to the Department. The Department's decision on the rebuttal of this presumption is subject to review by the Federal Highway Administration but is not administratively appealable to USDOT.

(D) Joint Venture

When a DBE performs as a participant in a joint venture, the Contractor may count toward its contract goal requirement a portion of the total value of participation with the DBE in the joint venture, that portion of the total dollar value being a distinct clearly defined portion of work that the DBE performs with its forces.

(E) Suppliers

A contractor may count toward its DBE requirement 60 percent of its expenditures for materials and supplies required to complete the contract and obtained from a DBE regular dealer and 100 percent of such expenditures from a DBE manufacturer.

(F) Manufacturers and Regular Dealers

A contractor may count toward its DBE requirement the following expenditures to DBE firms that are not manufacturers or regular dealers:

- (1) The fees or commissions charged by a DBE firm for providing a *bona fide* service, such as professional, technical, consultant, or managerial services, or for providing bonds or insurance specifically required for the performance of a DOT-assisted contract, provided the fees or commissions are determined to be reasonable and not excessive as compared with fees and commissions customarily allowed for similar services.

- (2) With respect to materials or supplies purchased from a DBE, which is neither a manufacturer nor a regular dealer, count the entire amount of fees or commissions charged for assistance in the procurement of the materials and supplies, or fees or transportation charges for the delivery of materials or supplies required on a job site (but not the cost of the materials and supplies themselves), provided the fees are determined to be reasonable and not excessive as compared with fees customarily allowed for similar services.

Commercially Useful Function

(A) DBE Utilization

The Contractor may count toward its contract goal requirement only expenditures to DBEs that perform a commercially useful function in the work of a contract. A DBE performs a commercially useful function when it is responsible for execution of the work of the contract and is carrying out its responsibilities by actually performing, managing, and supervising the work involved. To perform a commercially useful function, the DBE shall also be responsible with respect to materials and supplies used on the contract, for negotiating price, determining quality and quantity, ordering the material and installing (where applicable) and paying for the material itself. To determine whether a DBE is performing a commercially useful function, the Department will evaluate the amount of work subcontracted, industry practices, whether the amount the firm is to be paid under the contract is commensurate with the work it is actually performing and the DBE credit claimed for its performance of the work, and any other relevant factors.

(B) DBE Utilization in Trucking

The following factors will be used to determine if a DBE trucking firm is performing a commercially useful function:

- (1) The DBE shall be responsible for the management and supervision of the entire trucking operation for which it is responsible on a particular contract, and there shall not be a contrived arrangement for the purpose of meeting DBE goals.
- (2) The DBE shall itself own and operate at least one fully licensed, insured, and operational truck used on the contract.
- (3) The DBE receives credit for the total value of the transportation services it provides on the contract using trucks it owns, insures, and operates using drivers it employs.
- (4) The DBE may subcontract the work to another DBE firm, including an owner-operator who is certified as a DBE. The DBE who subcontracts work to another DBE receives credit for the total value of the transportation services the subcontracted DBE provides on the contract.
- (5) The DBE may also subcontract the work to a non-DBE firm, including from an owner-operator. The DBE who subcontracts the work to a non-DBE is entitled to credit for the total value of transportation services provided by the non-DBE subcontractor not to exceed the value of transportation services provided by DBE-owned trucks on the contract. Additional participation by non-DBE subcontractors receives credit only for the fee or commission it receives as

a result of the subcontract arrangement. The value of services performed under subcontract agreements between the DBE and the Contractor will not count towards the DBE contract requirement.

- (6) A DBE may lease truck(s) from an established equipment leasing business open to the general public. The lease must indicate that the DBE has exclusive use of and control over the truck. This requirement does not preclude the leased truck from working for others during the term of the lease with the consent of the DBE, so long as the lease gives the DBE absolute priority for use of the leased truck. This type of lease may count toward the DBE's credit as long as the driver is under the DBE's payroll.
- (7) Subcontracted/leased trucks shall display clearly on the dashboard the name of the DBE that they are subcontracted/leased to and their own company name if it is not identified on the truck itself. Magnetic door signs are not permitted.

DBE Replacement

When a Contractor has relied on a commitment to a DBE subcontractor (or an approved substitute DBE subcontractor) to meet all or part of a contract goal requirement, the contractor shall not terminate the DBE subcontractor for convenience. This includes, but is not limited to, instances in which the Contractor seeks to perform the work of the terminated subcontractor with another DBE subcontractor, a non-DBE subcontractor, or with the Contractor's own forces or those of an affiliate.

The Contractor must give notice in writing both by certified mail and email to the DBE subcontractor, with a copy to the Engineer of its intent to request to terminate and/or substitute, and the reason for the request. The Contractor must give the DBE subcontractor five (5) business days to respond to the Contractor's Notice of Intent to Request Termination and/or Substitution. If the DBE subcontractor objects to the intended termination/substitution, the DBE, within five (5) business days must advise the Contractor and the Department of the reasons why the action should not be approved. The five-day notice period shall begin on the next business day after written notice is provided to the DBE subcontractor.

A committed DBE subcontractor may only be terminated after receiving the Department's written approval based upon a finding of good cause for the proposed termination and/or substitution. For purposes of this section, good cause shall include the following circumstances:

- (a) The listed DBE subcontractor fails or refuses to execute a written contract;
- (b) The listed DBE subcontractor fails or refuses to perform the work of its subcontract in a way consistent with normal industry standards. Provided, however, that good cause does not exist if the failure or refusal of the DBE subcontractor to perform its work on the subcontract results from the bad faith or discriminatory action of the prime contractor;
- (c) The listed DBE subcontractor fails or refuses to meet the prime contractor's reasonable, nondiscriminatory bond requirements;
- (d) The listed DBE subcontractor becomes bankrupt, insolvent, or exhibits credit unworthiness;
- (e) The listed DBE subcontractor is ineligible to work on public works projects because of suspension and debarment proceedings pursuant to 2 CFR Parts 180, 215 and 1,200 or applicable state law;
- (f) The listed DBE subcontractor is not a responsible contractor;

- (g) The listed DBE voluntarily withdraws from the project and provides written notice of withdrawal;
- (h) The listed DBE is ineligible to receive DBE credit for the type of work required;
- (i) A DBE owner dies or becomes disabled with the result that the listed DBE contractor is unable to complete its work on the contract;
- (j) Other documented good cause that compels the termination of the DBE subcontractor. Provided, that good cause does not exist if the prime contractor seeks to terminate a DBE it relied upon to obtain the contract so that the prime contractor can self-perform the work for which the DBE contractor was engaged or so that the prime contractor can substitute another DBE or non-DBE contractor after contract award.

The Contractor shall comply with the following for replacement of a committed DBE:

(A) Performance Related Replacement

When a committed DBE is terminated for good cause as stated above, an additional DBE that was submitted at the time of bid may be used to fulfill the DBE commitment. A good faith effort will only be required for removing a committed DBE if there were no additional DBEs submitted at the time of bid to cover the same amount of work as the DBE that was terminated.

If a replacement DBE is not found that can perform at least the same amount of work as the terminated DBE, the Contractor shall submit a good faith effort documenting the steps taken. Such documentation shall include, but not be limited to, the following:

- (1) Copies of written notification to DBEs that their interest is solicited in contracting the work defaulted by the previous DBE or in subcontracting other items of work in the contract.
- (2) Efforts to negotiate with DBEs for specific subbids including, at a minimum:
 - (a) The names, addresses, and telephone numbers of DBEs who were contacted.
 - (b) A description of the information provided to DBEs regarding the plans and specifications for portions of the work to be performed.
- (3) A list of reasons why DBE quotes were not accepted.
- (4) Efforts made to assist the DBEs contacted, if needed, in obtaining bonding or insurance required by the Contractor.

(B) Decertification Replacement

- (1) When a committed DBE is decertified by the Department after the SAF (*Subcontract Approval Form*) has been received by the Department, the Department will not require the Contractor to solicit replacement DBE participation equal to the remaining work to be performed by the decertified firm. The participation equal to the remaining work performed by the decertified firm will count toward the contract goal requirement.
- (2) When a committed DBE is decertified prior to the Department receiving the SAF (*Subcontract Approval Form*) for the named DBE firm, the Contractor shall take all necessary and reasonable steps to replace the DBE subcontractor with another DBE subcontractor to perform at least the same amount of work to meet the DBE goal

requirement. If a DBE firm is not found to do the same amount of work, a good faith effort must be submitted to NCDOT (see A herein for required documentation).

- (3) Exception: If the DBE's ineligibility is caused solely by its having exceeded the size standard during the performance of the contract, the Department will not require the Contractor to solicit replacement DBE participation equal to the remaining work to be performed by the decertified firm. The participation equal to the remaining work performed by the decertified firm will count toward the contract goal requirement and overall goal.

All requests for replacement of a committed DBE firm shall be submitted to the Engineer for approval on Form RF-1 (*DBE Replacement Request*). If the Contractor fails to follow this procedure, the Contractor may be disqualified from further bidding for a period of up to 6 months

Changes in the Work

When the Engineer makes changes that result in the reduction or elimination of work to be performed by a committed DBE, the Contractor will not be required to seek additional participation. When the Engineer makes changes that result in additional work to be performed by a DBE based upon the Contractor's commitment, the DBE shall participate in additional work to the same extent as the DBE participated in the original contract work.

When the Engineer makes changes that result in extra work, which has more than a minimal impact on the contract amount, the Contractor shall seek additional participation by DBEs unless otherwise approved by the Engineer.

When the Engineer makes changes that result in an alteration of plans or details of construction, and a portion or all of the work had been expected to be performed by a committed DBE, the Contractor shall seek participation by DBEs unless otherwise approved by the Engineer.

When the Contractor requests changes in the work that result in the reduction or elimination of work that the Contractor committed to be performed by a DBE, the Contractor shall seek additional participation by DBEs equal to the reduced DBE participation caused by the changes.

Reports and Documentation

A SAF (*Subcontract Approval Form*) shall be submitted for all work which is to be performed by a DBE subcontractor. The Department reserves the right to require copies of actual subcontract agreements involving DBE subcontractors.

When using transportation services to meet the contract commitment, the Contractor shall submit a proposed trucking plan in addition to the SAF. The plan shall be submitted prior to beginning construction on the project. The plan shall include the names of all trucking firms proposed for use, their certification type(s), the number of trucks owned by the firm, as well as the individual truck identification numbers, and the line item(s) being performed.

Within 30 calendar days of entering into an agreement with a DBE for materials, supplies or services, not otherwise documented by the SAF as specified above, the Contractor shall furnish the Engineer a copy of the agreement. The documentation shall also indicate the percentage (60% or 100%) of expenditures claimed for DBE credit.

Reporting Disadvantaged Business Enterprise Participation

The Contractor shall provide the Engineer with an accounting of payments made to all DBE firms, including material suppliers and contractors at all levels (prime, subcontractor, or second tier subcontractor). This accounting shall be furnished to the Engineer for any given month by the end of the following month. Failure to submit this information accordingly may result in the following action:

- (A) Withholding of money due in the next partial pay estimate; or
- (B) Removal of an approved contractor from the prequalified bidders' list or the removal of other entities from the approved subcontractors list.

While each contractor (prime, subcontractor, 2nd tier subcontractor) is responsible for accurate accounting of payments to DBEs, it shall be the prime contractor's responsibility to report all monthly and final payment information in the correct reporting manner.

Failure on the part of the Contractor to submit the required information in the time frame specified may result in the disqualification of that contractor and any affiliate companies from further bidding until the required information is submitted.

Failure on the part of any subcontractor to submit the required information in the time frame specified may result in the disqualification of that contractor and any affiliate companies from being approved for work on future projects until the required information is submitted.

Contractors reporting transportation services provided by non-DBE lessees shall evaluate the value of services provided during the month of the reporting period only.

At any time, the Engineer can request written verification of subcontractor payments.

The Contractor shall report the accounting of payments through the Department's DBE Payment Tracking System.

Failure to Meet Contract Requirements

Failure to meet contract requirements in accordance with Subarticle 102-15(J) of the *2018 Standard Specifications* may be cause to disqualify the Contractor.

MULTI-YEAR MAINTENANCE CONTRACTS (ID/IQ):

(4-20-21) (Rev. 4-19-22)

SP1 G75

This contract is a multi-year maintenance contract let pursuant to the provisions of N.C. General Statute §136-28.1(b). No minimum quantity of services is guaranteed to be awarded bidders under this contract. In accordance with N.C. General Statute §136-28.1(b), an award in a maintenance contract may be for an amount less but shall not exceed \$5,000,000 per year. No payments in excess of this amount will be disbursed, in accordance with the Statute.

CERTIFICATION FOR FEDERAL-AID CONTRACTS:

(3-21-90)

SP1 G85

The prospective participant certifies, by signing and submitting this bid or proposal, to the best of his or her knowledge and belief, that:

- (A) No Federal appropriated funds have been paid or will be paid, by or on behalf of the undersigned, to any person for influencing or attempting to influence an officer or employee of any Federal agency, a Member of Congress, an officer or employee of Congress, or an employee of a Member of Congress in connection with the awarding of any Federal contract, the making of any Federal grant, the making of any Federal loan, the entering into of any cooperative agreement, and the extension, continuation, renewal, amendment, or modification of any Federal contract, grant, loan, or cooperative agreement.
- (B) If any funds other than Federal appropriated funds have been paid or will be paid to any person for influencing or attempting to influence an officer or employee of any Federal agency, a Member of Congress, an officer or employee of Congress, or an employee of a Member of Congress in connection with this Federal contract, grant, loan, or cooperative agreement, the undersigned shall complete and submit Standard Form-LLL, *Disclosure Form to Report Lobbying*, in accordance with its instructions.

This certification is a material representation of fact upon which reliance was placed when this transaction was made or entered into. Submission of this certification is a prerequisite for making or entering into this transaction imposed by *Section 1352, Title 31, U.S. Code*. Any person who fails to file the required certification shall be subject to a civil penalty of not less than \$10,000 and not more than \$100,000 for each such failure.

The prospective participant also agrees by submitting his or her bid or proposal that he or she shall require that the language of this certification be included in all lower tier subcontracts, which exceed \$100,000 and that all such subrecipients shall certify and disclose accordingly.

CONTRACTOR'S LICENSE REQUIREMENTS:

(7-1-95)

102-14

SP1 G88

If the successful bidder does not hold the proper license to perform any plumbing, heating, air conditioning, or electrical work in this contract, he will be required to sublet such work to a contractor properly licensed in accordance with *Article 2 of Chapter 87 of the General Statutes* (licensing of heating, plumbing, and air conditioning contractors) and *Article 4 of Chapter 87 of the General Statutes* (licensing of electrical contractors).

RESTRICTIONS ON ITS EQUIPMENT AND SERVICES:

(11-17-20)

SP01 G090

All telecommunications, video or other ITS equipment or services installed or utilized on this project must be in conformance with UNIFORM ADMINISTRATIVE REQUIREMENTS, COST PRINCIPLES, AND AUDIT REQUIREMENTS FOR FEDERAL AWARDS **2 CFR, § 200.216** **Prohibition on certain telecommunications and video surveillance services or equipment.**

USE OF UNMANNED AIRCRAFT SYSTEM (UAS):

(8-20-19)

SP1 G092

The Contractor shall adhere to all Federal, State and Local regulations and guidelines for the use of Unmanned Aircraft Systems (UAS). This includes but is not limited to US 14 CFR Part 107 *Small UAS Rule*, NC GS 15A-300.2 *Regulation of launch and recovery sites*, NC GS 63-95 *Training required for the operation of unmanned aircraft systems*, NC GS 63-96 *Permit required for commercial operation of unmanned aircraft system*, and NCDOT UAS Policy. The required operator certifications include possessing a current Federal Aviation Administration (FAA) Remote Pilot Certificate, a NC UAS Operator Permit as well as operating a UAS registered with the FAA.

Prior to beginning operations, the Contractor shall complete the NCDOT UAS – Flight Operation Approval Form and submit it to the Engineer for approval. All UAS operations shall be approved by the Engineer prior to beginning the operations.

All contractors or subcontractors operating UAS shall have UAS specific general liability insurance to cover all operations under this contract.

The use of UAS is at the Contractor's discretion. No measurement or payment will be made for the use of UAS. In the event that the Department directs the Contractor to utilize UAS, payment will be in accordance with Article 104-7 Extra Work.

EQUIPMENT IDLING GUIDELINES:

(1-19-21)

107

SP1 G096

Exercise reduced fuel consumption and reduced equipment emissions during the construction of all work associated with this contract. Employees engaged in the construction of this project should turn off vehicles when stopped for more than thirty (30) minutes and off-highway equipment should idle no longer than fifteen (15) consecutive minutes.

These guidelines for turning off vehicles and equipment when idling do not apply to:

1. Idling when queuing.
2. Idling to verify the vehicle is in safe operating condition.
3. Idling for testing, servicing, repairing or diagnostic purposes.
4. Idling necessary to accomplish work for which the vehicle was designed (such as operating a crane, mixing concrete, etc.).
5. Idling required to bring the machine system to operating temperature.
6. Emergency vehicles, utility company, construction, and maintenance vehicles where the engines must run to perform needed work.
7. Idling to ensure safe operation of the vehicle.
8. Idling when the propulsion engine is providing auxiliary power for other than heating or air conditioning. (such as hydraulic systems for pavers)
9. When specific traffic, safety, or emergency situations arise.
10. If the ambient temperature is less than 32 degrees Fahrenheit. Limited idling to provide for the safety of vehicle occupants (e.g. to run the heater).
11. If the ambient temperature is greater than 90 degrees Fahrenheit. Limited idling to provide for the safety of vehicle occupants of off-highway equipment (e.g. to run the air conditioning) no more than 30 minutes.

12. Diesel powered vehicles may idle for up to 30 minutes to minimize restart problems. Any vehicle, truck, or equipment in which the primary source of fuel is natural gas or electricity is exempt from the idling limitations set forth in this special provision.

U.S. DEPARTMENT OF TRANSPORTATION HOTLINE:

(11-22-94)

108-5

SP1 G100

To report bid rigging activities call: **1-800-424-9071**

The U.S. Department of Transportation (DOT) operates the above toll-free hotline Monday through Friday, 8:00 a.m. to 5:00 p.m. eastern time. Anyone with knowledge of possible bid rigging, bidder collusion, or other fraudulent activities should use the hotline to report such activities.

The hotline is part of the DOT's continuing effort to identify and investigate highway construction contract fraud and abuse is operated under the direction of the DOT Inspector General. All information will be treated confidentially and caller anonymity will be respected.

CARGO PREFERENCE ACT:

(2-16-16)

Privately owned United States-flag commercial vessels transporting cargoes are subject to the Cargo Preference Act (CPA) of 1954 requirements and regulations found in 46 CFR 381.7. Contractors are directed to clause (b) of 46 CFR 381.7 as follows:

(b) Contractor and Subcontractor Clauses. "Use of United States-flag vessels: The contractor agrees-

" (1) To utilize privately owned United States-flag commercial vessels to ship at least 50 percent of the gross tonnage (computed separately for dry bulk carriers, dry cargo liners, and tankers) involved, whenever shipping any equipment, material, or commodities pursuant to this contract, to the extent such vessels are available at fair and reasonable rates for United States-flag commercial vessels.

(2) To furnish within 20 days following the date of loading for shipments originating within the United States or within 30 working days following the date of loading for shipments originating outside the United States a legible copy of a rated, 'on-board' commercial ocean bill-of-lading in English for each shipment of cargo described in paragraph (b) (1) of this section to both the Contracting Officer (through the prime contractor in the case of subcontractor bills-of-lading) and to the Division of National Cargo, Office of Market Development, Maritime Administration, Washington, DC 20590.

(3) To insert the substance of the provisions of this clause in all subcontracts issued pursuant to this contract."

AWARD LIMITS:

(4-19-22)

103

SP1 G141

Revise the *2018 Standard Specifications* as follows:

Page 1-29, Subarticle 103-4(C), Award Limits, line 4-8, delete and replace the first sentence in the first paragraph with the following:

A bidder who desires to bid on more than one project on which bids are to be opened in the same letting and who desires to avoid receiving an award of more projects than he is equipped to handle, may bid on any number of projects but may limit the total amount of work awarded to him on selected projects by completing the form Award Limits on Multiple Projects for each project subject to the award limit.

WORK ORDER ASSIGNMENT (SINGLE AWARDS) FOR ID/IQ:

(2-15-22)(Rev. 4-19-22)

SPD 01-800A

Work orders will be assigned by the Engineer. The Contractor shall respond to the work order assignments with the anticipated start date, within three working days of notification unless noted otherwise. Failure to complete work in accordance with contract provisions and completion date may result in liquidated damages.

For federal ID/IQ contracts, all work orders will be assigned via the Work Order Assignment Form (Form IDIQ-1SA), and the Contractor is required to formally respond in writing for federal work orders within three working days, unless noted otherwise. The Work Order Assignment Form will also be used for any state ID/IQ contract in which the estimated work order cost meets the threshold for Performance and Payment Bonds in accordance with the Bonding Requirements for ID/IQ provision found elsewhere in this contract. For state ID/IQ contracts in which the work order assignment doesn't meet the threshold for bonds, the Department has the option to use the Work Order Assignment Form or other methods for work order assignments as agreed upon by the Engineer and Contractor.

The Contractor shall be required to prosecute the work in a continuous and uninterrupted manner from the time they begin the work until completion and final acceptance of the work order. Multiple failures of the Contractor to mobilize and begin work on the work order within the agreed upon time frame or failure to complete the work within the given time frame may result in the Contractor being excluded from future work on this contract in accordance with the *Standard Specifications*.

BONDING REQUIREMENTS FOR ID/IQ:

(2-15-22)

SPD 01-810

For purposes of this ID/IQ contract, the following definitions apply:

Project Agreement: A transportation improvement with a defined scope of work; a written agreement between NCDOT and the Federal Government defining the extent of construction work to be undertaken in accordance with the submitted plans, specifications and estimates. Execution of the agreement prompts the authorization to proceed (construction funding).

Project: An undertaking issued to a contractor through a Work Order Assignment. The construction under a Project Agreement may be accomplished by one or more work order assignments, from one or more ID/IQ contracts. Note that for ID/IQ contracts this definition supersedes the definition in the *Standard Specifications*.

Award: The issuance of a signed Work Order Assignment by NCDOT shall constitute the notice of award of a project.

In accordance with North Carolina General Statute 44A-26, bonds are required on contracts awarded for any one project that exceeds \$500,000. Beyond statutory requirements, NCDOT policy requires payment and performance bonds on all projects where the engineer's estimate is \$450,000 or greater, all Asphalt Surface Treatment projects, and projects containing the 12-month guarantee provision. The limit for waiving bonds for all bridge replacement and major bridge rehabilitation projects (latex overlays, etc.) is \$300,000 based on the engineer's estimate. The decision of bonding of a work order assignment below the dollar amounts listed shall be at the discretion of the Division's evaluation of the risks associated with the project.

The need for contract payment and performance bonds will be determined at the Work Order Assignment level. The Work Order Assignment will notify the Contractor of an award of a project and if required, to provide contract payment and performance bonds per Article 103-7 of the *Standard Specifications*. The Work Order Assignment replaces the Notification of Award Letter mentioned in Article 103-4(A) of the *Standard Specifications*.

MOBILIZATION AND LIQUIDATED DAMAGES FOR ID/IQ:

(2-15-22)

SPD 01-820

The Contractor shall mobilize to each location he is required to perform work. There will be no direct pay for Mobilization as it will be incidental to the other bid items. The only exception is if there is an Emergency Mobilization provision within the contract.

The Contractor will be provided a Work Order Assignment for each project with location(s), estimated quantities, and liquidated damages unless waived by the Engineer. Notification will be verbal followed by a faxed or emailed signed Work Order Assignment. There will be no minimum quantities for any line item associated with a particular mobilization. The Contractor shall complete the work identified on each Work Order Assignment.

The Contractor shall mobilize and complete the work within the time specified on the Work Order Assignment. Failure to complete the work by the completion date may result in the application of liquidated damages. Liquidated damage amounts will be based on the work order estimate and the liquidated damage table below.

Work Order Value	Liquidated Damages (per calendar day)
\$0 - \$100K	\$100.00
\$100K - \$200K	\$250.00
\$200K - \$300K	\$500.00
\$300K - \$500K	\$600.00
\$500K - \$1M	\$700.00
\$1M - \$2M	\$850.00

EMERGENCY MOBILIZATION FOR ID/IQ:

(2-15-22)

SPD 01-830

The Contractor shall arrive on site within **4** hours of notification. Compensation will be in addition to the specific line items in the contract. *Emergency Mobilization* will be paid for at the contract unit price per each. Failure to respond within the time frame will result in nonpayment of this item.

Payment will be made under:

Pay Item
Emergency Mobilization

Pay Unit
Each

RENEWAL OF CONTRACT (CPI PRICE ADJUSTMENT) FOR ID/IQ:

(2-15-22)

SPD 01-840

The Contractor shall submit a bid for one year. At the option of the Department, this contract may be extended for 2 additional periods of one year each (maximum (3) three years total). Each year shall have a limit of **\$5,000,000.00 Dollars**.

The compensation payable to the contractor shall be fixed for the first twelve months of this contract. However, upon an application of renewal of the contract, or thirty days prior to the end of each contract period, the renewal contract may be adjusted to reflect the adjustment in the Consumer Price Index for the previous twelve-month period as published by the US Bureau of Labor and Statistics at <http://www.bls.gov/cpi> to be applied to new work order assignments. The Consumer Price Index for All Urban Consumers (CPI-U), US City Average, All Items, 1982-84=100, not seasonally adjusted will be used. If the amount of the requested adjustment is more than ten percent, the Department of Transportation reserves the right to cancel this contract.

The CPI will be determined from a 12-month period. Example below:

<u>Year</u>	<u>J</u>	<u>F</u>	<u>M</u>	<u>A</u>	<u>M</u>	<u>J</u>	<u>J</u>	<u>A</u>	<u>S</u>	<u>O</u>	<u>N</u>	<u>D</u>
2019	251.7	252.8	254.2	255.5	256.1	256.1	256.6	256.6	256.8	257.3	257.2	257.0
2020	258.0	258.7	258.1	256.4	256.4	257.8	259.1	259.9	260.3	260.4	260.2	260.5
2021	261.6	263.0	264.9	267.1	269.2	271.7	273.0	273.6	274.3	276.6	277.9	278.8
2022	281.1											

CPI for current period (July 2021) 273.0
 Less CPI for previous period (July 2020)
 259.1 Equals index point change 13.9
 Divided by previous period CPI 259.1
 Equals 0.0536
Result multiplied by 100 i.e. 0.0536 x 100
 Equals percent change 5.36%

This price escalation method will not be applied to items of work that are separately covered under commodity price escalation clauses. No other changes in the terms, conditions, etc. of this contract will be made when an extension to the contract is implemented. The Engineer will notify the Contractor in writing by **August 1** if the contract may be extended. The Contractor must notify the Engineer in writing by **August 15** of his acceptance or rejection of this offer. Failure on the part of the Contractor to reply will be received as a rejection of contract extension.

DISPUTE RESOLUTION PROCESS FOR ID/IQ:

(2-15-22)

SPD 01-850

If a question should arise on the contract or assignment of a work order, the contractor should notify the Engineer noted on the assignment documentation or the Division Engineer within 48 hours after the scheduled time of bid opening or work order assignment. The following should be included in the notification if applicable:

- the contract for which bids were solicited;
- the particular law, regulation, or contract specification violated;
- a detailed description of the alleged violation; and
- any other information deemed to be relevant.

Once the initial evaluation has been completed, the contractor may be asked to attend a meeting for further discussion and clarification.

Once a determination has been made, the contractor will be notified of the decision by the Division Engineer. If the decision does not meet the satisfaction of the contractor, they have 24 hours from the Division Engineer's notification to elevate the dispute to the Chief Engineer. The Chief Engineer will make the final decision and will not be subject to further review by NCDOT.

PROJECT SPECIAL PROVISIONS

ROADWAY

NOTES TO CONTRACTOR:

The contractor shall not close more than one lane of traffic without prior approval of the Engineer. Portable "Road Construction Ahead" signs may be used in lieu of post mounted signs, as directed by the Engineer.

The contractor needs to pay special attention to the first sentence listed after the table in section 2.10 Description under Special Provision 2.0 Light Standard Light Emitting Diode (LED) Luminaire.

Line items 48 - Metal Strain Signal Pole, 49 - Metal Pole with Single Arm, and 50 - Metal Pole with Double Arm on the Purchase Order Bid Form Special Provisions' are shown under the Signal and Intelligent Transportation Systems Project Special Provisions (version 18.2) listed in the contract. However, these poles and related hardware will be provided by the NCDOT not the contractor.

The Signals and Intelligent Transportation Systems Project Special Provisions (version 18.2), Section 12.9 "Measurement & Payment" is amended to say:

Actual number of metal strain signal poles (without regard to height or load capacity) installed and accepted.

Actual number of metal poles with single mast arms installed and accepted.

Actual number of metal poles with dual mast arms installed and accepted.

The Standard Specifications, Section 1705-1 "Description" is amended to say, "Division 3 Traffic Services will supply vehicle and pedestrian LED signal heads, visors, interconnecting brackets, wire entrance fittings, mounting assemblies, pedestrian push buttons, pedestrian signal signs, and all necessary hardware. The contractor will be responsible for signal cable, lashing wire, grounding systems, and all installation of previously mentioned material."

The Standard Specifications, Section 1706-1 "Description" is amended to say, "Division 3 Traffic Services will supply backing plates for vehicle signal heads with all necessary hardware."

The Standard Specifications, Section 1743-1 "Description" is amended to say, "Division 3 Traffic Services will supply signal pedestal assemblies and all necessary hardware. The contractor will be responsible for foundations, grounding systems, and all installation of previous mentioned material."

The Standard Specifications, Section 1745-1 "Description" is amended to say, "Division 3 Traffic Services will supply signs for signals. The contractor will be responsible for installing NCDOT supplied signs, furnishing cable hangers, rigid sign mounting brackets, U-channel posts, and all necessary hardware.

The Standard Specifications, Section 1751-1 "Description" is amended to say, "Division 3 Traffic Services will supply all flasher cabinets, 2070 cabinets, 2070 controllers, detector sensor cards,

2018 conflict monitors and AC/DC isolator cards. The contractor will be responsible for grounding systems, mounting hardware for 2070 cabinets and all necessary hardware.

BURNING RESTRICTIONS:

(7-1-95)

200, 210, 215

SP2 R05

Open burning is not permitted on any portion of the right-of-way limits established for this project. Do not burn the clearing, grubbing or demolition debris designated for disposal and generated from the project at locations within the project limits, off the project limits or at any waste or borrow sites in this county. Dispose of the clearing, grubbing and demolition debris by means other than burning, according to state or local rules and regulations.

LABOR ASSISTANCE ON AN “AS NEEDED BASIS”

Description

At the description of the Engineer, the Contractor may be directed to assist NCDOT personnel on an ‘As Needed Basis’. Said work shall be paid on a ‘Per Hour’ basic and shall include adequate personnel to safely and efficiently perform the work as directed by the Engineer.

Measurement and Payment

Actual number of hours worked.

Payment Made Under:

Labor Assistance on an “As Needed Basis”

HR

TEMPORARY TRAFFIC CONTROL (TTC)

(7-16-13) (Rev. 12-17-15)

RWZ-1

Maintain traffic in accordance with Divisions 10, 11 and 12 of the *2018 Standard Specifications* and the following provisions:

Install Work Zone Advance Warning Signs in accordance with the detail drawing provided in these plans prior to beginning any other work. Use a lane closure or slow moving operation to complete the work, as necessary, unless otherwise indicated. Refer to Standard Drawing No. 1101.02, 1101.11, 1110.01, 1110.02, 1130.01 1135.01 and 1180.01 of the *2018 Roadway Standard Drawings*. Use a moving operation only if the minimum speed maintained at all times is 3 mph with no stops that narrow or close a lane of travel. If the moving operation is progressing slower than 3 mph at any time, install a lane closure. Maintain the existing traffic pattern at all times, except in the immediate work zone where lane closures are allowed as determined by the Engineer.

Refer to attached details and Standard Drawing No. 1101.02, 1101.03, 1101.04, 1101.05, 1101.11, 1110.01, 1110.02, 1115.01, 1130.01, 1135.01, 1145.01, 1150.01, 1165.01, and 1180.01 of the *2018 Roadway Standard Drawings* when closing a lane of travel in a stationary work zone such as pavement patching resurfacing, or pavement marking removal. Properly ballasted cones and skinny drums may be used instead of drums. However, drums are required for the upstream taper portion of lane closures in all applications. The stationary work zone shall be a maximum of 1 mile in length at any given time on 2 Lane, 2 Way facilities unless otherwise approved by the Engineer. A pilot vehicle operation may be used in conjunction with flaggers and the appropriate pilot vehicle warning signing as directed by the Engineer. During periods of construction inactivity, return the traffic pattern to the existing alignment and remove or cover any work zone signs. When covering work zone signs, use an opaque material that prevents reading of the sign at night by a driver using high beam headlights. Use material, which does not damage the sign sheeting. Replace any obliterated markings as required by other sections of the *2018 Standard Specifications* and the Engineer.

When personnel and/or equipment are working on the shoulder adjacent to and within 5 feet of an open travel lane, close the nearest open travel lane using Standard Drawing No. 1101.02 of the *2018 Roadway Standard Drawings*. When personnel and/or equipment are working within a lane of travel of an undivided facility, close the lane according to the traffic control plans, *2018 Roadway Standard Drawings* or as directed by the Engineer. Conduct the work so that all personnel and/or equipment remain within the closed travel lane. Do not work simultaneously, on both sides of an open travel way, within the same location, on a two-lane, two-way road. Perform work only when weather and visibility conditions allow safe operations as directed by the Engineer.

When utilizing a slow-moving operation for such items as pavement marking and marker placement, as a minimum the slow moving operation caravan shall consist of the vehicles and devices shown on the Moving Operation Caravan Details according to Roadway Standard Drawing No. 1101.02, sheet 11 of the *2018 Roadway Standard Drawings*. Traffic cones may be used when necessary to provide additional protection of wet pavement markings. Ballast all traffic cones so they will not be blown over by traffic.

TRAFFIC OPERATIONS:**1) Paving Lift Requirements and Time Limitations:**

For paving lifts of 2.0" or less, bring all newly resurfaced lanes to the same station and elevation within 72 hours. If not brought up to the same station and elevation within 72 hours, the Contractor shall place portable "UNEVEN PAVEMENT" signs in advance of the uneven pavement and spaced every ½ mile along the section of uneven pavement. Once mitigated, all portable "UNEVEN PAVEMENT" signs shall be removed. No additional compensation will be made for these signs or any other type of portable warning signs as these are included in the "Temporary Traffic Control" contract pay item.

For paving lifts greater than 2", bring all newly resurfaced lanes to the same station and elevation by the end of each work day unless the Contractor utilizes the notched wedge paving methods as described below.

Failure to comply with the following requirements will result in a suspension of all other operations until all lanes of traffic are brought to the same station and elevation:

- During paving operations, any paving lift greater than 2" for asphalt surface course mixes shall be mitigated by having an approved wedge apparatus on the paver that shapes the edge 1" vertically and the remaining at a maximum slope steepness of 2:1. For intermediate and base course mixes, use an approved wedge device that shapes the edge with a maximum slope steepness of 2:1. The maximum paving lift allowed to use this method is 3".
- At the end of the work day, the Contractor shall place portable "UNEVEN PAVEMENT" signs in advance of the uneven pavement and spaced every ½ mile along the section of uneven pavement. Once mitigated, all portable "UNEVEN PAVEMENT" signs shall be removed. No additional compensation will be made for these signs or any other type of portable warning signs as these are included in the "Temporary Traffic Control" contract pay item.
- In the next day's paving operation and not to exceed 72 hours, the Contractor shall bring up the adjacent lane to the same station and elevation before any further paving takes place on the project.

2) Shoulder Drop-Off Requirements and Time Limitations:

Backfill at a 6:1 slope up to the edge and elevation of existing pavement in areas adjacent to an open travel lane that has an edge of pavement drop-off as follows:

- (A) Drop-off that exceeds 2 inches on roadways with posted speed limits of 45 mph or greater.
- (B) Drop-off that exceeds 3 inches on roadways with posted speed limits less than 45 mph.

For drop-offs that exceed the above requirements, backfill the unacceptable drop-off with suitable compacted material, as approved by the Engineer. The material, equipment and labor

associated with this operation will be at no expense to the Department. This work is not considered part of shoulder reconstruction.

3) Project Requirements:

Failure to comply with the following requirements will result in a suspension of all other operations:

- 2) Before working on ANY MAP, the Contractor shall submit a written construction sequence for traffic control and construction lighting for ALL MAPS to the Engineer at the first pre- construction meeting and the sequence must be approved before closing a lane of traffic. The Contractor and Engineer will coordinate with the Traffic Management Unit at 919-773-2800 or Traffic Services for additional traffic control guidance, as necessary.
- 3) Obtain written approval of the Engineer before working in more than one location or setting up additional lane closures. The maximum length of any one lane closure is 1 mile unless otherwise directed by the Engineer.
- 4) Contractor shall mill and pave lanes in an order such that water shall not accumulate.
- 5) Traffic Control for the milling and/or paving of ramps is to be done according to Standard Drawing Number 1101.02, Sheets 9 & 10 unless otherwise approved to be closed by the Engineer. If approved, Contractor will provide plans and devices for the detour at no additional cost to the department.
- 6) If lane closure restrictions apply, see Special Provision, “Intermediate Contract Times and Liquidated Damages”.
- 7) If milled areas are not paved back within 72 hours, the Contractor is to furnish and install the following portable signs to warn drivers of the conditions. These are to include, but not limited to “Rough Road” (W8-8), “Uneven Lanes” (W8-11), and “Grooved Pavement” (W8-15) w/ Motorcycle Plaque mounted below. These are to be dual indicated on Multi-Lane Roadways with speed limits 45 mph and greater where lateral clearance can be obtained within the median areas. These portable signs are incidental to the other items of work included in the temporary traffic control (Lump Sum) pay item.

4) Work Zone Signing:

Description

Install advance/general warning work zone signs according to the Detail Drawing provided in these plans prior to beginning of work. Install and maintain signing in accordance with the attached drawings and Divisions 11 and 12 of the *2018 Standard Specifications*.

(A) Installation

All stationary Advance/General warning work zone signs require notification to existing Utility owners per Article 105-8 of the *2018 Standard Specifications* and Special Provision SP1 G115 within 3 to 12 full working days prior to installation.

Install all Advance/General warning work zone signs before beginning work on a particular map. If signs are installed more than seven (7) calendar days prior to the beginning of work on a particular map, cover the signs until the work begins. Install each work zone Advance/General warning sign separately and not on the same post or stand with any other sign except where an advisory speed plate or directional arrow is used.

All stationary signing is to be installed as shown on the detail drawing(s) unless otherwise directed by the Engineer. All sign locations to be verified by the Engineer prior to installation. Once the signs have been installed and accepted, any sign relocations requested by the Department will be compensated in accordance with Article 104-7. Any additional signs other than the ones shown in the drawing will be compensated in accordance with Article 104-7.

No stationary -Y- Line advance warning signage is required unless there's more than 1,000 feet of resurfacing along the -Y- line. Whenever work proceeds through an intersection, portable signs shall be used for traffic control. There will be no direct compensation for any portable signing.

If there is a period of construction inactivity longer than 14 calendar days, remove or cover advance/general warning work zone signs. Uncover advance/general warning work zone signs no more than 7 calendar days before work resumes. All other operations may be suspended upon failure to comply with the above requirements. Such suspended operations would not be resumed until the above requirements are fulfilled.

(B) Sign Removal

All stationary work zone signs shall be removed once the project is substantially complete. The project is substantially complete when the resurfacing operations are completed and the shoulders are brought up to the same elevation as the proposed pavement and when pavement markings are installed. The pavement marking doesn't have to be the final marking material to be considered substantially complete. Any remaining punch list items are to be completed with portable work zone signing. There will be no compensation for any portable signing. Sign removal is a condition of final project acceptance.

(C) Lane Closure Work Zone Signs

Install any required lane closure signing needed during the life of the project in accordance with the Standard Drawing No. 1101.02, 1101.11 and 1110.02 of the *2018 Roadway Standard Drawings*. Any required portable signs for lane closures are compensated in the contract pay item for *Temporary Traffic Control*.

Measurement and Payment:

Full lane closures will be the only payment made for the signing and traffic control items including Truck Mounted Impact Attenuators (TMIA - see Section 1165 of the *Standard Specifications* and the *Roadway Standard Drawings*). Full lane closures will only be used when deemed necessary by the Engineer. All other traffic control work will be considered incidental to the various other bid items in the contract.

Full Lane closures will be measured and paid for as the actual number of lane closures installed as directed by the Engineer. No direct payment will be made for providing other traffic control as required herein, as the cost of same will be considered incidental to the work being paid for under those various traffic control items that have been included. Where the Contractor maintains traffic as required herein but no specific pay items have been included in the contract, all associated costs will be considered incidental to the work being paid for under the various items in the contract.

Payment Made Under:

Full Lane Closure

EA

2.00 LIGHT STANDARD LIGHT EMITTING DIODE (LED) LUMINAIRES

2.10 DESCRIPTION

Furnish, install and place into satisfactory operation luminaire, either on a bracket arm or directly mounted to the standard, complete with all light sources, drivers, wiring inside standard from circuit conductors to luminaire, in-line breakaway fuseholders and fuses and ground wiring at the pole on light standards less than 55 ft. in height.

Type	HPS Replacement Equivalent	Color Temp	Min. % of initial output at 70k hours	Min. Maintained Delivered Lumens
185W LED	250W	3500K ±500K	83%	15,500
285W LED	400W	3500K ±500K	83%	19,150

Contractor shall submit photo metric calculations showing proposed LED Luminaire meets the spacing requirement as directed by the engineer.

The manufacturer shall state the Light Loss Factor (LLF) used in the photometric calculations for the proposed luminaire. LLF shall be calculated as follows:

$$\text{LLF} = \text{Lamp Lumen Depreciation (LLD)} \times \text{Luminaire Dirt Depreciation (LDD)}$$

- Lamp Lumen Depreciation (LLD) shall be the value calculated and reported by the manufacturer based on the LM-80 and TM-21 reports for the proposed fixture for 70,000 hours at 25° C.
- Luminaire Dirt Depreciation (LDD) = 0.90

2.20 MATERIALS

2.21 LUMINAIRE REQUIREMENTS

- General Requirements
- LM-79 photometric test reports shall be provided for all LED luminaires. LM-79 luminaire photometric reports shall be produced by an independent test laboratory and include the following:
 - Name of test laboratory. The test laboratory must hold National Voluntary Laboratory Accreditation Program (NVLAP) accreditation for the IES LM-79 test procedure or must be qualified, verified, and recognized through the U.S. Department of Energy's CALiPER program.
 - Report number
 - Date
 - Complete luminaire catalog number. Catalog number tested must match the catalog number of the luminaire submitted, except for variations which do not affect performance.
 - Description of luminaire, LED light source(s), and LED driver(s)
 - Goniophotometry
 - Colorimetry
- LM-80 lumen maintenance test report shall be provided for each respective LED light source.

- Luminaire shall be constructed of a single piece die cast aluminum housing. Each luminaire shall be finished gray in color unless otherwise noted.
 - The luminaire shall have a 7 pin ANSI C136.41 compliant photocontrol receptacle for future expansion capabilities.
 - Provide a summary of reliability testing performed for LED driver.
 - Luminaires maximum total power consumption shall not exceed the values shown in the table above. Nominal luminaire input wattage shall account for nominal applied voltage and any reduction in driver efficiency due to sub-optimal driver loading.
 - Luminaire shall have a maximum Backlight, Uplight & Glare (BUG) rating of 3-0-3 and an IESNA distribution of Type II or Type III as required to meet the spacing, the average maintained footcandle level and the average to minimum uniformity ratio requirements shown on the plans. The same BUG rating and distribution type shall be used throughout the project.
 - Minimum Ingress Protection (IP) dust and moisture ratings for the luminaire electrical components (driver and surge protection) and luminaire optical components shall be IP65 and IP66, respectively, as specified in ANSI C136.25.
 - Luminaire shall have external and internal labels per ANSI C136.15 and ANSI C136.22, respectively. Internal label shall identify the manufacturer, year and month of manufacture and the manufacturer's part number.
 - Luminaire shall have an internal bubble level.
 - Luminaires shall start and operate in -20°C to +40°C ambient.
 - Luminaires shall be rated for continuous service at an ambient temperature of 40°C (104°F)
 - Electrically test fully assembled luminaires before shipment from factory.
 - Effective Projected Area (EPA) and weight of the luminaires shall not exceed 1.4 square feet and 46 lbs.
 - Luminaires shall be designed for ease of electrical component replacement.
 - Luminaires shall be rated for minimum 2G vibration, minimum, per ANSI C136.31.
 - LED light sources and drivers shall be RoHS compliant.
 - The luminaire manufacturer shall have no less than five (5) years of experience in manufacturing LED-based lighting products and the manufacturing facility must be ISO 9001 certified.
 - Luminaire shall have a 1.25" to 2.0" adjustable tenon mount for connection to luminaire bracket arm assembly.
 - Pole hardware, nuts, bolts, and washers, etc. shall be made from 18-8 stainless steel, or steel conforming to ASTM A307 galvanized in accordance with ASTM A153.
 - Grommets shall be installed in cable entry holes. Cable entry holes shall be free from sharp edges which might cut conductors or an ungloved hand.
 - All conductors inside the luminaire shall be neatly secured with tie-wraps as needed to prevent pinch points and assist in trouble shooting.
- Driver
 - A. Shall be 0V-10V dimmable.
 - B. Rated case temperature shall be suitable for operation in the luminaire operating in the ambient temperature range of -20°C to +40°C.
 - C. Shall be rated for 480VAC at 50/60 Hz, and shall operate normally for input voltage fluctuations of $\pm 10\%$.

- D. Shall have a minimum Power Factor (PF) of 0.90 at full input power and across specified voltage range.
- E. Shall provide UL Class II output.
- Surge Suppression
 - Integral surge protection shall meet ANSI/IEEE C62.45 procedures based on ANSI/IEEE C62.41.2 definitions for standard and optional waveforms for location category C-High 10kV/10kA test, IEC 61000-4-2 (Electrostatic Discharge) 8kV Air/4kV Contact test and IEC 61000-4-4 (Fast Transients).
 - Electromagnetic interference
 - Luminaires shall have a maximum Total Harmonic Distortion (THD) of 20% at full input power and across specified voltage range.
 - Luminaires shall comply with FCC 47 CFR part 15 non-consumer RFI/EMI standards.
 - Electrical safety testing
 - Luminaires shall be listed for wet locations.
 - Luminaires shall be UL listed and labeled.
 - Finish
 - Luminaires shall be painted with a corrosion resistant polyester powdered paint with a minimum 2.0 mil thickness.
 - Luminaires shall exceed a rating of six per ASTM D1654 after 1000 hours of salt spray fog testing per ASTM B117.
 - The coating shall exhibit no greater than 30% reduction of gloss per ASTM D523, after 500 hours of QUV testing at ASTM G154 Cycle 6.
 - Exterior surfaces shall be smooth and free of burrs.
 - Thermal management
 - Mechanical design of protruding external surfaces (heat sink fins) on roadway luminaries shall facilitate hose-down cleaning and discourage debris accumulation.
 - Liquids or moving parts will not be allowed for thermal management.
 - Color Quality
 - Minimum Color Rendering Index (CRI) of 70 with a Correlated Color Temperature (CCT) of 3000K to 4000K
 - Optics
 - Transmissive optical components shall be applied in accordance with OEM design guidelines to ensure suitability for the thermal/mechanical/chemical environment.
 - The following shall be in accordance with corresponding sections of ANSI C136.37
 - All internal components shall be assembled and pre-wired using modular electrical connections.

- Terminal blocks shall be used for incoming AC lines. Terminal blocks shall be easily accessible to installers or repair personnel. Wire nuts are prohibited inside the luminaire housing.
 - Latching and hinging
- Refractor and housing door holders and hinges shall be designed to maintain positive control of door to the luminaire body so as not to allow the accidental disengagement of either door.
- Drivers shall be mounted to a housing door designed to be opened from the bottom of the luminaire. Housing door shall allow easy removal for troubleshooting/repair on the ground.
 - Manufacturer or local sales representative shall provide installation and troubleshooting support via telephone and/or email.

2.30 WARRANTY

Provide a minimum ten-year warranty covering maintained integrity and functionality of the luminaire housing, wiring, and connections, LED light source(s) and LED driver. Negligible light output from more than 10 percent of the LED packages constitutes luminaire failure.

Warranty period shall begin after project acceptance by the Department. Supplier shall furnish documentation of warranty procedures to the Contractor stating that warranty is for NCDOT.

2.40 CONSTRUCTION METHODS

Level and secure each luminaire in all directions. Adjust any luminaires, as directed by the Engineer, to provide optimal illumination distribution.

All LED packages on all luminaires must be operating normally at contract completion. Any luminaire displaying improper operating characteristics prior to contract completion will be replaced by the Contractor at no additional cost to the Department.

2.50 MEASUREMENT AND PAYMENT

The roadway luminaries measured as provided above will be paid for at the contract unit price per each "Roadway Light Standard Luminaires – LED". Such price and payment will be considered full compensation for providing and installing the LED roadway luminaire on the bracket arm, wiring inside the standard from the circuit conductors to the LED roadway luminaire, in-line breakaway fuse holders with fuses and ground wiring at the pole on the light standard.

Payment Made Under:

Roadway Light Standard Luminaire – 185W (Max) LED	EA
Roadway Light Standard Luminaire – 285W (Max) LED	EA

BREAKAWAY FUSE HOLDER**DESCRIPTION**

Furnish and install inline breakaway fuse holders as directed by the Engineer.

MATERIAL

Use breakaway fuse holders that are weatherproof and 600 V rated.

MEASURE AND PAYMENT

Breakaway fuse holders will be measured and paid for as actual number of each that have been installed and accepted.

Payment Made Under:

Breakaway Fuse Holder (Weatherproof, 600 V)	EA
---	----

SITE SURVEY**Description**

An onsite visit done by contractor to add in the design of an intersection as directed by the Engineer.

Measurement and Payment

Actual number of site surveys, arranged, conducted, and accepted.

Payment Made Under:

Site Survey	EA
-------------	----

NEW ELECTRICAL SERVICE**Description**

Furnish and install electrical system as directed by the Engineer.

Material

Refer to Division 10

Item

Electrical Service Equipment

Section

1098-1

Furnish material, equipment, and hardware that is pre-approved on the ITS and Signals QPL.

Measurement and Payment

Actual number of Electrical services installed and accepted.

Payment Made Under:

New Electrical Service

EA

CCTV CAMERA ASSEMBLY:

DESCRIPTION

Furnish and install High Definition (1080p) CCTV field equipment described in these Project Special Provisions. Ensure equipment is fully compatible with all features of the existing *VideoPro* video management software currently in use by NCDOT in this Region.

Contact the Regional ITS Engineer to confirm all CCTV locations prior to beginning construction.

MATERIAL

General

Furnish and install new CCTV camera assemblies at the locations shown on the Plans. Each assembly consists of the following:

- One Dome CCTV camera that contains in a single enclosed unit the following functionality and accessories:
 - CCTV color digital signal processing camera unit with zoom lens, filter, control circuit, and accessories
 - Motorized pan, tilt, and zoom
 - Pole-mount camera attachment assembly
 - All necessary cable, connectors and incidental hardware to make a complete and operable system
- A lightning arrestor installed in-line between the CCTV camera and the equipment cabinet components.
- A NEMA Type 4 enclosure constructed of aluminum with a clear acrylic dome or approved equal Camera Unit housing.

A. Camera and Lens

B. 1. Cameras

Furnish new charged-coupled device (CCD) color cameras. Furnish cameras with automatic gain control (AGC) for clear images in varying light levels. The camera must meet the following minimum requirements:

- Video signal format: NTSC compatible resolution, user selectable up to a maximum of 1920x1080 (1080p),
- Image sensor resolution: 768 horizontal pixels by 752 vertical pixels,
- Automatic gain control (AGC): 0-20 dB, peak-average adjustable,
- White balance: Automatic through the lens with manual override,
- Electronic-shutter: Dip-switch selectable NTSC electronic shutter with speed range from 1/2 of a second (off) to 1/30,000 of a second (NTSC),
- Overexposure protection: Built-in circuitry or a protection device to prevent any damage to the camera when pointed at strong light sources, including the sun,
- Gain control: Automatic and manual,
- Sensitivity: 1.5 lux at 90% scene reflectance,

- Sync system: Internal AC line lock, phase adjustable using remote control, V-sync,
- Signal to noise ratio: Greater than 50 dB,
- Video output connection: 1-volt peak to peak, 75 ohms terminated, BNC connector, and
- Primary voltage: 120 VAC,
- Camera voltage: 24 VAC or 24 VDC, and
- Camera power: 73 VA with heater at 24 VAC or 3A at 24 VDC.

C. 2. Zoom Lens

Provide each camera with a motorized zoom lens with automatic iris control with manual override and neutral density spot filter. Provide lenses that meet the following optical specifications:

- Automatic focus: Automatic with manual override,
- Horizontal angle of view: 55.4 degrees at 3.6 mm wide zoom and 2.9 degrees at 82 mm telephoto zoom,
- Focal length: 3.6 mm to 124 mm, 30X optical zoom, 12X electronic zoom,
- Zoom Speed: 2.9, 4.2 and 5.8 seconds,
- Lens aperture: Minimum of f/1.6,
- Maximum Sensitivity at 30 IRE: .07 lux at 1/2 second color, .2 lux at 1/60 second black and white, .015 lux at 1/2 sec. black and white,
- Preset positioning: Minimum of 128 presets.

The lens must be capable of both automatic and remote manual control iris and focus override operation. The lens must be equipped for remote control of zoom and focus, including automatic movement to any of the preset zoom and focus positions. Provide mechanical or electrical means to protect the motors from overrunning in extreme positions. The operating voltages of the lens must be compatible with the outputs of the camera control.

D. Camera Housing

Furnish new dome style enclosure for the CCTV assemblies. Equip each housing with mounting assembly for attachment to the CCTV camera pole. The enclosures must be equipped with a sunshield and be fabricated from corrosion resistant aluminum and finished in a neutral color of weather resistant enamel. The enclosure must meet or exceed NEMA 4X ratings. The viewing area of the enclosure must be tempered glass.

E. Pan and Tilt Unit

Equip each new dome style assembly with a pan and tilt unit. The pan and tilt unit must be integral to the high performance integrated dome system. The pan and tilt unit must be rated for outdoor operation, provide dynamic braking for instantaneous stopping, prevent drift, and have minimum backlash. The pan and tilt units must meet or exceed the following specifications:

- Pan: Continuous 360 degrees,
- Tilt: +2 to -92 degrees minimum,
- Presets: Minimum of 128 presets,

- Preset accuracy: .1 degree,
 - Preset pan speed: .1 degrees/second to 200 degrees/second,
 - Preset tilt speed: .1 degrees/second to 400 degrees/second,
 - Privacy zones: Minimum of eight user configurable shapes,
 - Input voltage: 24 VDC or 24 VAC, and
 - Motors: Two-phase induction type, continuous duty, instantaneous reversing.
- Preset Positioning: 64 PTZ presets per camera

F. Control Receiver/Driver

Provide each new camera unit with a control receiver/driver that is integral to the CCTV dome assembly. The control receiver/driver will receive serial asynchronous data initiated from a camera control unit, decode the command data, perform error checking, and drive the pan/tilt unit, camera controls, and motorized lens. As a minimum, the control receiver/drivers must provide the following functions:

- Zoom in/out
- Automatic focus with manual override
- Tilt up/down
- Automatic iris with manual override
- Pan right/left
- Minimum 64 preset positions for pan, tilt, and zoom

In addition, each control receiver/driver must accept status information from the pan/tilt unit and motorized lens for preset positioning of those components. The control receiver/driver will relay pan, tilt, zoom, and focus positions from the field to the remote camera control unit. The control receiver/driver must accept “goto” preset commands from the camera control unit, decode the command data, perform error checking, and drive the pan/tilt and motorized zoom lens to the correct preset position. The preset commands from the camera control unit will consist of unique values for the desired pan, tilt, zoom, and focus positions.

G. CCTV Camera Attachment to Pole

At locations shown in the Plans where new CCTV cameras are to be installed on new CCTV poles, furnish an attachment assembly for the CCTV camera unit. Use stainless steel banding approved by the Engineer. Submit shop drawings for review and approval by the Engineer prior to installation.

Furnish CCTV attachments that allow for the removal and replacement of the CCTV enclosure as well as providing a weatherproof, weather tight, seal that does not allow moisture to enter the enclosure.

Furnish a CCTV Camera Attachment Assembly that is able to withstand wind loading at the maximum wind speed and gust factor called for in these Special Provisions and can support a minimum camera unit dead load of 45 pounds (20.4 kg).

H. Surge Suppression

Protect all equipment at the top of the pole grounded metal oxide varistors connecting each power conductor to ground.

Protect coaxial cable from each camera by a surge protector at each end of the cable.

CONSTRUCTION METHODS

• **General**

Mount CCTV camera units at a height sufficient to adequately see traffic in all directions and as approved by the Engineer. The maximum attachment height is 45 feet above ground level.

Mount the CCTV camera units such that a minimum 5 feet of clearance is maintained between the camera and the top of the pole.

Obtain approval of the camera locations and orientation from the Engineer prior to installing the CCTV camera assemblies.

Mount CCTV cameras on the side of poles nearest intended field of view. Avoid occluding the view with the pole.

I. Electrical and Mechanical Requirements

Ground all equipment as called for in the Standard Specifications, these Special Provisions, and the Plans.

Install surge protectors on all ungrounded conductors entering the CCTV enclosure. House the protectors in a small, ventilated weatherproof cabinet attached near the CCTV attachment point in a manner approved by the Engineer.

MEASUREMENT AND PAYMENT

CCTV camera assembly will be measured and paid as the actual number of CCTV assemblies furnished, installed, integrated, and accepted. No separate measurement will be made for cabling, connectors, CCTV camera attachment assemblies, conduit, condulets, grounding equipment, surge protectors, CCTV control software, or any other equipment or labor required to install the CCTV assembly.

No separate payment will be made for coaxial cable. Coaxial cable, furnished and installed in the quantities required, will be incidental to the "CCTV Assembly" pay item.

Payment will be made under:

Pay Item	Pay
Unit	
CCTV Camera Assembly	Each

REPLACE PEDESTRIAN PUSH BUTTONS**Description**

Install NCDOT provided pedestrian push buttons as directed by the Engineer.

Material

NCDOT will provide pedestrian push buttons that are on the QPL list.

Construction Methods

Remove existing pedestrian push buttons and replace with NCDOT supplied buttons.

Measurement and Payment

Actual number of pedestrian push buttons replaced.

Payment Made Under:

Replaced Pedestrian Push Button	EA
---------------------------------	----

ADJUST SPAN & GUY WIRE ATTACHMENTS**Description**

Make adjustments to span wire and guy assemblies were directed by the Engineer.

Construction Methods

Adjust span wire and down guys to straighten poles and/or to adjust signal head height when directed by the Engineer.

Measurement and Payment

Actual number of intersections adjusted.

Payment Made Under

Adjust Span & Guy Wire Attachments	EA
------------------------------------	----

ANCHOR BOLTS AND TEMPLATES**Description**

Provide anchor bolts and templates for NCDOT reused poles.

Material

The NCDOT will supply pole specifications for the contractor to have the anchor bolts and templates manufactured to spec. The anchor bolts will range in size from 1 ¼" X 60" to 2" X 60" and come with 2 galvanized washers and 2 bolts and 2 black washers and 2 bolts. The templates will range in size from a 22" bolt circle to a 30" bolt circle with an eight-bolt pattern.

Measurement and Payment

Actual number of anchor bolts and all related hardware provided.
Actual number of pairs of templates provided.

Payment Made Under:

Anchor Bolts	EA
Templates	EA

TRAFFIC SIGNAL WOOD POLE REMOVAL**Description**

The contractor shall remove existing traffic signal wood pole and associated hardware including any risers and down guys as directed by the Engineer.

Construction Methods

Remove all wood poles, messenger cable attachments, risers attached to the pole, and down guys attached to the removed pole. The contractor shall take ownership of all materials.

Measurement and Payment

Actual number of wood poles removed.

Payment Made Under:

Traffic Signal Wood Pole Removal	EA
----------------------------------	----

VEHICLE SIGNAL HEAD REMOVAL**Description**

The contractor shall remove existing vehicle signal heads and associated hardware directed by the Engineer.

Construction Methods

Remove all vehicle signal heads and saddles from the messenger cable. The contractor shall take ownership of all related material.

Measurement and Payment

Actual number of vehicle signal heads removed.

Payment Made Under:

Vehicle Signal Heads Removal	EA
------------------------------	----

INSTALL RADAR VEHICLE DETECTION SYSTEM**Description**

Install NCDOT provided out of street Radar Vehicle Detection system as directed by the Engineer.

Material

NCDOT will provide Radar Vehicle Detection systems that are on the QPL list.

Construction Methods

Install NCDOT supplied Radar Vehicle Detection cable and sensor as shown on signal plans or directed by the Engineer.

Measurement and Payment

Actual number of NCDOT provided Radar Vehicle Detection Sensors installed.
Actual linear feet of NCDOT provided Radar Vehicle Detection Cable installed

Payment Made Under:

Radar Vehicle Detection Sensors	EA
Radar Vehicle Detection Cable	LF

MESSENGER CABLE REMOVAL**Description**

The contractor shall remove existing messenger cable and associated hardware as directed by the Engineer.

Construction Methods

Remove all messenger cable, signal cable attached, and related hardware. The contractor shall take ownership of all materials.

Measurement and Payment

Actual Linear Feet of messenger cable removed.

Payment Made Under:

Messenger Cable Removal LF

TRIPLEX (#6 GAUGE)**Description**

Install NCDOT supplied number 6 triplex where directed by the Engineer.

Material

The NCDOT will supply triplex consisting of two number 6 shielded and one number 6 bare.

Construction Methods

Install triplex where needed either to extend or install service. Contractor must terminate both ends using the proper size Burndy compression connectors.

Measurement and Payment

Actual linear feet of installed #6 triplex.

Payment Made Under

Triplex (#6 Gauge) LF

FOUNDATIONS AND ANCHOR ROD ASSEMBLIES FOR METAL POLES:

(1-17-12) (Rev. 1-16-18)

9, 14, 17

SP9 R05

Description

Foundations for metal poles include foundations for signals, cameras, overhead and dynamic message signs (DMS) and high mount and light standards supported by metal poles or upright trusses. Foundations consist of footings with pedestals and drilled piers with or without grade beams or wings. Anchor rod assemblies consist of anchor rods (also called anchor bolts) with nuts and washers on the exposed ends of rods and nuts and a plate or washers on the other ends of rods embedded in the foundation.

Construct concrete foundations with the required resistances and dimensions and install anchor rod assemblies in accordance with the contract and accepted submittals. Construct drilled piers consisting of cast-in-place reinforced concrete cylindrical sections in excavated holes. Provide temporary casings or polymer slurry as needed to stabilize drilled pier excavations. Use a prequalified Drilled Pier Contractor to construct drilled piers for metal poles. Define "excavation" and "hole" as a drilled pier excavation and "pier" as a drilled pier.

This provision does not apply to foundations for signal pedestals; see Section 1743 of the *2018 Standard Specifications* and 2018 Roadway Standard Drawing No. 1743.01.

Materials

Refer to the *2018 Standard Specifications*.

Item	Section
Conduit	1091-3
Grout, Type 2	1003
Polymer Slurry	411-2(B)(2)
Portland Cement Concrete	1000
Reinforcing Steel	1070
Rollers and Chairs	411-2(C)
Temporary Casings	411-2(A)

Provide Type 3 material certifications in accordance with Article 106-3 of the *2018 Standard Specifications* for conduit, rollers, chairs and anchor rod assemblies. Store steel materials on blocking at least 12" above the ground and protect it at all times from damage; and when placing in the work make sure it is free from dirt, dust, loose mill scale, loose rust, paint, oil or other foreign materials. Load, transport, unload and store foundation and anchor rod assembly materials so materials are kept clean and free of damage. Bent, damaged or defective materials will be rejected.

Use conduit type in accordance with the contract. Use Class A concrete for footings and pedestals, Class Drilled Pier concrete for drilled piers and Class AA concrete for grade beams and wings including portions of drilled piers above bottom of wings elevations. Corrugated temporary casings may be accepted at the discretion of the Engineer. A list of approved polymer slurry products is available from:

connect.ncdot.gov/resources/Geological/Pages/Products.aspx

Provide anchor rod assemblies in accordance with the contract consisting of the following:

- (A) Straight anchor rods,
- (B) Heavy hex top and leveling nuts and flat washers on exposed ends of rods, and
- (C) Nuts and either flat plates or washers on the other ends of anchor rods embedded in foundations.

Do not use lock washers. Use steel anchor rods, nuts and washers that meet ASTM F1554 for Grade 55 rods and Grade A nuts. Use steel plates and washers embedded in concrete with a thickness of at least 1/4". Galvanize anchor rods and exposed nuts and washers in accordance with Article 1076-4 of the *2018 Standard Specifications*. It is not necessary to galvanize nuts, plates and washers embedded in concrete.

Construction Methods

Install the required size and number of conduits in foundations in accordance with the plans and accepted submittals. Construct top of piers, footings, pedestals, grade beams and wings flat, level and within 1" of elevations shown in the plans or approved by the Engineer. Provide an Ordinary Surface finish in accordance with Subarticle 825-6(B) of the *2018 Standard Specifications* for portions of foundations exposed above finished grade. Do not remove anchor bolt templates or pedestal or grade beam forms or erect metal poles or upright trusses onto foundations until concrete attains a compressive strength of at least 3,000 psi.

(A) Drilled Piers

Before starting drilled pier construction, hold a predrill meeting to discuss the installation, monitoring and inspection of the drilled piers. Schedule this meeting after the Drilled Pier Contractor has mobilized to the site. The Resident or Division Traffic Engineer, Contractor and Drilled Pier Contractor Superintendent will attend this predrill meeting.

Do not excavate holes, install piles or allow equipment wheel loads or vibrations within 20 ft of completed piers until 16 hours after Drilled Pier concrete reaches initial set.

Check for correct drilled pier alignment and location before beginning drilling. Check plumbness of holes frequently during drilling.

Construct drilled piers with the minimum required diameters shown in the plans. Install piers with tip elevations no higher than shown in the plans or approved by the Engineer.

Excavate holes with equipment of the sizes required to construct drilled piers. Depending on the subsurface conditions encountered, drilling through rock and boulders may be required. Do not use blasting for drilled pier excavations.

Contain and dispose of drilling spoils and waste concrete as directed and in accordance with Section 802 of the *2018 Standard Specifications*. Drilling spoils consist of all materials and fluids removed from excavations.

If unstable, caving or sloughing materials are anticipated or encountered, stabilize holes with temporary casings and/or polymer slurry. Do not use telescoping temporary casings. If it becomes necessary to replace a temporary casing during drilling, backfill the excavation, insert a larger casing around the casing to be replaced or stabilize the excavation with polymer slurry before removing the temporary casing.

If temporary casings become stuck or the Contractor proposes leaving casings in place, temporary casings should be installed against undisturbed material. Unless otherwise approved, do not leave temporary casings in place for mast arm poles and cantilever signs. The Engineer will determine if casings may remain in place. If the Contractor proposes leaving temporary casings in place, do not begin drilling until a casing installation method is approved.

Use polymer slurry and additives to stabilize holes in accordance with the slurry manufacturer's recommendations. Provide mixing water and equipment suitable for polymer slurry. Maintain the required slurry properties at all times except for sand content.

Define a "sample set" as slurry samples collected from mid-height and within 2 ft of the bottom of holes. Take sample sets from excavations to test polymer slurry immediately after filling holes with slurry, at least every 4 hours thereafter and immediately before placing concrete. Do not place Drilled Pier concrete until both slurry samples from an excavation meet the required polymer slurry properties. If any slurry test results do not meet the requirements, the Engineer may suspend drilling until both samples from a sample set meet the required polymer slurry properties.

Remove soft and loose material from bottom of holes using augers to the satisfaction of the Engineer. Assemble rebar cages and place cages and Drilled Pier concrete in accordance with Subarticle 411-4(E) of the *2018 Standard Specifications* except for the following:

- (1) Inspections for tip resistance and bottom cleanliness are not required,
- (2) Temporary casings may remain in place if approved, and
- (3) Concrete placement may be paused near the top of pier elevations for anchor rod assembly installation and conduit placement or
- (4) If applicable, concrete placement may be stopped at bottom of grade beam or wings elevations for grade beam or wing construction.

If wet placement of concrete is anticipated or encountered, do not place Drilled Pier concrete until a concrete placement procedure is approved. If applicable, temporary casings and fluids may be removed when concrete placement is paused or stopped in accordance with the exceptions above provided holes are stable. Remove contaminated

concrete from exposed Drilled Pier concrete after removing casings and fluids. If holes are unstable, do not remove temporary casings until a procedure for placing anchor rod assemblies and conduit or constructing grade beams or wings is approved.

Use collars to extend drilled piers above finished grade. Remove collars after Drilled Pier concrete sets and round top edges of piers.

If drilled piers are questionable, pile integrity testing (PIT) and further investigation may be required in accordance with Article 411-5 of the *2018 Standard Specifications*. A drilled pier will be considered defective in accordance with Subarticle 411-5(D) of the *2018 Standard Specifications* and drilled pier acceptance is based in part on the criteria in Article 411-6 of the *2018 Standard Specifications* except for the top of pier tolerances in Subarticle 411-6(C) of the *2018 Standard Specifications*.

If a drilled pier is under further investigation, do not grout core holes, backfill around the pier or perform any work on the drilled pier until the Engineer accepts the pier. If the drilled pier is accepted, dewater and grout core holes and backfill around the pier with approved material to finished grade. If the Engineer determines a pier is unacceptable, remediation is required in accordance with Article 411-6 of the *2018 Standard Specifications*. No extension of completion date or time will be allowed for remediation of unacceptable drilled piers or post repair testing.

Permanently embed a plate in or mark top of piers with the pier diameter and depth, size and number of vertical reinforcing bars and the minimum compressive strength of the concrete mix at 28 days.

(B) Footings, Pedestals, Grade Beams and Wings

Excavate as necessary for footings, grade beams and wings in accordance with the plans, accepted submittals and Section 410 of the *2018 Standard Specifications*. If unstable, caving or sloughing materials are anticipated or encountered, shore foundation excavations as needed with an approved method. Notify the Engineer when foundation excavation is complete. Do not place concrete or reinforcing steel until excavation dimensions and foundation material are approved.

Construct cast-in-place reinforced concrete footings, pedestals, grade beams and wings with the dimensions shown in the plans and in accordance with Section 825 of the *2018 Standard Specifications*. Use forms to construct portions of pedestals and grade beams protruding above finished grade. Provide a chamfer with a 3/4" horizontal width for pedestal and grade beam edges exposed above finished grade. Place concrete against undisturbed soil or backfill and fill in accordance with Article 410-8 of the *2018 Standard Specifications*. Proper compaction around footings and wings is critical for foundations to resist uplift and torsion forces.

(C) Anchor Rod Assemblies

Size anchor rods for design and the required projection above top of foundations. Determine required anchor rod projections from nut, washer and base plate thicknesses, the protrusion of 3 to 5 anchor rod threads above top nuts after tightening and the distance of one nut thickness between top of foundations and bottom of leveling nuts.

Protect anchor rod threads from damage during storage and installation of anchor rod assemblies. Before placing anchor rods in foundations, turn nuts onto and off rods past leveling nut locations. Turn nuts with the effort of one workman using an ordinary wrench without a cheater bar. Report any thread damage to the Engineer that requires extra effort to turn nuts.

Arrange anchor rods symmetrically about center of base plate locations as shown in the plans. Set anchor rod elevations based on required projections above top of foundations. Securely brace and hold rods in the correct position, orientation and alignment with a steel template. Do not weld to reinforcing steel, temporary casings or anchor rods.

Install top and leveling (bottom) nuts, washers and the base plate for each anchor rod assembly in accordance with the following procedure:

- (1) Turn leveling nuts onto anchor rods to a distance of one nut thickness between the top of foundation and bottom of leveling nuts. Place washers over anchor rods on top of leveling nuts.
- (2) Determine if nuts are level using a flat rigid template on top of washers. If necessary, lower leveling nuts to level the template in all directions or if applicable, lower nuts to tilt the template so the metal pole or upright truss will lean as shown in the plans. If leveling nuts and washers are not in full contact with the template, replace washers with galvanized beveled washers.
- (3) Verify the distance between the foundation and leveling nuts is no more than one nut thickness.
- (4) Place base plate with metal pole or upright truss over anchor rods on top of washers. High mount luminaires may be attached before erecting metal poles but do not attach cables, mast arms or trusses to metal poles or upright trusses at this time.
- (5) Place washers over anchor rods on top of base plate. Lubricate top nut bearing surfaces and exposed anchor rod threads above washers with beeswax, paraffin or other approved lubricant.
- (6) Turn top nuts onto anchor rods. If nuts are not in full contact with washers or washers are not in full contact with the base plate, replace washers with galvanized beveled washers.
- (7) Tighten top nuts to snug-tight with the full effort of one workman using a 12" wrench. Do not tighten any nut all at once. Turn top nuts in increments. Follow a star pattern cycling through each nut at least twice.
- (8) Repeat (7) for leveling nuts.
- (9) Replace washers above and below the base plate with galvanized beveled washers if the slope of any base plate face exceeds 1:20 (5%), any washer is not in firm

contact with the base plate or any nut is not in firm contact with a washer. If any washers are replaced, repeat (7) and (8).

- (10) With top and leveling nuts snug-tight, mark each top nut on a corner at the intersection of 2 flats and a corresponding reference mark on the base plate. Mark top nuts and base plate with ink or paint that is not water-soluble. Use the turn-of-nut method for pretensioning. Do not pretension any nut all at once. Turn top nuts in increments for a total turn that meets the following nut rotation requirements:

NUT ROTATION REQUIREMENTS (Turn-of-Nut Pretensioning Method)	
Anchor Rod Diameter, inch	Requirement
$\leq 1 \frac{1}{2}$	1/3 turn (2 flats)
$> 1 \frac{1}{2}$	1/6 turn (1 flat)

Follow a star pattern cycling through each top nut at least twice.

- (11) Ensure nuts, washers and base plate are in firm contact with each other for each anchor rod. Cables, mast arms and trusses may now be attached to metal poles and upright trusses.
- (12) Between 4 and 14 days after pretensioning top nuts, use a torque wrench calibrated within the last 12 months to check nuts in the presence of the Engineer. Completely erect mast arm poles and cantilever signs and attach any hardware before checking top nuts for these structures. Check that top nuts meet the following torque requirements:

TORQUE REQUIREMENTS	
Anchor Rod Diameter, inch	Requirement, ft-lb
7/8	180
1	270
1 1/8	380
1 1/4	420
$\geq 1 \frac{1}{2}$	600

If necessary, retighten top nuts in the presence of the Engineer with a calibrated torque wrench to within ± 10 ft-lb of the required torque. Do not overtighten top nuts.

- (13) Do not grout under base plate.

Measurement and Payment

Foundations and anchor rod assemblies for metal poles and upright trusses will be measured and paid for elsewhere in the contract.

No payment will be made for temporary casings that remain in drilled pier excavations. No payment will be made for PIT. No payment will be made for further investigation of defective piers. Further investigation of piers that are not defective will be paid as extra work in accordance

with Article 104-7 of the *2018 Standard Specifications*. No payment will be made for remediation of unacceptable drilled piers or post repair testing.

TS-1

Signals and Intelligent Transportation Systems Project Special Provisions (Version 18.2)

Contents

1.	2018 STANDARD SPECIFICATIONS FOR ROADS & STRUCTURES.....	5
1.1.	GENERAL REQUIREMENTS – CONSTRUCTION METHODS (1700-3(K))	5
1.2.	WOOD POLES – CONSTRUCTION METHODS (1720-3)	5
2.	SIGNAL HEADS.....	5
2.1.	MATERIALS	5
A.	General:.....	5
B.	Vehicle Signal Heads:.....	7
C.	Pedestrian Signal Heads:	10
D.	Signal Cable:	11
E.	Optically-Programmed Vehicle Signal Sections:	12
F.	Louvers:	12
3.	CONTROLLERS WITH CABINETS	12
3.1.	MATERIALS – TYPE 170E CONTROLLERS	12
3.2.	MATERIALS – TYPE 2070L CONTROLLERS	13
3.3.	MATERIALS – NEMA TS-1 CONTROLLERS	14
3.4.	MATERIALS – NEMA TS-2 TYPE 2 CONTROLLERS	14
3.5.	MATERIALS – GENERAL CABINETS	14
3.6.	MATERIALS – TYPE 170E CABINETS	15
A.	Type 170 E Cabinets General:.....	15
B.	Type 170 E Cabinet Electrical Requirements:.....	16
C.	Type 170 E Cabinet Physical Requirements:.....	23
D.	Model 2018 Enhanced Conflict Monitor:	26
E.	Preemption and Sign Control Box	36
3.7.	MATERIALS – NEMA TS-1 CABINETS	39
A.	NEMA TS-1 Cabinet Physical Requirements:	39
B.	NEMA TS-1 Cabinet Electrical Requirements:	41
C.	NEMA TS-1 Conflict Monitors:	45
3.8.	MATERIALS – NEMA TS-2 TYPE 1 CABINETS	46
A.	NEMA TS-2 Type 1 Cabinets General:.....	46
B.	NEMA TS-2 Type 1 Cabinet Physical Requirements:.....	46
C.	NEMA TS-2 Type 1 Cabinet Electrical Requirements:.....	47
3.9.	MATERIALS – TYPE 170 DETECTOR SENSOR UNITS	55
3.10.	MATERIALS – NEMA TS-1 DETECTORS	55
3.11.	MATERIALS – NEMA TS-2 DETECTOR CARDS AND RACKS	56
3.12.	MATERIALS – TYPE 2070E CONTROLLERS	56
3.13.	MATERIALS – TYPE 2070LX CONTROLLERS	57
4.	PUSH BUTTON INTEGRATED ACCESSIBLE PEDESTRIAN SIGNAL (APS)	57
4.1.	DESCRIPTION	57

TS-2

4.2.	MATERIALS	57
4.3.	CONSTRUCTION METHODS	58
4.4.	MEASUREMENT AND PAYMENT	59
5.	VIDEO IMAGING LOOP EMULATOR DETECTOR SYSTEMS	59
5.1.	DESCRIPTION	59
5.2.	MATERIALS	59
A.	<i>General:</i>	59
B.	<i>Loop Emulator System:</i>	61
C.	<i>Video Imaging Loop Emulator System Support:</i>	62
5.3.	CONSTRUCTION METHODS	63
5.4.	MEASUREMENT AND PAYMENT	63
6.	MICROWAVE VEHICLE DETECTOR – SINGLE ZONE	64
6.1.	DESCRIPTION	64
6.2.	MATERIALS	64
6.3.	CONSTRUCTION METHODS	65
6.4.	MEASUREMENT AND PAYMENT	65
7.	MICROWAVE VEHICLE DETECTION SYSTEM - MULTIPLE DETECTION ZONES.....	65
7.1.	DESCRIPTION	65
7.2.	MATERIALS	65
7.3.	CONSTRUCTION METHODS	66
7.4.	MEASUREMENT AND PAYMENT	66
8.	WIRELESS MAGNETIC SENSOR VEHICLE DETECTION SYSTEM	67
8.1.	DESCRIPTION	67
8.2.	MATERIALS	67
8.3.	CONSTRUCTION METHODS	68
8.4.	MEASUREMENT AND PAYMENT	69
9.	GPS UNIT.....	69
9.1.	DESCRIPTION	69
9.2.	MATERIALS	69
9.3.	CONSTRUCTION METHODS	69
9.4.	MEASUREMENT AND PAYMENT	69
10.	TEMPORARY STATIONARY TRAFFIC SIGNAL SYSTEM.....	69
10.1.	DESCRIPTION	69
10.2.	MATERIALS	70
10.3.	CONSTRUCTION METHODS	70
10.4.	MEASUREMENT AND PAYMENT	70
11.	PORTABLE TRAFFIC SIGNAL SYSTEM	71
11.1.	DESCRIPTION	71
11.2.	MATERIALS	71
11.3.	CONSTRUCTION METHODS	73
11.4.	MEASUREMENT AND PAYMENT	74
12.	TRAFFIC SIGNAL SUPPORTS.....	74
12.1.	METAL TRAFFIC SIGNAL SUPPORTS – ALL POLES	74
A.	<i>General:</i>	74
B.	<i>Materials:</i>	77
C.	<i>Construction Methods:</i>	78
12.2.	METAL POLE UPRIGHTS (VERTICAL MEMBERS)	78
A.	<i>Materials:</i>	78
B.	<i>Construction Methods:</i>	80
12.3.	MAST ARMS.....	80

TS-3

A.	Materials:	81
B.	Construction Methods:	81
12.4.	DRILLED PIER FOUNDATIONS FOR METAL TRAFFIC SIGNAL POLES	81
A.	Description:	82
B.	Soil Test and Foundation Determination:	82
C.	Drilled Pier Construction:	84
12.5.	CUSTOM DESIGN OF TRAFFIC SIGNAL SUPPORTS	84
A.	General:	84
B.	Metal Poles:	85
C.	Mast Arms:	88
12.6.	METAL SIGNAL POLE REMOVALS	88
A.	Description:	88
B.	Construction Methods:	88
12.7.	POLE NUMBERING SYSTEM	88
A.	New Poles	88
B.	Reused Poles	89
12.8.	REUSED POLE SHAFTS AND/OR MAST ARMS	89
12.9.	MEASUREMENT AND PAYMENT	89
13.	PROTECTIVE COATING FOR METAL POLES	90
13.1.	DESCRIPTION	90
13.2.	MATERIALS	90
13.3.	COATING SHOP APPROVAL	90
13.4.	POWDER COATING	91
A.	Galvanizing	91
B.	Surface Preparation	92
C.	Powder Coating Application and Curing	92
D.	Quality Control	92
E.	Storage, Shipping, and Handling	92
F.	Repair of Powder Coated Material	93
13.5.	ACRYLIC PRIMER AND TOP COAT PAINT SYSTEM 4 (MODIFIED)	93
A.	Description	93
B.	Surface Preparation	93
C.	Materials	94
D.	Painting	94
E.	Curing	94
F.	Inspection	94
G.	Handling	94
H.	Repair of Damaged Coating	95
13.6.	MEASUREMENT AND PAYMENT	95
14.	JUNCTION BOX MARKERS	95
14.1.	DESCRIPTION	95
14.2.	MATERIALS	95
A.	Junction Box Markers	95
14.3.	CONSTRUCTION METHODS	97
B.	Junction Box Markers	97
14.4.	MEASUREMENT AND PAYMENT	97
15.	BACK PULL FIBER OPTIC CABLE	97
15.1.	DESCRIPTION	97
15.2.	CONSTRUCTION	97
15.3.	MEASUREMENT AND PAYMENT	98
16.	SPLICE CABINET (FIBER OPTICS)	98
16.1.	DESCRIPTION	98
16.2.	MATERIALS	98

TS-4

16.3.	CONSTRUCTION METHODS	98
A.	<i>General:</i>	98
B.	<i>Pole Mounted:</i>	98
C.	<i>Base Mounted:</i>	98
16.4.	MEASUREMENT AND PAYMENT	98
17.	ETHERNET EDGE SWITCH.....	99
17.1.	DESCRIPTION	99
A.	<i>Ethernet Edge Switch:</i>	99
B.	<i>Network Management:</i>	99
17.2.	MATERIALS	99
A.	<i>General:</i>	99
B.	<i>Compatibility Acceptance</i>	99
C.	<i>Standards:</i>	100
D.	<i>Functional:</i>	100
E.	<i>Physical Features:</i>	101
F.	<i>Management Capabilities:</i>	101
G.	<i>Electrical Specifications:</i>	103
H.	<i>Environmental Specifications:</i>	103
I.	<i>Ethernet Patch Cable:</i>	103
17.3.	CONSTRUCTION METHODS	104
A.	<i>General:</i>	104
B.	<i>Edge Switch:</i>	104
17.4.	MEASUREMENT AND PAYMENT	104
18.	COMMUNICATIONS SYSTEM SUPPORT EQUIPMENT	104
18.1.	DESCRIPTION	104
18.2.	MATERIALS	104
A.	<i>General:</i>	104
B.	<i>Fiber-Optic Support Equipment</i>	105
C.	<i>Wireless Radio Support Equipment</i>	107
18.3.	MEASUREMENT AND PAYMENT	107
19.	FIBER-OPTIC TRAINING	107
19.1.	DESCRIPTION	107
19.2.	MATERIALS	107
19.3.	MEASUREMENT AND PAYMENT	109
20.	MODIFY SPREAD SPECTRUM WIRELESS RADIO	109
20.1.	DESCRIPTION	109
20.2.	MATERIALS	109
20.3.	CONSTRUCTION METHODS	109
20.7.	MEASUREMENT AND PAYMENT	110
21.	SOLAR POWER, 900 MHZ SPREAD SPECTRUM RADIO	110
21.1.	DESCRIPTION	110
21.2.	MATERIALS	111
A.	<i>900MHz Wireless Radio System:</i>	111
B.	<i>Solar Powered Assembly:</i>	111
21.3.	CONSTRUCTION METHODS	114
A.	<i>Antenna Mounting:</i>	114
B.	<i>Solar Power Assembly:</i>	114
21.4.	MEASUREMENT AND PAYMENT	115

TS-5

1. 2018 STANDARD SPECIFICATIONS FOR ROADS & STRUCTURES

The 2018 Standard Specifications are revised as follows:

1.1. GENERAL REQUIREMENTS – Construction Methods (1700-3(K))

Page 17-4, revise sentence starting on line 14 to read “Modify existing electrical services, as necessary, to meet the grounding requirements of the NEC, these *Standard Specifications*, *Standard Drawings*, and the project plans.”

Page 17-4, revise sentence beginning on line 21 to read “Furnish and install additional ground rods to grounding electrode system as necessary to meet the *Standard Specifications*, *Standard Drawings*, and test requirements.”

1.2. WOOD POLES – Construction Methods (1720-3)

Page 17-18, revise sentence starting on line 13 to read “On new Department-owned poles, install a grounding system consisting of #6 AWG solid bare copper wire that is mechanically crimped using an irreversible compression tool with die to a single ground rod installed at base of pole or to the electrical service grounding electrode system located within 10 feet of the pole.”

2. SIGNAL HEADS

2.1. MATERIALS

A. General:

Fabricate vehicle signal head housings and end caps from die-cast aluminum. Fabricate 12-inch and 16-inch pedestrian signal head housings and end caps from die-cast aluminum. Fabricate 9-inch pedestrian signal head housings, end caps, and visors from virgin polycarbonate material. Provide visor mounting screws, door latches, and hinge pins fabricated from stainless steel. Provide interior screws, fasteners, and metal parts fabricated from stainless steel.

Fabricate tunnel and traditional visors from sheet aluminum.

Paint all surfaces inside and outside of signal housings and doors. Paint outside surfaces of tunnel and traditional visors, wire outlet bodies, wire entrance fitting brackets and end caps when supplied as components of messenger cable mounting assemblies, pole and pedestal mounting assemblies, and pedestrian pushbutton housings. Have electrostatically-applied, fused-polyester paint in highway yellow (Federal Standard 595C, Color Chip Number 13538) a minimum of 2.5 to 3.5 mils thick. Do not apply paint to the latching hardware, rigid vehicle signal head mounting brackets for mast-arm attachments, messenger cable hanger components or balance adjuster components.

Have the interior surfaces of tunnel and traditional visors painted an alkyd urea black synthetic baking enamel with a minimum gloss reflectance and meeting the requirements of MIL-E-10169, “Enamel Heat Resisting, Instrument Black.”

Where required, provide polycarbonate signal heads and visors that comply with the provisions pertaining to the aluminum signal heads listed on the QPL with the following exceptions:

Fabricate signal head housings, end caps, and visors from virgin polycarbonate material. Provide UV stabilized polycarbonate plastic with a minimum thickness of 0.1 ± 0.01 inches that is highway yellow (Federal Standard 595C, Color Chip 13538). Ensure the color is incorporated into the plastic material before molding the signal head housings and end caps. Ensure the plastic

TS-6

formulation provides the following physical properties in the assembly (tests may be performed on separately molded specimens):

Test	Required	Method
Specific Gravity	1.17 minimum	ASTM D 792
Flammability	Self-extinguishing	ASTM D 635
Tensile Strength, yield, PSI	8500 minimum	ASTM D 638
Izod impact strength, ft-lb/in [notched, 1/8 inch]	12 minimum	ASTM D 256

For pole mounting, provide side of pole mounting assemblies with framework and all other hardware necessary to make complete, watertight connections of the signal heads to the poles and pedestals. Fabricate the mounting assemblies and frames from aluminum with all necessary hardware, screws, washers, etc. to be stainless steel. Provide mounting fittings that match the positive locking device on the signal head with the serrations integrally cast into the brackets. Provide upper and lower pole plates that have a 1 ¼-inch vertical conduit entrance hubs with the hubs capped on the lower plate and 1 ½-inch horizontal hubs. Ensure that the assemblies provide rigid attachments to poles and pedestals so as to allow no twisting or swaying of the signal heads. Ensure that all raceways are free of sharp edges and protrusions, and can accommodate a minimum of ten Number 14 AWG conductors.

For pedestal mounting, provide a post-top slipfitter mounting assembly that matches the positive locking device on the signal head with serrations integrally cast into the slipfitter. Provide stainless steel hardware, screws, washers, etc. Provide a minimum of six 3/8 X 3/4-inch long square head bolts for attachment to pedestal. Provide a center post for multi-way slipfitters.

For light emitting diode (LED) traffic signal modules, provide the following requirements for inclusion on the Department's Qualified Products List for traffic signal equipment.

1. Sample submittal,
2. Third-party independent laboratory testing results for each submitted module with evidence of testing and conformance with all of the Design Qualification Testing specified in section 6.4 of each of the following Institute of Transportation Engineers (ITE) specifications:
 - Vehicle Traffic Control Signal Heads – Light Emitting Diode (LED) Circular Signal Supplement
 - Vehicle Traffic Control Signal Heads – Light Emitting Diode (LED) Vehicle Arrow Traffic Signal Supplement
 - Pedestrian Traffic Control Signal Indications –Light Emitting Diode (LED) Signal Modules.

(Note: The Department currently recognizes two approved independent testing laboratories. They are Intertek ETL Semko and Light Metrics, Incorporated with Garwood Laboratories. Independent laboratory tests from other laboratories may be considered as part of the QPL submittal at the discretion of the Department,

3. Evidence of conformance with the requirements of these specifications,
4. A manufacturer's warranty statement in accordance with the required warranty, and

TS-7

5. Submittal of manufacturer's design and production documentation for the model, including but not limited to, electrical schematics, electronic component values, proprietary part numbers, bill of materials, and production electrical and photometric test parameters.
6. Evidence of approval of the product to bear the Intertek ETL Verified product label for LED traffic signal modules.

In addition to meeting the performance requirements for the minimum period of 60 months, provide a written warranty against defects in materials and workmanship for the modules for a period of 60 months after installation of the modules. During the warranty period, the manufacturer must provide new replacement modules within 45 days of receipt of modules that have failed at no cost to the State. Repaired or refurbished modules may not be used to fulfill the manufacturer's warranty obligations. Provide manufacturer's warranty documentation to the Department during evaluation of product for inclusion on Qualified Products List (QPL).

B. Vehicle Signal Heads:

Comply with the ITE standard "Vehicle Traffic Control Signal Heads". Provide housings with provisions for attaching backplates.

Provide visors that are 8 inches in length for 8-inch vehicle signal head sections. Provide visors that are 10 inches in length for 12-inch vehicle signal heads.

Provide a termination block with one empty terminal for field wiring for each indication plus one empty terminal for the neutral conductor. Have all signal sections wired to the termination block. Provide barriers between the terminals that have terminal screws with a minimum Number 8 thread size and that will accommodate and secure spade lugs sized for a Number 10 terminal screw.

Mount termination blocks in the yellow signal head sections on all in-line vehicle signal heads. Mount the termination block in the red section on five-section vehicle signal heads.

Furnish vehicle signal head interconnecting brackets. Provide one-piece aluminum brackets less than 4.5 inches in height and with no threaded pipe connections. Provide hand holes on the bottom of the brackets to aid in installing wires to the signal heads. Lower brackets that carry no wires and are used only for connecting the bottom signal sections together may be flat in construction.

For messenger cable mounting, provide messenger cable hangers, wire outlet bodies, balance adjusters, bottom caps, wire entrance fitting brackets, and all other hardware necessary to make complete, watertight connections of the vehicle signal heads to the messenger cable. Fabricate messenger cable hanger components, wire outlet bodies and balance adjuster components from stainless steel or malleable iron galvanized in accordance with ASTM A153 (Class A) or ASTM A123. Provide serrated rings made of aluminum. Provide messenger cable hangers with U-bolt clamps. Fabricate washers, screws, hex-head bolts and associated nuts, clevis pins, cotter pins, U-bolt clamps and nuts from stainless steel.

For mast-arm mounting, provide rigid vehicle signal head mounting brackets and all other hardware necessary to make complete, watertight connections of the vehicle signal heads to the mast arms and to provide a means for vertically adjusting the vehicle signal heads to proper alignment. Fabricate the mounting assemblies from aluminum, and provide serrated rings made of aluminum. Provide stainless steel cable attachment assemblies to secure the brackets to the mast arms. Ensure all fastening hardware and fasteners are fabricated from stainless steel.

TS-8

Provide LED vehicular traffic signal modules (hereafter referred to as modules) that consist of an assembly that uses LEDs as the light source in lieu of an incandescent lamp for use in traffic signal sections. Use LEDs that are aluminum indium gallium phosphorus (AlInGaP) technology for red and yellow indications and indium gallium nitride (InGaN) for green indications. Install the ultra bright type LEDs that are rated for 100,000 hours of continuous operation from -40°F to +165°F. Design modules to have a minimum useful life of 60 months and to meet all parameters of this specification during this period of useful life.

For the modules, provide spade terminals crimped to the lead wires and sized for a #10 screw connection to the existing terminal block in a standard signal head. Do not provide other types of crimped terminals with a spade adapter.

Ensure the power supply is integral to the module assembly. On the back of the module, permanently mark the date of manufacture (month & year) or some other method of identifying date of manufacture.

Tint the red, yellow and green lenses to correspond with the wavelength (chromaticity) of the LED. Transparent tinting films are unacceptable. Provide a lens that is integral to the unit with a smooth outer surface.

1. LED Circular Signal Modules:

Provide modules in the following configurations: 12-inch circular sections, and 8-inch circular sections. All makes and models of LED modules purchased for use on the State Highway System shall appear on the current NCDOT Traffic Signal Qualified Products List (QPL).

Provide the manufacturer's model number and the product number (assigned by the Department) for each module that appears on the 2018 or most recent Qualified Products List. In addition, provide manufacturer's certification in accordance with Article 106-3 of the *Standard Specifications*, that each module meets or exceeds the ITE "Vehicle Traffic Control Signal Heads – Light Emitting Diode (LED) Circular Signal Supplement" dated June 27, 2005 (hereafter referred to as VTCSH Circular Supplement) and other requirements stated in this specification.

Provide modules that meet the following requirements when tested under the procedures outlined in the VTCSH Circular Supplement:

Module Type	Max. Wattage at 165° F	Nominal Wattage at 77° F
12-inch red circular	17	11
8-inch red circular	13	8
12-inch green circular	15	15
8-inch green circular	12	12

For yellow circular signal modules, provide modules tested under the procedures outlined in the VTCSH Circular Supplement to insure power required at 77° F is 22 Watts or less for the 12-inch circular module and 13 Watts or less for the 8-inch circular module.

Note: Use a wattmeter having an accuracy of $\pm 1\%$ to measure the nominal wattage and maximum wattage of a circular traffic signal module. Power may also be derived from voltage, current and power factor measurements.

TS-9

2. LED Arrow Signal Modules

Provide 12-inch omnidirectional arrow signal modules. All makes and models of LED modules purchased for use on the State Highway System shall appear on the current NCDOT Traffic Signal Qualified Products List (QPL).

Provide the manufacturer's model number and the product number (assigned by the Department) for each module that appears on the 2018 or most recent Qualified Products List. In addition, provide manufacturer's certification in accordance with Article 106-3 of the *Standard Specifications*, that each module meets or exceeds the requirements for 12-inch omnidirectional modules specified in the ITE "Vehicle Traffic Control Signal Heads – Light Emitting Diode (LED) Vehicle Arrow Traffic Signal Supplement" dated July 1, 2007 (hereafter referred to as VTCSH Arrow Supplement) and other requirements stated in this specification.

Provide modules that meet the following requirements when tested under the procedures outlined in the VTCSH Arrow Supplement:

Module Type	Max. Wattage at 165° F	Nominal Wattage at 77° F
12-inch red arrow	12	9
12-inch green arrow	11	11

For yellow arrow signal modules, provide modules tested under the procedures outlined in the VTCSH Arrow Supplement to insure power required at 77° F is 12 Watts or less.

Note: Use a wattmeter having an accuracy of $\pm 1\%$ to measure the nominal wattage and maximum wattage of an arrow traffic signal module. Power may also be derived from voltage, current and power factor measurements.

3. LED U-Turn Arrow Signal Modules:

Provide modules in the following configurations: 12-inch left u-turn arrow signal modules and 12-inch right u-turn arrow signal modules.

Modules are not required to be listed on the ITS and Signals Qualified Products List. Provide manufacturer's certification in accordance with Article 106-3 of the *Standard Specifications*, that each module meets or exceeds the ITE "Vehicle Traffic Control Signal Heads – Light Emitting Diode (LED) Circular Signal Supplement" dated June 27, 2005 (hereafter referred to as VTCSH Circular Supplement) and other requirements stated in this specification.

Provide modules that have minimum maintained luminous intensity values that are not less than 16% of the values calculated using the method described in section 4.1 of the VTCSH Circular Supplement.

Provide modules that meet the following requirements when tested under the procedures outlined in the VTCSH Circular Supplement:

Module Type	Max. Wattage at 165° F	Nominal Wattage at 77° F
12-inch red u-turn arrow	17	11
12-inch green u-turn arrow	15	15

For yellow u-turn arrow signal modules, provide modules tested under the procedures outlined in the VTCSH Circular Supplement to ensure power required at 77° F is 22 Watts or less.

TS-10

Note: Use a wattmeter having an accuracy of $\pm 1\%$ to measure the nominal wattage and maximum wattage of a circular traffic signal module. Power may also be derived from voltage, current and power factor measurements.

C. Pedestrian Signal Heads:

Provide pedestrian signal heads with international symbols that meet the MUTCD. Do not provide letter indications.

Comply with the ITE standard for “Pedestrian Traffic Control Signal Indications” and the following sections of the ITE standard for “Vehicle Traffic Control Signal Heads” in effect on the date of advertisement:

- Section 3.00 - “Physical and Mechanical Requirements”
- Section 4.01 - “Housing, Door, and Visor: General”
- Section 4.04 - “Housing, Door, and Visor: Materials and Fabrication”
- Section 7.00 - “Exterior Finish”

Provide a double-row termination block with three empty terminals and number 10 screws for field wiring. Provide barriers between the terminals that accommodate a spade lug sized for number 10 terminal screws. Mount the termination block in the hand section. Wire all signal sections to the terminal block.

Where required by the plans, provide 16-inch pedestrian signal heads with traditional three-sided, rectangular visors, 6 inches long. Where required by the plans, provide 12-inch pedestrian signal heads with traditional three-sided, rectangular visors, 8 inches long.

Provide 2-inch diameter pedestrian push-buttons with weather-tight housings fabricated from die-cast aluminum and threading in compliance with the NEC for rigid metal conduit. Provide a weep hole in the housing bottom and ensure that the unit is vandal resistant.

Provide push-button housings that are suitable for mounting on flat or curved surfaces and that will accept 1/2-inch conduit installed in the top. Provide units that have a heavy duty push-button assembly with a sturdy, momentary, normally-open switch. Have contacts that are electrically insulated from the housing and push-button. Ensure that the push-buttons are rated for a minimum of 5 mA at 24 volts DC and 250 mA at 12 volts AC.

Provide standard R10-3 signs with mounting hardware that comply with the MUTCD in effect on the date of advertisement. Provide R10-3E signs for countdown pedestrian heads and R10-3B for non-countdown pedestrian heads.

Design the LED pedestrian traffic signal modules (hereafter referred to as modules) for installation into standard pedestrian traffic signal sections that do not contain the incandescent signal section reflector, lens, eggcrate visor, gasket, or socket. Provide modules that consist of an assembly that uses LEDs as the light source in lieu of an incandescent lamp. Use LEDs that are of the latest aluminum indium gallium phosphorus (AlInGaP) technology for the Portland Orange hand and countdown displays. Use LEDs that are of the latest indium gallium nitride (InGaN) technology for the Lunar White walking man displays. Install the ultra-bright type LEDs that are rated for 100,000 hours of continuous operation from -40°F to $+165^{\circ}\text{F}$. Design modules to have a minimum useful life of 60 months and to meet all parameters of this specification during this period of useful life.

TS-11

Design all modules to operate using a standard 3 - wire field installation. Provide spade terminals crimped to the lead wires and sized for a #10 screw connection to the existing terminal block in a standard pedestrian signal housing. Do not provide other types of crimped terminals with a spade adapter.

Ensure the power supply is integral to the module assembly. On the back of the module, permanently mark the date of manufacture (month & year) or some other method of identifying date of manufacture.

Provide modules in the following configuration: 16-inch displays which have the solid hand/walking man overlay on the left and the countdown on the right, and 12-inch displays which have the solid hand/walking man module as an overlay. All makes and models of LED modules purchased for use on the State Highway System shall appear on the current NCDOT Traffic Signal Qualified Products List (QPL).

Provide the manufacturer's model number and the product number (assigned by the Department) for each module that appears on the 2018 or most recent Qualified Products List. In addition, provide manufacturer's certification in accordance with Article 106-3 of the *Standard Specifications*, that each module meets or exceeds the ITE "Pedestrian Traffic Control Signal Indicators - Light Emitting Diode (LED) Signal Modules" dated August 04, 2010 (hereafter referred to as PTCSI Pedestrian Standard) and other requirements stated in this specification.

Provide modules that meet the following requirements when tested under the procedures outlined in the PTCSI Pedestrian Standard:

Module Type	Max. Wattage at 165° F	Nominal Wattage at 77° F
Hand Indication	16	13
Walking Man Indication	12	9
Countdown Indication	16	13

Note: Use a wattmeter having an accuracy of $\pm 1\%$ to measure the nominal wattage and maximum wattage of a circular traffic signal module. Power may also be derived from voltage, current and power factor measurements.

Provide module lens that is hard coated or otherwise made to comply with the material exposure and weathering effects requirements of the Society of Automotive Engineers (SAE) J576. Ensure all exposed components of the module are suitable for prolonged exposure to the environment, without appreciable degradation that would interfere with function or appearance.

Ensure the countdown display continuously monitors the traffic controller to automatically learn the pedestrian phase time and update for subsequent changes to the pedestrian phase time.

Ensure the countdown display begins normal operation upon the completion of the preemption sequence and no more than one pedestrian clearance cycle.

D. Signal Cable:

Furnish 16-4 and 16-7 signal cable that complies with IMSA specification 20-1 except provide the following conductor insulation colors:

- For 16-4 cable: white, yellow, red, and green

TS-12

- For 16-7 cable: white, yellow, red, green, yellow with black stripe tracer, red with black stripe tracer, and green with black stripe tracer. Apply continuous stripe tracer on conductor insulation with a longitudinal or spiral pattern.

Provide a ripcord to allow the cable jacket to be opened without using a cutter. IMSA specification 19-1 will not be acceptable. Provide a cable jacket labeled with the IMSA specification number and provide conductors constructed of stranded copper.

E. Optically-Programmed Vehicle Signal Sections:

Material, equipment, and hardware furnished under this section must be pre-approved on the Department's QPL by the date of installation.

Design the programmable signal sections to tilt in two degree increments for a maximum of ten degrees above and ten degrees below horizontal, while still maintaining a common vertical axis.

Design the programmable signal sections to mount to standard signal sections to form a signal head. Ensure that the programmable signal sections have a mounting system compatible with the standard 1 ½-inch traffic signal fittings.

Provide an optical system consisting of a lamp, a diffuser, an optical limiter, and an objective lens. Ensure that all programming is accomplished optically with no hoods or louvers necessary to accomplish the programming. Provide optical masking tape with each section.

Provide a 150-Watt, 115 VAC lamp with integral reflector and rated output of 1750 lumens. Ensure that the average rated life is at least 6000 hours.

Provide a high resolution, annular, incremental lens. Ensure that the lens and door are sealed to provide a moisture and dust proof seal. Provide a red, yellow, or green ball or arrow indication as specified by the bid list, plans, or purchase order.

F. Louvers:

Material, equipment, and hardware furnished under this section must be pre-approved on the Department's QPL by the date of installation.

Provide louvers made from sheet aluminum. Paint the louvers alkyd urea black synthetic baked enamel with a minimum gloss reflectance and meeting the requirements of MIL-E-10169, "Enamel Heat Resisting, Instrument Black."

Ensure that the louvers have a 0-degree horizontal viewing angle. Provide a minimum of 5 vanes.

3. CONTROLLERS WITH CABINETS

3.1. MATERIALS – TYPE 170E CONTROLLERS

Conform to the CALTRANS *Traffic Signal Control Equipment Specifications* and addendum 8, *Specifications for Model 170E Enhanced Controller Unit and Associated Model 412C and Model 172 Modules* except as required herein.

Provide model 412C Program Modules as defined in CALTRANS Addendum 8 except as specified otherwise herein. Provide program module delivery with Memory Select #4 Configuration except that all RAM must be DALLAS Non-volatile RAM or an approved equal. Ensure that the removal of the program module from the controller will place the intersection into flash.

TS-13

Provide diagnostic software or removable diagnostic PROM modules that will test and diagnose the following:

- systems of the controller, including the internal memory, Program Module, Real Time Clock, I/O circuitry, display, and keyboard;
- systems of the cabinet, including the output file, input file, police panel, flashing operation, and cabinet switches; and
- systems of the conflict monitor by checking all possible conflicts in a logical sequence and resetting the conflict monitor each time, and by testing red failure function and red detect cable disconnects.

Ensure that the automatic reset function can be enabled by inserting a diagnostic plug in the jack labeled “Conflict Monitor Test” in the “TEST” position.

In addition to CALTRANS system communications capability between a central computer and master controller and master to local controller communications, provide communications capability with the intersection conflict monitor via an RS-232C/D port on the monitor. Ensure controller receives data from the conflict monitor through a controller Asynchronous Communications Interface Adapter (ACIA) determined by the controller software manufacturer. Ensure that with the appropriate software, the controller is capable of communicating directly through a laptop nine pin serial port to the same monitor RS-232C/D to retrieve all event log information.

Furnish a communications connecting cable with the following pin connections.

170		Conflict Monitor DB-9
RX pin L	Connect to	TX pin 2
TX pin K	Connect to	RX pin 3
+5 pin D	Connect to	DTR pin 4
GND pin N	Connect to	GND pin 5

Provide a male DB-9 connector on the cable for connection to the monitor.

Provide socket mounting for through-hole mount devices with 14 or more pins. Ensure that all sockets are AUGAT-500 series machined sockets, or equal.

Provide a moisture resistant coating on all circuit boards. Mount circuit boards vertically.

3.2. MATERIALS – TYPE 2070L CONTROLLERS

Conform to CALTRANS *Transportation Electrical Equipment Specifications* (TEES) (dated August 16, 2002, plus Errata 1 dated October 27, 2003 and Errata 2 dated June 08, 2004) except as required herein.

Furnish Model 2070L controllers. Ensure that removal of the CPU module from the controller will place the intersection into flash.

The Department will provide software at the beginning of the burning-in period. Contractor shall give 5 working days notice before needing software. Program software provided by the Department.

Provide model 2070L controllers with the latest version of OS9 operating software and device drivers, composed of the unit chassis and at a minimum the following modules and assemblies:

TS-14

- MODEL 2070 1B, CPU Module, Single Board
- MODEL 2070-2A, Field I/O Module (FI/O)
 - Note: Configure the Field I/O Module to disable both the External WDT Shunt/Toggle Switch and SP3 (SP3 active indicator is “off”)
- MODEL 2070-3B, Front Panel Module (FP), Display B (8x40)
- MODEL 2070-4A, Power Supply Module, 10 AMP
- MODEL 2070-7A, Async Serial Com Module (9-pin RS-232)

Furnish one additional MODEL 2070-7A, Async Serial Com Module (9-pin RS-232) for all master controller locations.

For each master location and central control center, furnish a U.S. Robotics V.92 or approved equivalent auto-dial/auto-answer external modem to accomplish the interface to the Department-furnished microcomputers. Include all necessary hardware to ensure telecommunications.

3.3. MATERIALS – NEMA TS-1 CONTROLLERS

Furnish NEMA TS-1 controller (*insert model number here*), or approved equivalent. Include a NEMA standard overlap card.

Ensure that all components are arranged for easy access during servicing. When modular in construction, provide guides and positive connection devices to insure proper pin alignment and connection.

Provide a moisture resistant coating on all circuit boards.

3.4. MATERIALS – NEMA TS-2 TYPE 2 CONTROLLERS

Furnish NEMA TS-2, Type 2 (*insert model number here*), or approved equivalent. Include a NEMA standard overlap card.

Ensure that all components are arranged for easy access during servicing. When modular in construction, provide guides and positive connection devices to insure proper pin alignment and connection.

Provide a moisture resistant coating on all circuit boards.

3.5.MATERIALS – GENERAL CABINETS

Provide a moisture resistant coating on all circuit boards.

Provide one 20 mm diameter radial lead UL-recognized metal oxide varistor (MOV) between each load switch field terminal and equipment ground. Electrical performance is outlined below.

TS-15

PROPERTIES OF MOV SURGE PROTECTOR	
Maximum Continuous Applied Voltage at 185° F	150 VAC (RMS) 200 VDC
Maximum Peak 8x20µs Current at 185° F	6500 A
Maximum Energy Rating at 185° F	80 J
Voltage Range 1 mA DC Test at 77° F	212-268 V
Max. Clamping Voltage 8x20µs, 100A at 77° F	395 V
Typical Capacitance (1 MHz) at 77° F	1600 pF

Provide a power line surge protector that is a two-stage device that will allow connection of the radio frequency interference filter between the stages of the device. Ensure that a maximum continuous current is at least 10A at 120V. Ensure that the device can withstand a minimum of 20 peak surge current occurrences at 20,000A for an 8x20 microsecond waveform. Provide a maximum clamp voltage of 395V at 20,000A with a nominal series inductance of 200µh. Ensure that the voltage does not exceed 395V. Provide devices that comply with the following:

Frequency (Hz)	Minimum Insertion Loss (dB)
60	0
10,000	30
50,000	55
100,000	50
500,000	50
2,000,000	60
5,000,000	40
10,000,000	20
20,000,000	25

3.6. MATERIALS – TYPE 170E CABINETS

A. Type 170 E Cabinets General:

Conform to the city of Los Angeles' Specification No. 54-053-08, *Traffic Signal Cabinet Assembly Specification* (dated July 2008), except as required herein.

Furnish model 336S pole mounted cabinets configured for 8 vehicle phases, 4 pedestrian phases, and 6 overlaps. Do not reassign load switches to accommodate overlaps unless shown on electrical

TS-16

details. Provide 336S pole mounted cabinets that are 46” high with 40” high internal rack assemblies.

Furnish model 332 base mounted cabinets configured for 8 vehicle phases, 4 pedestrian phases, and 6 overlaps. When overlaps are required, provide auxiliary output files for the overlaps. Do not reassign load switches to accommodate overlaps unless shown on electrical details.

Provide model 200 load switches, model 222 loop detector sensors, model 252 AC isolators, and model 242 DC isolators according to the electrical details. As a minimum, provide one (1) model 2018 conflict monitor, one (1) model 206L power supply unit, two (2) model 204 flashers, one (1) DC isolator (located in slot I14), and four (4) model 430 flash transfer relays (provide seven (7) model 430 flash transfer relays if auxiliary output file is installed) with each cabinet.

B. Type 170 E Cabinet Electrical Requirements:

Provide a cabinet assembly designed to ensure that upon leaving any cabinet switch or conflict monitor initiated flashing operation, the controller starts up in the programmed start up phases and start up interval.

Furnish two sets of non-fading cabinet wiring diagrams and schematics in a paper envelope or container and placed in the cabinet drawer.

All AC+ power is subject to radio frequency signal suppression.

Provide surge suppression in the cabinet for each type of cabinet device. Provide surge protection for the full capacity of the cabinet input file. Provide surge suppression devices that operate properly over a temperature range of -40° F to +185° F. Ensure the surge suppression devices provide both common and differential modes of protection.

Provide a pluggable power line surge protector that is installed on the back of the PDA (power distribution assembly) chassis to filter and absorb power line noise and switching transients. Ensure the device incorporates LEDs for failure indication and provides a dry relay contact closure for the purpose of remote sensing. Ensure the device meets the following specifications:

Peak Surge Current (Single pulse, 8x20µs).....	20,000A
Occurrences (8x20µs waveform).....	10 minimum @ 20,000A
Maximum Clamp Voltage.....	395VAC
Operating Current.....	15 amps
Response Time.....	< 5 nanoseconds

Provide a loop surge suppressor for each set of loop terminals in the cabinet. Ensure the device meets the following specifications:

Peak Surge Current (6 times, 8x20µs)	
(Differential Mode).....	400A
(Common Mode).....	1,000A

TS-17

Occurrences (8x20 μ s waveform).....	500 min @ 200A
Maximum Clamp Voltage	
(Differential Mode @400A).....	35V
(Common Mode @1,000A).....	35V
Response Time.....	< 5 nanoseconds
Maximum Capacitance.....	35 pF

Provide a data communications surge suppressor for each communications line entering or leaving the cabinet. Ensure the device meets the following specifications:

Peak Surge Current (Single pulse, 8x20 μ s).....	10,000A
Occurrences (8x20 μ s waveform).....	100 min @ 2,000A
Maximum Clamp Voltage.....	Rated for equipment protected
Response Time.....	< 1 nanosecond
Maximum Capacitance.....	1,500 pF
Maximum Series Resistance.....	15 Ω

Provide a DC signal surge suppressor for each DC input channel in the cabinet. Ensure the device meets the following specifications:

Peak Surge Current (Single pulse, 8x20 μ s).....	10,000A
Occurrences (8x20 μ s waveform).....	100 @ 2,000A
Maximum Clamp Voltage.....	30V
Response Time.....	< 1 nanosecond

Provide a 120 VAC signal surge suppressor for each AC+ interconnect signal input. Ensure the device meets the following specifications:

Peak Surge Current (Single pulse, 8x20 μ s).....	20,000A
Maximum Clamp Voltage.....	350VAC
Response Time.....	< 200 nanoseconds
Discharge Voltage.....	<200 Volts @ 1,000A
Insulation Resistance.....	\geq 100 M Ω

TS-18

Provide conductors for surge protection wiring that are of sufficient size (ampacity) to withstand maximum overcurrents which could occur before protective device thresholds are attained and current flow is interrupted.

If additional surge protected power outlets are needed to accommodate fiber transceivers, modems, etc., install a UL listed, industrial, heavy-duty type power outlet strip with a minimum rating of 15 A / 125 VAC, 60 Hz. Provide a strip that has a minimum of 3 grounded outlets. Ensure the power outlet strip plugs into one of the controller unit receptacles located on the rear of the PDA. Ensure power outlet strip is mounted securely; provide strain relief if necessary.

Provide a door switch in the front and a door switch in the rear of the cabinet that will provide the controller unit with a Door Ajar alarm when either the front or the rear door is open. Ensure the door switches apply DC ground to the Input File when either the front door or the rear door is open.

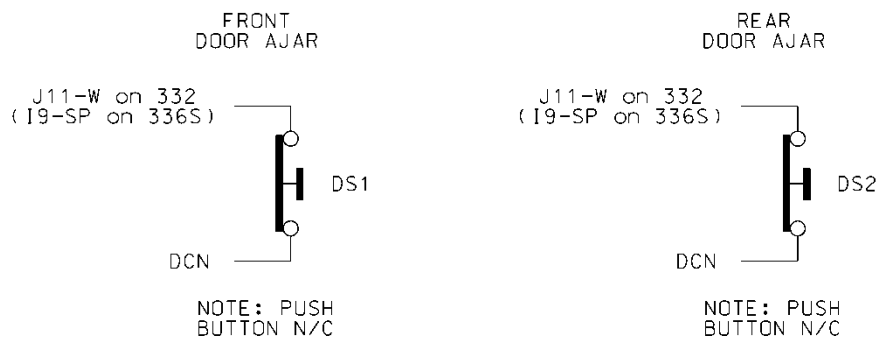

Furnish a fluorescent fixture in the rear across the top of the cabinet and another fluorescent fixture in the front across the top of the cabinet at a minimum. Ensure that the fixtures provide sufficient light to illuminate all terminals, labels, switches, and devices in the cabinet. Conveniently locate the fixtures so as not to interfere with a technician's ability to perform work on any devices or terminals in the cabinet. Provide a protective diffuser to cover exposed bulbs. Install 16 watt T-4 lamps in the fluorescent fixtures. Provide a door switch to provide power to each fixture when the respective door is open. Wire the fluorescent fixtures to the 15 amp ECB (equipment circuit breaker).

TS-19

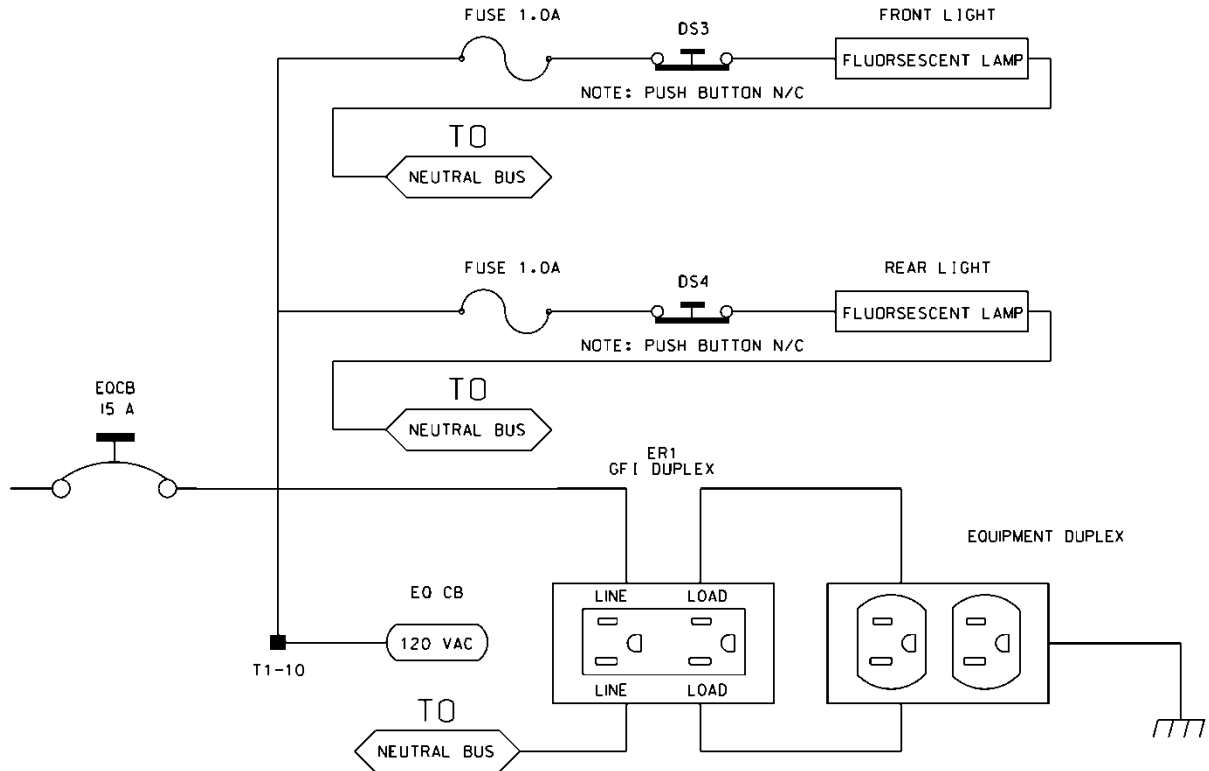

Furnish a police panel with a police panel door. For model 336S cabinets, mount the police panel on the rear door. Ensure that the police panel door permits access to the police panel when the main door is closed. Ensure that no rainwater can enter the cabinet even with the police panel door open. Provide a police panel door hinged on the right side as viewed from the front. Provide a police panel door lock that is keyed to a standard police/fire call box key. In addition to the requirements of LA Specification No. 54-053-08, provide the police panel with a toggle switch connected to switch the intersection operation between normal stop-and-go operation (AUTO) and manual operation (MANUAL). Ensure that manual control can be implemented using inputs and software such that the controller provides full programmed clearance times for the yellow clearance and red clearance for each phase while under manual control.

Provide a 1/4-inch locking phone jack in the police panel for a hand control to manually control the intersection. Provide sufficient room in the police panel for storage of a hand control and cord.

Ensure the 336S cabinet Input File is wired as follows:

TS-20

336S Cabinet														
Port-Bit/C-1 Pin Assignment														
Slot #	1	2	3	4	5	6	7	8	9	10	11	12	13	14
C-1 (Spares)	59	60	61	62	63	64	65	66	75	76	77	78	79	80
Port C-1	3-2	1-1	3-4	1-3	3-1	1-2	3-3	1-4	2-5	5-5	5-6	5-1	5-2	6-7
C-1	56	39	58	41	55	40	57	42	51	71	72	67	68	81
Port C-1	2-1	1-5	2-3	1-7	2-2	1-6	2-4	1-8	2-6	5-7	5-8	5-3	5-4	6-8
C-1	47	43	49	45	48	44	50	46	52	73	74	69	70	82

For model 332 base mounted cabinets, ensure terminals J14-E and J14-K are wired together on the rear of the Input File. Connect TB9-12 (J14 Common) on the Input Panel to T1-2 (AC-) on the rear of the PDA.

Provide detector test switches mounted at the top of the cabinet rack or other convenient location which may be used to place a call on each of eight phases based on the chart below. Provide three positions for each switch: On (place call), Off (normal detector operation), and Momentary On (place momentary call and return to normal detector operation after switch is released). Ensure that the switches are located such that the technician can read the controller display and observe the intersection.

Connect detector test switches for cabinets as follows:

336S Cabinet		332 Cabinet	
Detector Call Switches	Terminals	Detector Call Switches	Terminals
Phase 1	I1-F	Phase 1	I1-W
Phase 2	I2-F	Phase 2	I4-W
Phase 3	I3-F	Phase 3	I5-W
Phase 4	I4-F	Phase 4	I8-W
Phase 5	I5-F	Phase 5	J1-W
Phase 6	I6-F	Phase 6	J4-W
Phase 7	I7-F	Phase 7	J5-W
Phase 8	I8-F	Phase 8	J8-W

Provide the PCB 28/56 connector for the conflict monitor unit (CMU) with 28 independent contacts per side, dual-sided with 0.156 inch contact centers. Provide the PCB 28/56 connector contacts with solder eyelet terminations. Ensure all connections to the PCB 28/56 connector are soldered to the solder eyelet terminations.

TS-21

Ensure that all cabinets have the CMU connector wired according to the 332 cabinet connector pin assignments (include all wires for auxiliary output file connection). Wire pins 13, 16, R, and U of the CMU connector to a separate 4 pin plug, P1, as shown below. Provide a second plug, P2, which will mate with P1 and is wired to the auxiliary output file as shown below. Provide an additional plug, P3, which will mate with P1 and is wired to the pedestrian yellow circuits as shown below. When no auxiliary output file is installed in the cabinet, provide wires for the green and yellow inputs for channels 11, 12, 17, and 18, the red inputs for channels 17 and 18, and the wires for the P2 plug. Terminate the two-foot wires with ring type lugs, insulated, and bundled for optional use.

PIN	P1		P2		P3	
	FUNCTION	CONN TO	FUNCTION	CONN TO	FUNCTION	CONN TO
1	CH-9G	CMU-13	OLA-GRN	A123	2P-YEL	114
2	CH-9Y	CMU-16	OLA-YEL	A122	4P-YEL	105
3	CH-10G	CMU-R	OLB-GRN	A126	6P-YEL	120
4	CH-10Y	CMU-U	OLB-YEL	A125	8P-YEL	111

Do not provide the P20 terminal assembly (red monitor board) or red interface ribbon cable as specified in LA Specification No. 54-053-08.

Provide a P20 connector that mates with and is compatible with the red interface connector mounted on the front of the conflict monitor. Ensure that the P20 connector and the red interface connector on the conflict monitor are center polarized to ensure proper connection. Ensure that removal of the P20 connector will cause the conflict monitor to recognize a latching fault condition and place the cabinet into flashing operation.

Wire the P20 connector to the output file and auxiliary output file using 22 AWG stranded wires. Ensure the length of these wires is a minimum of 42 inches in length. Provide a durable braided sleeve around the wires to organize and protect the wires.

Wire the P20 connector to the traffic signal red displays to provide inputs to the conflict monitor as shown below. Ensure the pedestrian Don't Walk circuits are wired to channels 13 through 16 of the P20 connector. When no auxiliary output file is installed in the cabinet, provide wires for channels 9 through 12 reds. Provide a wire for special function 1. Terminate the unused wires with ring type lugs, insulated, and bundled for optional use.

P20 Connector					
PIN	FUNCTION	CONN TO	PIN	FUNCTION	CONN TO
1	Channel 15 Red	119	2	Channel 16 Red	110
3	Channel 14 Red	104	4	Chassis GND	01-9
5	Channel 13 Red	113	6	N/C	
7	Channel 12 Red	AUX 101	8	Spec Function 1	
9	Channel 10 Red	AUX 124	10	Channel 11 Red	AUX 114
11	Channel 9 Red	AUX 121	12	Channel 8 Red	107

TS-22

13	Channel 7 Red	122		14	Channel 6 Red	134
15	Channel 5 Red	131		16	Channel 4 Red	101
17	Channel 3 Red	116		18	Channel 2 Red	128
19	Channel 1 Red	125		20	Red Enable	01-14

Ensure the controller unit outputs to the auxiliary output file are pre-wired to the C5 connector. When no auxiliary output file is installed in the cabinet, connect the C5 connector to a storage socket located on the Input Panel or on the rear of the PDA.

Do not wire pin 12 of the load switch sockets.

In addition to the requirements of LA Specification No. 54-053-08, ensure relay K1 on the Power Distribution Assembly (PDA) is a four pole relay and K2 on the PDA is a two pole relay.

Provide a two pole, ganged circuit breaker for the flash bus circuit. Ensure the flash bus circuit breaker is an inverse time circuit breaker rated for 10 amps at 120 VAC with a minimum of 10,000 RMS symmetrical amperes short circuit current rating. Do not provide the auxiliary switch feature on the flash bus circuit breaker. Ensure the ganged flash bus circuit breaker is certified by the circuit breaker manufacturer to provide gang tripping operation.

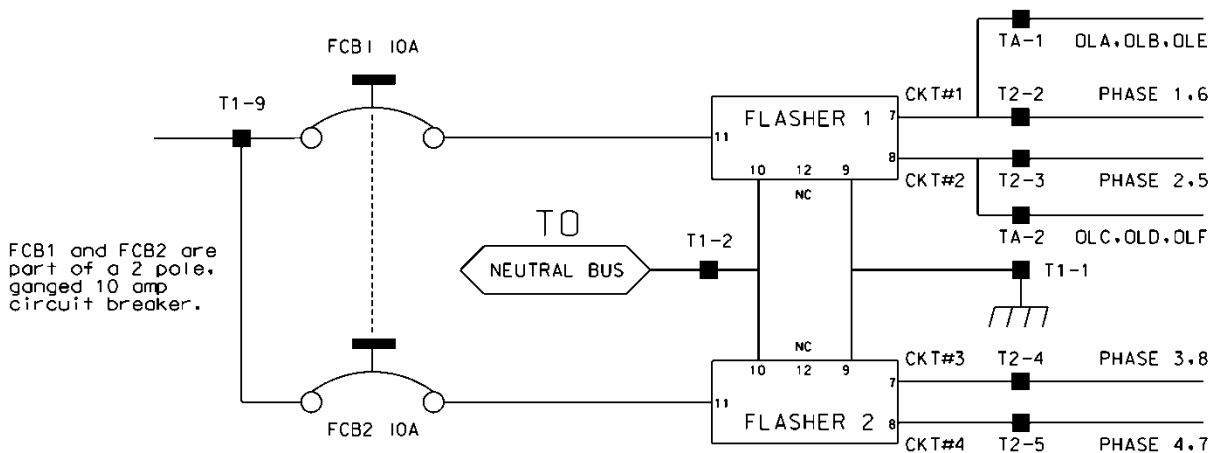

Ensure auxiliary output files are wired as follows:

TS-23

AUXILIARY OUTPUT FILE TERMINAL BLOCK TA ASSIGNMENTS	
POSITION	FUNCTION
1	Flasher Unit #1, Circuit 1/FTR1 (OLA, OLB)/FTR3 (OLE)
2	Flasher Unit #1, Circuit 2/FTR2 (OLC, OLD)/FTR3 (OLF)
3	Flash Transfer Relay Coils
4	AC -
5	Power Circuit 5
6	Power Circuit 5
7	Equipment Ground Bus
8	NC

Provide four spare load resistors mounted in each cabinet. Ensure each load resistor is rated as shown in the table below. Wire one side of each load resistor to AC-. Connect the other side of each resistor to a separate terminal on a four (4) position terminal block. Mount the load resistors and terminal block either inside the back of Output File No. 1 or on the upper area of the Service Panel.

ACCEPTABLE LOAD RESISTOR VALUES	
VALUE (ohms)	WATTAGE
1.5K – 1.9 K	25W (min)
2.0K – 3.0K	10W (min)

Provide Model 200 load switches, Model 204 flashers, Model 242 DC isolators, Model 252 AC isolators, and Model 206L power supply units that conform to CALTRANS’ *“Transportation Electrical Equipment Specifications”* dated March 12, 2009 with Erratum 1.

C. Type 170 E Cabinet Physical Requirements:

Do not mold, cast, or scribe the name “City of Los Angeles” on the outside of the cabinet door as specified in LA Specification No. 54-053-08. Do not provide a Communications Terminal Panel as specified in LA Specification No. 54-053-08. Do not provide terminal block TBB on the Service Panel. Do not provide Cabinet Verification Test Program software or associated test jigs as specified in LA Specification No. 54-053-08.

TS-24

Furnish unpainted, natural, aluminum cabinet shells. Ensure that all non-aluminum hardware on the cabinet is stainless steel or a Department approved non-corrosive alternate.

Ensure the lifting eyes, gasket channels, police panel, and all supports welded to the enclosure and doors are fabricated from 0.125 inch minimum thickness aluminum sheet and meet the same standards as the cabinet and doors.

Provide front and rear doors with latching handles that allow padlocking in the closed position. Furnish 0.75 inch minimum diameter stainless steel handles with a minimum 0.5 inch shank. Place the padlocking attachment at 4.0 inches from the handle shank center to clear the lock and key. Provide an additional 4.0 inches minimum gripping length.

Provide Corbin #2 locks on the front and rear doors. Provide one (1) Corbin #2 and one (1) police master key with each cabinet. Ensure main door locks allow removal of keys in the locked position only.

Provide a surge protection panel with 16 loop surge protection devices and designed to allow sufficient free space for wire connection/disconnection and surge protection device replacement. For model 332 cabinets, provide an additional 20 loop surge protection devices. Provide an additional two AC+ interconnect surge devices to protect one slot and eight DC surge protection devices to protect four slots. Provide no protection devices on slot I14.

For pole mounted cabinets, mount surge protection devices for the AC+ interconnect inputs, inductive loop detector inputs, and low voltage DC inputs on a swing down panel assembly fabricated from sturdy aluminum. Attach the swing down panel to the bottom rear cabinet rack assembly using thumb screws. Ensure the swing down panel allows for easy removal of the input file without removing the surge protection panel assembly or its parts. Have the surge protection devices mounted horizontally on the panel and soldered to the feed through terminals of four 14 position terminal blocks with #8 screws mounted on the other side. Ensure the top row of terminals is connected to the upper slots and the bottom row of terminals is connected to the bottom slots. Provide a 15 position copper equipment ground bus attached to the field terminal side (outside) of the swing down panel for termination of loop lead-in shield grounds. Ensure that a Number 4 AWG green wire connects the surge protection panel assembly ground bus to the main cabinet equipment ground.

TS-25

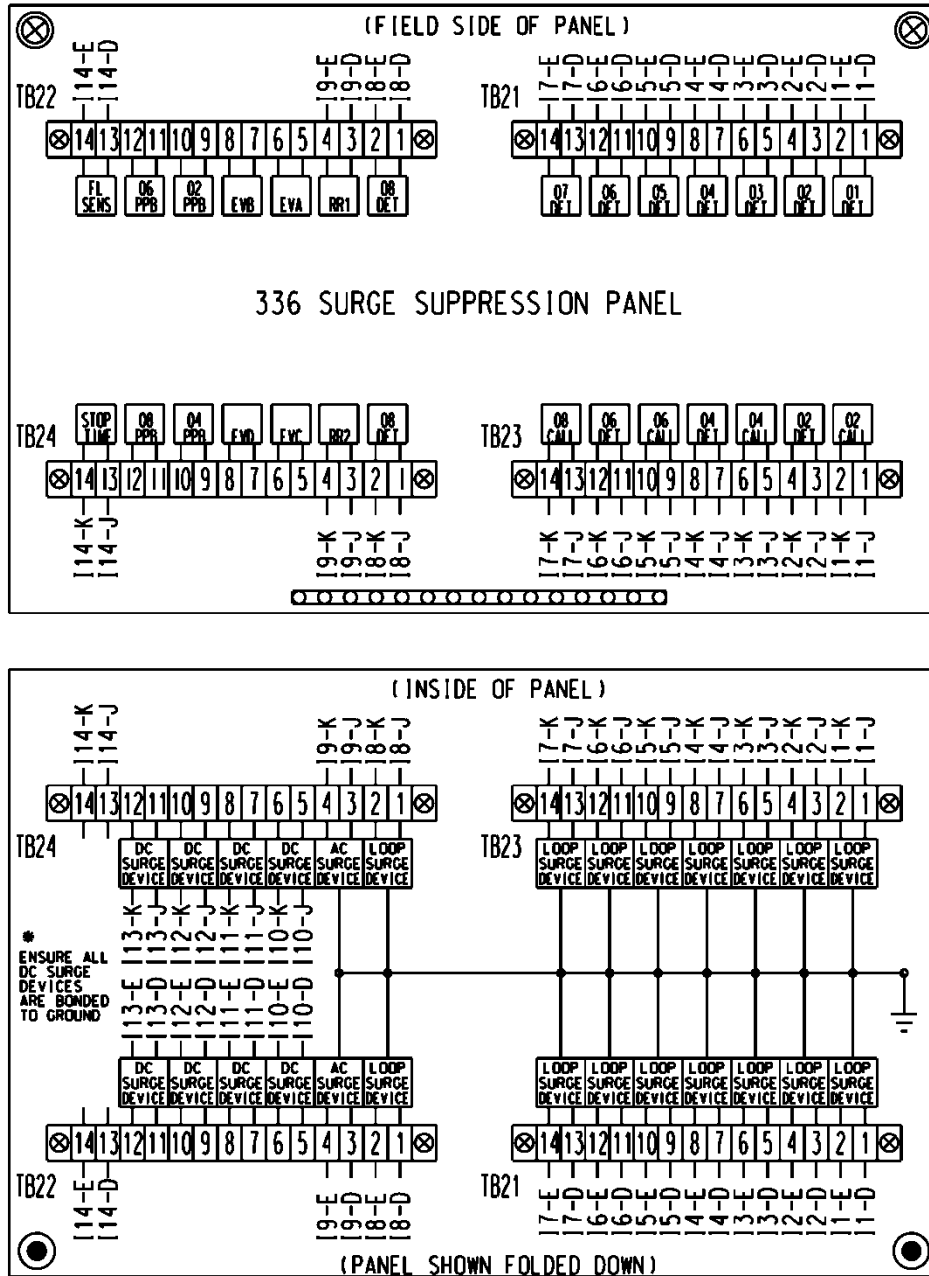

For base mounted cabinets, mount surge protection panels on the left side of the cabinet as viewed from the rear. Attach each panel to the cabinet rack assembly using bolts and make it easily removable. Mount the surge protection devices in vertical rows on each panel and connect the devices to one side of 12 position, double row terminal blocks with #8 screws. For each surge protection panel, terminate all grounds from the surge protection devices on a copper equipment ground bus attached to the surge protection panel. Wire the terminals to the rear of a standard input file using spade lugs for input file protection.

TS-26

Provide permanent labels that indicate the slot and the pins connected to each terminal that may be viewed from the rear cabinet door. Label and orient terminals so that each pair of inputs is next to each other. Indicate on the labeling the input file (I or J), the slot number (1-14) and the terminal pins of the input slots (either D & E for upper or J & K for lower).

Provide a minimum 14 x 16 inch pull out, hinged top shelf located immediately below controller mounting section of the cabinet. Ensure the shelf is designed to fully expose the table surface outside the controller at a height approximately even with the bottom of the controller. Ensure the shelf has a storage bin interior which is a minimum of 1 inch deep and approximately the same dimensions as the shelf. Provide an access to the storage area by lifting the hinged top of the shelf. Fabricate the shelf and slide from aluminum or stainless steel and ensure the assembly can support the 2070L controller plus 15 pounds of additional weight. Ensure shelf has a locking mechanism to secure it in the fully extended position and does not inhibit the removal of the 2070L controller or removal of cards inside the controller when fully extended. Provide a locking mechanism that is easily released when the shelf is to be returned to its non-use position directly under the controller.

D. Model 2018 Enhanced Conflict Monitor:

Furnish Model 2018 Enhanced Conflict Monitors that provide monitoring of 18 channels. Ensure each channel consists of a green, yellow, and red field signal input. Ensure that the conflict monitor meets or exceeds CALTRANS' Transportation Electrical Equipment Specifications dated March 12, 2009, with Erratum 1 (hereafter referred to as CALTRANS' 2009 TEES) for a model 210 monitor unit and other requirements stated in this specification.

Ensure the conflict monitor is provided with an 18 channel conflict programming card. Pin EE and Pin T of the conflict programming card shall be connected together. Pin 16 of the conflict programming card shall be floating. Ensure that the absence of the conflict programming card will cause the conflict monitor to trigger (enter into fault mode), and remain in the triggered state until the programming card is properly inserted and the conflict monitor is reset.

Provide a conflict monitor that incorporates LED indicators into the front panel to dynamically display the status of the monitor under normal conditions and to provide a comprehensive review of field inputs with monitor status under fault conditions. Ensure that the monitor indicates the channels that were active during a conflict condition and the channels that experienced a failure for all other per channel fault conditions detected. Ensure that these indications and the status of each channel are retained until the Conflict Monitor is reset. Furnish LED indicators for the following:

- AC Power (Green LED indicator)
- VDC Failed (Red LED indicator)
- WDT Error (Red LED indicator)
- Conflict (Red LED indicator)
- Red Fail (Red LED indicator)
- Dual Indication (Red LED indicator)
- Yellow/Clearance Failure (Red LED indicator)
- PCA/PC Ajar (Red LED indicator)

TS-27

- Monitor Fail/Diagnostic Failure (Red LED indicator)
- 54 Channel Status Indicators (1 Red, 1 Yellow, and 1 Green LED indicator for each of the 18 channels)

Provide a switch to set the Red Fail fault timing. Ensure that when the switch is in the ON position the Red Fail fault timing value is set to 1350 +/- 150 ms (2018 mode). Ensure that when the switch is in the OFF position the Red Fail fault timing value is set to 850 +/- 150 ms (210 mode).

Provide a switch to set the Watchdog fault timing. Ensure that when the switch is in the ON position the Watchdog fault timing value is set to 1.0 +/- 0.1 s (2018 mode). Ensure that when the switch is in the OFF position the Watchdog fault timing value is set to 1.5 +/- 0.1 s (210 mode).

Provide a jumper or switch to set the AC line brown-out levels. Ensure that when the jumper is present or the switch is in the ON position the AC line dropout voltage threshold is 98 +/- 2 Vrms, the AC line restore voltage threshold is 103 +/- 2 Vrms, and the AC line brown-out timing value is set to 400 +/- 50ms (2018 mode). Ensure that when the jumper is not present or the switch is in the OFF position the AC line dropout voltage threshold is 92 +/- 2 Vrms, the AC line restore voltage threshold is 98 +/- 2 Vrms, and the AC line brown-out timing value is set to 80 +/- 17 ms (210 mode).

Provide a jumper or switch that will enable and disable the Watchdog Latch function. Ensure that when the jumper is not present or the switch is in the OFF position the Watchdog Latch function is disabled. In this mode of operation, a Watchdog fault will be reset following a power loss, brownout, or power interruption. Ensure that when the jumper is present or the switch is in the ON position the Watchdog Latch function is enabled. In this mode of operation, a Watchdog fault will be retained until a Reset command is issued.

Provide a jumper that will reverse the active polarity for pin #EE (output relay common). Ensure that when the jumper is not present pin #EE (output relay common) will be considered 'Active' at a voltage greater than 70 Vrms and 'Not Active' at a voltage less than 50 Vrms (Caltrans mode). Ensure that when the jumper is present pin #EE (output relay common) will be considered 'Active' at a voltage less than 50 Vrms and 'Not Active' at a voltage greater than 70 Vrms (Failsafe mode).

In addition to the connectors required by CALTRANS' 2009 TEES, provide the conflict monitor with a red interface connector mounted on the front of the monitor. Ensure the connector is a 20 pin, right angle, center polarized, male connector with latching clip locks and polarizing keys. Ensure the right angle solder tails are designed for a 0.062" thick printed circuit board. Keying of the connector shall be between pins 3 and 5, and between 17 and 19. Ensure the connector has two rows of pins with the odd numbered pins on one row and the even pins on the other row. Ensure the connector pin row spacing is 0.10" and pitch is 0.10". Ensure the mating length of the connector pins is 0.24". Ensure the pins are finished with gold plating 30μ" thick.

TS-28

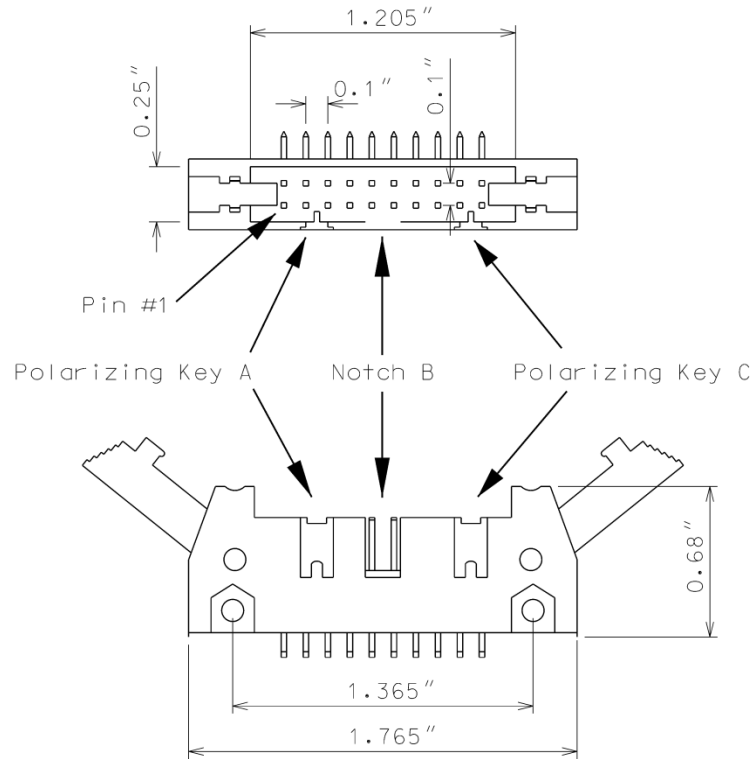

Ensure the red interface connector pins on the monitor have the following functions:

Pin #	Function	Pin #	Function
1	Channel 15 Red	2	Channel 16 Red
3	Channel 14 Red	4	Chassis Ground
5	Channel 13 Red	6	Special Function 2
7	Channel 12 Red	8	Special Function 1
9	Channel 10 Red	10	Channel 11 Red
11	Channel 9 Red	12	Channel 8 Red
13	Channel 7 Red	14	Channel 6 Red
15	Channel 5 Red	16	Channel 4 Red
17	Channel 3 Red	18	Channel 2 Red
19	Channel 1 Red	20	Red Enable

Ensure that removal of the P20 cable connector will cause the conflict monitor to recognize a latching fault condition and place the cabinet into flashing operation.

TS-29

Provide Special Function 1 and Special Function 2 inputs to the unit which shall disable only Red Fail Monitoring when either input is sensed active. A Special Function input shall be sensed active when the input voltage exceeds 70 Vrms with a minimum duration of 550 ms. A Special Function input shall be sensed not active when the input voltage is less than 50 Vrms or the duration is less than 250 ms. A Special Function input is undefined by these specifications and may or may not be sensed active when the input voltage is between 50 Vrms and 70 Vrms or the duration is between 250 ms and 550 ms.

Ensure the conflict monitor recognizes field signal inputs for each channel that meet the following requirements:

- consider a Red input greater than 70 Vrms and with a duration of at least 500 ms as an “on” condition;
- consider a Red input less than 50 Vrms or with a duration of less than 200 ms as an “off” condition (no valid signal);
- consider a Red input between 50 Vrms and 70 Vrms or with a duration between 200 ms and 500 ms to be undefined by these specifications;
- consider a Green or Yellow input greater than 25 Vrms and with a duration of at least 500 ms as an “on” condition;
- consider a Green or Yellow input less than 15 Vrms or with a duration of less than 200 ms as an “off” condition; and
- consider a Green or Yellow input between 15 Vrms and 25 Vrms or with a duration between 200 ms and 500 ms to be undefined by these specifications.

Provide a conflict monitor that recognizes the faults specified by CALTRANS’ 2009 TEES and the following additional faults. Ensure the conflict monitor will trigger upon detection of a fault and will remain in the triggered (in fault mode) state until the unit is reset at the front panel or through the external remote reset input for the following failures:

1. **Red Monitoring or Absence of Any Indication (Red Failure):** A condition in which no “on” voltage signal is detected on any of the green, yellow, or red inputs to a given monitor channel. If a signal is not detected on at least one input (R, Y, or G) of a conflict monitor channel for a period greater than 1000 ms when used with a 170 controller and 1500 ms when used with a 2070 controller, ensure monitor will trigger and put the intersection into flash. If the absence of any indication condition lasts less than 700 ms when used with a 170 controller and 1200 ms when used with a 2070 controller, ensure conflict monitor will not trigger. Red fail monitoring shall be enabled on a per channel basis by the use of switches located on the conflict monitor. Have red monitoring occur when all of the following input conditions are in effect:
 - a) Red Enable input to monitor is active (Red Enable voltages are “on” at greater than 70 Vrms, off at less than 50 Vrms, undefined between 50 and 70 Vrms), and
 - b) Neither Special Function 1 nor Special Function 2 inputs are active.

TS-30

- c) Pin #EE (output relay common) is not active
2. **Short/Missing Yellow Indication Fault (Clearance Error):** Yellow indication following a green is missing or shorter than 2.7 seconds (with ± 0.1 -second accuracy). If a channel fails to detect an “on” signal at the Yellow input for a minimum of 2.7 seconds (± 0.1 second) following the detection of an “on” signal at a Green input for that channel, ensure that the monitor triggers and generates a clearance/short yellow error fault indication. Short/missing yellow (clearance) monitoring shall be enabled on a per channel basis by the use of switches located on the conflict monitor. This fault shall not occur when the channel is programmed for Yellow Inhibit, when the Red Enable signal is inactive or pin #EE (output relay common) is active.
 3. **Dual Indications on the Same Channel:** In this condition, more than one indication (R,Y,G) is detected as “on” at the same time on the same channel. If dual indications are detected for a period greater than 500 ms, ensure that the conflict monitor triggers and displays the proper failure indication (Dual Ind fault). If this condition is detected for less than 200 ms, ensure that the monitor does not trigger. G-Y-R dual indication monitoring shall be enabled on a per channel basis by the use of switches located on the conflict monitor. G-Y dual indication monitoring shall be enabled for all channels by use of a switch located on the conflict monitor. This fault shall not occur when the Red Enable signal is inactive or pin #EE (output relay common) is active.
 4. **Configuration Settings Change:** The configuration settings are comprised of (as a minimum) the permissive diode matrix, dual indication switches, yellow disable jumpers, any option switches, any option jumpers, and the Watchdog Enable switch. Ensure the conflict monitor compares the current configuration settings with the previous stored configuration settings on power-up, on reset, and periodically during operation. If any of the configuration settings are changed, ensure that the conflict monitor triggers and causes the program card indicator to flash. Ensure that configuration change faults are only reset by depressing and holding the front panel reset button for a minimum of three seconds. Ensure the external remote reset input does not reset configuration change faults.

Ensure the conflict monitor will trigger and the AC Power indicator will flash at a rate of 2 Hz \pm 20% with a 50% duty cycle when the AC Line voltage falls below the “drop-out” level. Ensure the conflict monitor will resume normal operation when the AC Line voltage returns above the “restore” level. Ensure the AC Power indicator will remain illuminated when the AC voltage returns above the “restore” level. Should an AC Line power interruption occur while the monitor is in the fault mode, then upon restoration of AC Line power, the monitor will remain in the fault mode and the correct fault and channel indicators will be displayed.

Provide a flash interval of at least 6 seconds and at most 10 seconds in duration following a power-up, an AC Line interruption, or a brownout restore. Ensure the conflict monitor will suspend all fault monitoring functions, close the Output relay contacts, and flash the AC indicator at a rate of 4 Hz \pm 20% with a 50% duty cycle during this interval. Ensure the termination of the flash interval after at least 6 seconds if the Watchdog input has made 5 transitions between the True and False state and the AC Line voltage is greater than the “restore” level. If the watchdog input has not made

TS-31

5 transitions between the True and False state within 10 ± 0.5 seconds, the monitor shall enter a WDT error fault condition.

Ensure the conflict monitor will monitor an intersection with a minimum of four approaches using the four-section Flashing Yellow Arrow (FYA) vehicle traffic signal as outlined by the NCHRP 3-54 research project for protected-permissive left turn signal displays. Ensure the conflict monitor will operate in the FYA mode and FYAc (Compact) mode as specified below to monitor each channel pair for the following fault conditions: Conflict, Flash Rate Detection, Red Fail, Dual Indication, and Clearance. Provide a switch to select between the FYA mode and FYAc mode. Provide a switch to select each FYA phase movement for monitoring.

FYA mode

FYA Signal Head	Phase 1	Phase 3	Phase 5	Phase 7
Red Arrow	Channel 9 Red	Channel 10 Red	Channel 11 Red	Channel 12 Red
Yellow Arrow	Channel 9 Yellow	Channel 10 Yellow	Channel 11 Yellow	Channel 12 Yellow
Flashing Yellow Arrow	Channel 9 Green	Channel 10 Green	Channel 11 Green	Channel 12 Green
Green Arrow	Channel 1 Green	Channel 3 Green	Channel 5 Green	Channel 7 Green

FYAc mode

FYA Signal Head	Phase 1	Phase 3	Phase 5	Phase 7
Red Arrow	Channel 1 Red	Channel 3 Red	Channel 5 Red	Channel 7 Red
Yellow Arrow	Channel 1 Yellow	Channel 3 Yellow	Channel 5 Yellow	Channel 7 Yellow
Flashing Yellow Arrow	Channel 1 Green	Channel 3 Green	Channel 5 Green	Channel 7 Green
Green Arrow	Channel 9 Green	Channel 9 Yellow	Channel 10 Green	Channel 10 Yellow

TS-32

If a FYA channel pair is enabled for FYA operation, the conflict monitor will monitor the FYA logical channel pair for the additional following conditions:

1. **Conflict:** Channel conflicts are detected based on the permissive programming jumpers on the program card. This operation remains unchanged from normal operation except for the solid Yellow arrow (FYA clearance) signal.
2. **Yellow Change Interval Conflict:** During the Yellow change interval of the Permissive Turn channel (flashing Yellow arrow) the conflict monitor shall verify that no conflicting channels to the solid Yellow arrow channel (clearance) are active. These conflicting channels shall be determined by the program card compatibility programming of the Permissive Turn channel (flashing Yellow arrow). During the Yellow change interval of the Protected Turn channel (solid Green arrow) the conflict monitor shall verify that no conflicting channels to the solid Yellow arrow channel (clearance) are active as determined by the program card compatibility programming of the Protected Turn channel (solid Green arrow).
3. **Flash Rate Detection:** The conflict monitor unit shall monitor for the absence of a valid flash rate for the Permissive turn channel (flashing Yellow arrow). If the Permissive turn channel (flashing Yellow arrow) is active for a period greater than 1600 milliseconds, ensure the conflict monitor triggers and puts the intersection into flash. If the Permissive turn channel (flashing Yellow arrow) is active for a period less than 1400 milliseconds, ensure the conflict monitor does not trigger. Ensure the conflict monitor will remain in the triggered (in fault mode) state until the unit is reset at the front panel or through the external remote reset input. Provide a jumper or switch that will enable and disable the Flash Rate Detection function. Ensure that when the jumper is not present or the switch is in the OFF position the Flash Rate Detection function is enabled. Ensure that when the jumper is present or the switch is in the ON position the Flash Rate Detection function is disabled.
4. **Red Monitoring or Absence of Any Indication (Red Failure):** The conflict monitor unit shall detect a red failure if there is an absence of voltage on all four of the inputs of a FYA channel pair (RA, YA, FYA, GA).
5. **Dual Indications on the Same Channel:** The conflict monitor unit shall detect a dual indication if two or more inputs of a FYA channel pair (RA, YA, FYA, GA) are “on” at the same time.
6. **Short/Missing Yellow Indication Fault (Clearance Error):** The conflict monitor unit shall monitor the solid Yellow arrow for a clearance fault when terminating both the Protected Turn channel (solid Green arrow) interval and the Permissive Turn channel (flashing Yellow arrow) interval.

Ensure that the conflict monitor will log at least nine of the most recent events detected by the monitor in non-volatile EEPROM memory (or equivalent). For each event, record at a minimum the time, date, type of event, status of each field signal indication with RMS voltage, and specific channels involved with the event. Ensure the conflict monitor will log the following events: monitor reset, configuration, previous fault, and AC line. Furnish the signal sequence log that shows all channel states (Greens, Yellows, and Reds) and the Red Enable State for a minimum of 2 seconds prior to the current fault trigger point. Ensure the display resolution of the inputs for the signal sequence log is not greater than 50 ms.

TS-33

For conflict monitors used within an Ethernet communications system, provide a conflict monitor with an Ethernet 10/100 Mbps, RJ-45 port for data communication access to the monitor by a local notebook computer and remotely via a workstation or notebook computer device connected to the signal system local area network. The Ethernet port shall be electrically isolated from the conflict monitor's electronics and shall provide a minimum of 1500 Vrms isolation. Integrate monitor with Ethernet network in cabinet. Provide software to retrieve the time and date from a network server in order to synchronize the on-board times between the conflict monitor and the controller. Furnish and install the following Windows based, graphic user interface software on workstations and notebook computers where the signal system client software is installed: 1) software to view and retrieve all event log information, 2) software that will search and display a list of conflict monitor IP addresses and IDs on the network, and 3) software to change the conflict monitor's network parameters such as IP address and subnet mask.

For non-Ethernet connected monitors, provide a RS-232C/D compliant port (DB-9 female connector) on the front panel of the conflict monitor in order to provide communications from the conflict monitor to the 170/2070 controller or to a Department-furnished laptop computer. Electrically isolate the port interface electronics from all monitor electronics, excluding Chassis Ground. Ensure that the controller can receive all event log information through a controller Asynchronous Communications Interface Adapter (Type 170E) or Async Serial Comm Module (2070). Furnish and connect a serial cable from the conflict monitor's DB-9 connector to Comm Port 1 of the 2070 controller. Ensure conflict monitor communicates with the controller. Provide a Windows based graphic user interface software to communicate directly through the same monitor RS-232C/D compliant port to retrieve and view all event log information to a Department-furnished laptop computer. The RS-232C/D compliant port on the monitor shall allow the monitor to function as a DCE device with pin connections as follows:

Conflict Monitor RS-232C/D (DB-9 Female) Pinout		
Pin Number	Function	I/O
1	DCD	O
2	TX Data	O
3	RX Data	I
4	DTR	I
5	Ground	-
6	DSR	O
7	CTS	I
8	RTS	O
9	NC	-

TS-34

MONITOR BOARD EDGE CONNECTOR

Pin #	Function (Back Side)	Pin #	Function (Component Side)
1	Channel 2 Green	A	Channel 2 Yellow
2	Channel 13 Green	B	Channel 6 Green
3	Channel 6 Yellow	C	Channel 15 Green
4	Channel 4 Green	D	Channel 4 Yellow
5	Channel 14 Green	E	Channel 8 Green
6	Channel 8 Yellow	F	Channel 16 Green
7	Channel 5 Green	H	Channel 5 Yellow
8	Channel 13 Yellow	J	Channel 1 Green
9	Channel 1 Yellow	K	Channel 15 Yellow
10	Channel 7 Green	L	Channel 7 Yellow
11	Channel 14 Yellow	M	Channel 3 Green
12	Channel 3 Yellow	N	Channel 16 Yellow
13	Channel 9 Green	P	Channel 17 Yellow
14	Channel 17 Green	R	Channel 10 Green
15	Channel 11 Yellow	S	Channel 11 Green
16	Channel 9 Yellow	T	Channel 18 Yellow
17	Channel 18 Green	U	Channel 10 Yellow
--		--	
18	Channel 12 Yellow	V	Channel 12 Green
19	Channel 17 Red	W	Channel 18 Red
20	Chassis Ground	X	Not Assigned
21	AC-	Y	DC Common
22	Watchdog Timer	Z	External Test Reset
23	+24VDC	AA	+24VDC
24	Tied to Pin 25	BB	Stop Time (Output)
25	Tied to Pin 24	CC	Not Assigned
26	Not Assigned	DD	Not Assigned
27	Relay Output, Side #3, N.O.	EE	Relay Output, Side #2, Common
28	Relay Output, Side #1, N.C.	FF	AC+

-- Slotted for keying between Pins 17/U and 18/V

TS-35

CONFLICT PROGRAM CARD PIN ASSIGNMENTS

Pin #	Function (Back Side)	Pin #	Function (Component Side)
1	Channel 2 Green	A	Channel 1 Green
2	Channel 3 Green	B	Channel 2 Green
3	Channel 4 Green	C	Channel 3 Green
4	Channel 5 Green	D	Channel 4 Green
5	Channel 6 Green	E	Channel 5 Green
6	Channel 7 Green	F	Channel 6 Green
7	Channel 8 Green	H	Channel 7 Green
8	Channel 9 Green	J	Channel 8 Green
9	Channel 10 Green	K	Channel 9 Green
10	Channel 11 Green	L	Channel 10 Green
11	Channel 12 Green	M	Channel 11 Green
12	Channel 13 Green	N	Channel 12 Green
13	Channel 14 Green	P	Channel 13 Green
14	Channel 15 Green	R	Channel 14 Green
15	Channel 16 Green	S	Channel 15 Green
16	N/C	T	PC AJAR
17	Channel 1 Yellow	U	Channel 9 Yellow
18	Channel 2 Yellow	V	Channel 10 Yellow
19	Channel 3 Yellow	W	Channel 11 Yellow
20	Channel 4 Yellow	X	Channel 12 Yellow
21	Channel 5 Yellow	Y	Channel 13 Yellow
22	Channel 6 Yellow	Z	Channel 14 Yellow
23	Channel 7 Yellow	AA	Channel 15 Yellow
24	Channel 8 Yellow	BB	Channel 16 Yellow
--		--	
25	Channel 17 Green	CC	Channel 17 Yellow
26	Channel 18 Green	DD	Channel 18 Yellow
27	Channel 16 Green	EE	PC AJAR (Program Card)
28	Yellow Inhibit Common	FF	Channel 17 Green

-- Slotted for keying between Pins 24/BB and 25/CC

TS-36

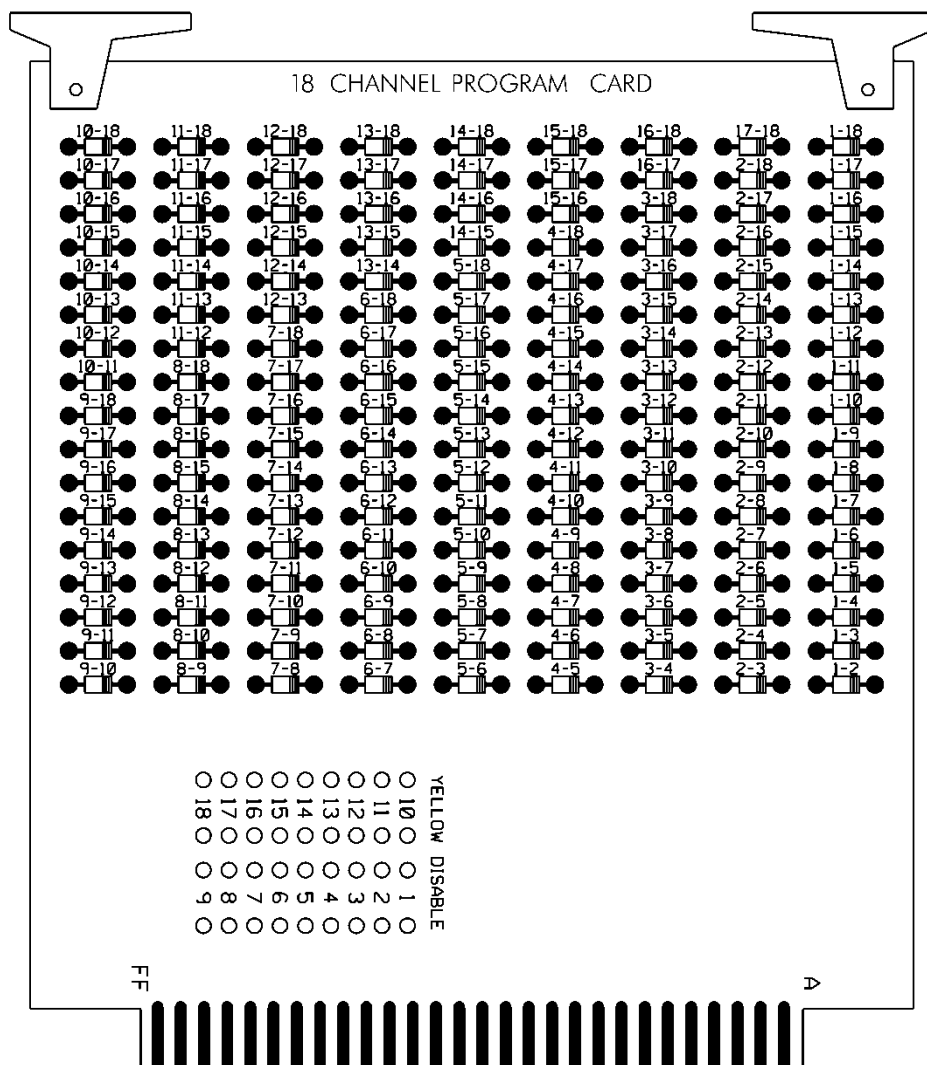

E. Preemption and Sign Control Box

Provide preemption and sign control box to operate in a Model 332 and Model 336S cabinet. Provide hardware to mount the box to the cage of the cabinet to ensure the front side is facing the opposite side of the cabinet. Furnish the material of the box from a durable finished metallic or thermoplastic case. Ensure the size of the box is not greater than 7(l) x 5(w) x 5(d) inches. Ensure that no modification is necessary to mount the box on the cabinet cage.

Provide the following components in the preemption and sign control box: relays, fuses, terminal blocks, MOVs, resistor, RC network, lamp, and push button switch.

Provide UL Listed or Recognized relay K1 as a DPDT enclosed relay (120 VAC, 60 Hz coil) with an 8-pin octal-style plug and associated octal base. Provide contact material made of AgCdO with a 10 amp, 240 VAC rating. Ensure the relay has a specified pickup voltage of 102 VAC.

Provide relay SSR1 as a Triac SPST normally open solid state relay that is rated for 120 VAC input and zero-crossing (resistive load) 25 amp @ 120 VAC output. Ensure the relay turns on at 90 Vrms within 10 ms and turns off at 10 Vrms within 40 ms. Ensure the relay has physical

TS-37

characteristics as shown in the wiring detail in Figure 1. Provide 4 terminal screws with saddle clamps.

Provide fuses F1 and F2 as a UL Listed ¼" x 1-1/4" glass tube rated at 250 volts with a 10kA interrupting rating. Ensure F1 non-delay (fast-acting) and F2 slow-blow (time-delay) fuses have a maximum opening times of 60 minutes and 120 seconds for currents of 135 and 200 percent of the ampere rating, respectively. Ensure F2 slow-blow (time-delay) fuses have a minimum opening times of 12 seconds at 200 percent of the ampere rating. Provide fuse holders that are UL Recognized panel-mounted holders rated 250V, 15 ampere minimum with bayonet-type knobs which accept ¼" x 1-1/4" glass tube fuses.

Provide terminal blocks that are rated for 300V and are made of electrical grade thermoplastic or thermosetting plastic. Ensure each terminal block is of closed back design and has recessed-screw terminals with molded barriers between terminals. Ensure each terminal block is labeled with a block designation. Ensure each terminal is labeled with the function and a number.

Provide 3/4-inch diameter radial lead UL-recognized metal oxide varistors (MOVs) that have electrical performance as outlined below.

PROPERTIES OF MOV SURGE PROTECTOR	
Maximum Continuous Applied Voltage at 185° F	150 VAC (RMS) 200 VDC
Maximum Peak 8x20µs Current at 185° F	6500 A
Maximum Energy Rating at 185° F	80 J
Voltage Range 1 mA DC Test at 77° F	212-268 V
Max. Clamping Voltage 8x20µs, 100A at 77° F	395 V
Typical Capacitance (1 MHz) at 77° F	1600 pF

Provide resistor R1 as a 2K ohm, 12 watt, wirewound resistor with tinned terminals and attaching leads. Ensure the resistor is spaced apart from surrounding wires.

Provide a LED or incandescent lamp that has a voltage rating of 120 VAC with a minimum life rating at 50,000 hours.

Wire the preemption and sign control box as shown in Figure 1.

RAILROAD PREEMPTION WIRING DETAIL

(wire as shown below)

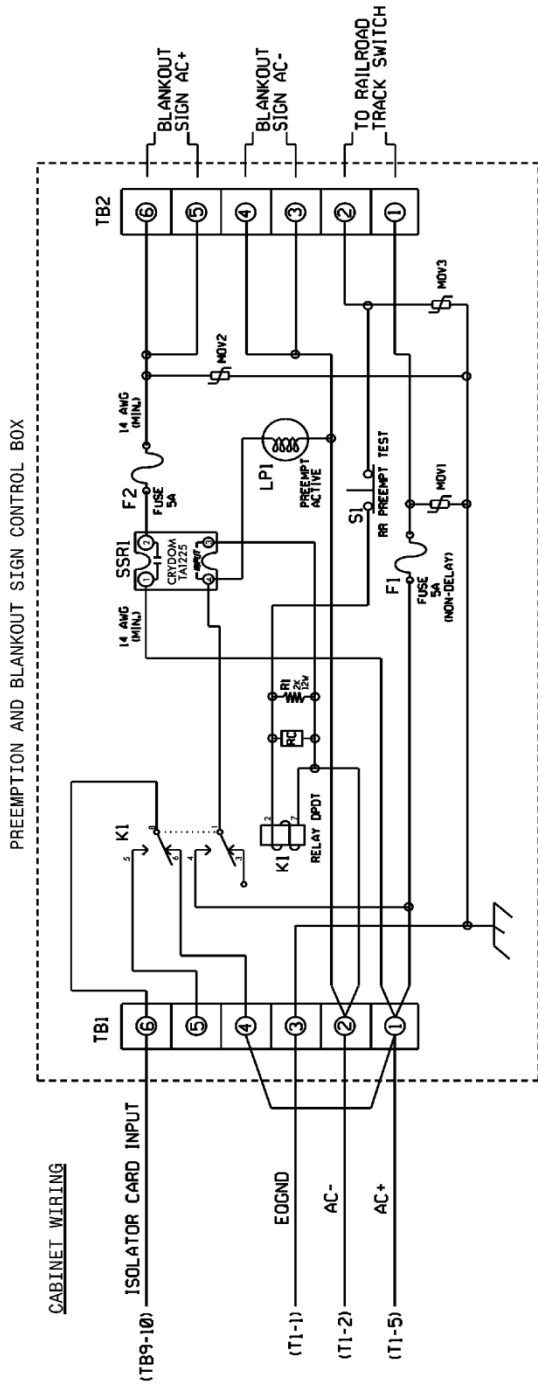

NOTES

1. RELAY K1 IS SHOWN IN THE ENERGIZED (PREEMPT NO1 ACTIVE) NORMAL OPERATION STATE.
2. AC ISOLATOR CARD SHALL ACTIVATE PREEMPTION UPON REMOVAL OF AC+ FROM INPUT (AS SHOWN ABOVE). THIS IS ACCOMPLISHED BY SETTING TYPE 252 AC ISOLATOR CARD TO INVERTED OPERATION.

FRONT VIEW

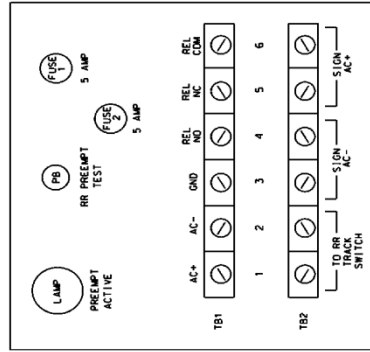

Figure 1

TS-39

3.7. MATERIALS – NEMA TS-1 CABINETS

A. NEMA TS-1 Cabinet Physical Requirements:

Furnish unpainted, natural, aluminum cabinet shells. Ensure that all non-aluminum hardware on the cabinet is stainless steel or a Department approved non-corrosive alternate. Provide a roof with a slope from front to back at a minimum ratio of 1-inch drop per 2 feet. Ensure that each exterior cabinet plane surface is constructed of a single sheet of aluminum and is seamless.

Provide a handle and three point latching mechanism designed to be disassembled using hand tools. Provide a shaft connecting the latching plate to the door handle by passing through the door within a bushing, bearing, or equivalent device. Provide a latching plate at least 3/16 inch thick and that mates securely with the lock bolt. Provide a lock bolt with a flat end (no bevel) and that has at least 1/4 inch of length in contact with the latching plate.

Ensure that the handle and lock are positioned so that the lock does not lie in the path of the rotating handle as the door is unlatched and that the handle points down in the latched position.

Provide a cabinet that is neat in appearance. Provide continuous welds made from the inside wherever possible. On the exterior, provide smooth and flush joints. Ensure there are no superfluous holes in the outside of the cabinet. Ensure that no screws, bolts, nuts or rivets protrude to the outside of the cabinet shell. Ensure cabinet surface is smooth and free of blemishes and discoloration.

Provide a main door opening that encompasses the full frontal area of the cabinet shell exclusive of the area reserved for plenums and flanges. Provide a rear door in base-mounted cabinets, unless otherwise specified. Ensure that the rear door complies with all requirements for the front door, except as follows:

- Hinge rear door on the left side as viewed from the rear of the cabinet shell facing the door.
- No police compartment is required on a rear door.

Ensure that the cabinet shell is sturdy and does not exhibit noticeable flexing, bending or distortion under normal conditions except that a minor amount of flexing is permitted in the main door and rear door only when the cabinet is open. In such case, the flexing must not result in permanent deformation of the door or damage to components mounted on the door. Ensure that pedestal-mounted cabinets have sufficient framing around the slipfitter attachment so that no noticeable flexing will occur at or about this point.

Ensure that the cabinet is large enough to accommodate all of the required equipment, specified future equipment, and wiring within the cabinet to provide sufficient room for servicing. Provide ample space in the bottom of the cabinet for the entrance and forming of all necessary wires and cables without interference with the operation, viewing, and servicing of the equipment. Ensure that the size of the cabinet permits all required and specified future equipment to be mounted in the upright position with sufficient space around it to provide adequate ventilation. Ensure at least 2 inches of clearance is provided around all vents and fans to insure proper air circulation. Ensure the interior size of the cabinets is at least:

Pole- and pedestal-mounted controller cabinets:	4.98 ft ³
Base-mounted controller cabinets:	11.6 ft ³
Pole- and pedestal-mounted on-street master cabinets:	3.5 ft ³
Base-mounted on-street master cabinets:	7.52 ft ³

TS-40

If specified on the bid list or the plans, controller cabinets as small as 3.3 ft³ may be provided for pole- and pedestal-mounted cabinets provided all other requirements are satisfied. Unless otherwise noted, ensure that cabinets do not exceed the following dimensions:

Maximum Outside Dimensions

Type of Cabinet	Height	Width	Depth
Pole-mounted	52 inches	30 inches	22 inches
Pedestal-mounted	36 inches	30 inches	22 inches
Base-mounted	None	None	None

Provide at least 2 sturdy shelves having an unobstructed depth of at least 13 inches. Ensure top shelf is at least 12 inches below the top of the door opening. Secure any card rack to the walls or shelves. Ensure equipment and components mounted on the cabinet walls require no more than the use of a screwdriver to accomplish their easy removal for servicing. Ensure shelf-mounted units are placed in their proper positions on the shelves without having to twist or turn them during the placement process.

Provide a minimum 12 x 14 inch plastic envelope or container located in the cabinet so that it is convenient for service personnel. Furnish two sets of non-fading cabinet wiring diagrams and schematics in a paper envelope or container and placed in the plastic envelope or container.

Provide a roof with a shield that prevents water from dripping into the cabinet. Equip the roof with a thermostatically controlled exhaust fan and suitably screened exhaust vents that will permit the flow of air for which the fan is rated. Ensure that base-mounted cabinets have a fan rated for at least 12 gal./s and pole- and pedestal-mounted cabinets have a fan rated for at least 6 gal./s. Ensure that the fan does not protrude to the outside of the cabinet and that it is mounted in such a way that it can be easily removed for servicing. Fusing the fan is not required. Ensure that the roof assembly is formed in such a way that it facilitates air exhaust from the fan.

Provide an additional vent or vents at or near the bottom to permit the intake of air. Ensure that the size of the vents permit the flow of air corresponding to the rated flow of the fan. Ensure that the vents are not smaller than 29.45 in². Equip the vents with standard-size replaceable fiberglass filters. Ensure that the vents do not permit the entrance of rain or snow.

Furnish a fluorescent fixture as required by NEMA TS-2 Specifications with a second lighting fixture mounted under the bottom shelf to light the terminals. Ensure that the second fixture is a fluorescent lighting fixture that complies with NEMA TS-2 Specifications or is a flexible gooseneck fixture containing a protected incandescent reflector bulb of a least 25 Watts. Furnish all bulbs. Ensure that the lamps are door switch actuated.

Provide the cabinet with an adjustable thermostat located in the upper portion of the inside the roof and connected to control the fan. Ensure that it is manually adjustable within the range of at least 78 to 170 degrees F with a calibrated scale. Ensure that the thermostat has contacts rated for use with the fan. Ensure that the thermostat turns the fan on at the set temperature and turns it off when the temperature is 4.5 degrees F below the set temperature.

Provide sufficient electrical and electronic noise suppression in the cabinet to enable all equipment in it to function properly. Ensure cabinet is equipped with one or more radio interference filters connected between the stages of the power line surge protector. Ensure filter(s) minimize interference generated in the cabinet in both the broadcast and aircraft frequencies. Ensure filter(s)

TS-41

provide attenuation of at least 50 decibels over a frequency range of 200 kilohertz to 75 megahertz. Provide filters that are hermetically sealed in metal cases and are insulated. Ensure filter is rated at least at the rated current of the main circuit breaker, 125-volt, 60 Hertz.

B. NEMA TS-1 Cabinet Electrical Requirements:

Provide duplex receptacle in the cabinet located conveniently for service personnel and in such a position that no electrical hazard will be presented to such personnel when using the receptacle. Ensure that the receptacle is a 3-wire ground fault interrupt type that will also accept a standard 2-prong, non-grounding plug. Ensure that the receptacle is reserved for the use of service personnel. Ensure normal control cabinet equipment is not connected to the receptacle.

Provide the cabinet with a NEMA standard circuit breaker box having at least two circuit breakers. Alternatively, provide circuit breakers that are installed in such a way that personnel servicing the cabinet, including the rear of the back panel, cannot inadvertently be exposed to a hazard. Ensure that a terminal block connected to the circuit breakers accommodates service wire as large as Number 6 AWG. Ensure that these circuit breakers are in addition to any fuses that are a part of the individual control equipment components. Provide a clear plastic guard or the equivalent to prevent incidental contact and shock hazard that protects exposed 120-volt AC terminals on the power panel.

Provide a cabinet with a ground bus having at least 20 terminals. Ensure that the bus is attached and electrically bonded to the wall of the cabinet and located conveniently to the traffic signal load circuits. Provide terminals to accommodate Number 10, 12, and 14 AWG conductors. Ensure that at least one terminal on each end is grounded and accommodates a Number 4 AWG conductor.

Provide a cabinet with an AC Neutral bus having at least 24 terminals. Ensure bus is isolated electrically from the cabinet ground. Provide terminals to accommodate Number 10, 12, and 14 AWG conductors. Ensure bus bar is conveniently located near the traffic signal load circuits.

Provide surge suppression in the cabinet and ensure that all devices operate over the temperature range of -40 to 185 degrees F.

Provide a loop surge suppresser for each set of loop terminals in the cabinet. Use terminal mount or stud mount devices for terminating the loop surge suppresser. Ensure that the device can withstand a minimum of 25 peak surge current occurrences at 100A in differential and common modes for a 10x700 microsecond waveform. Ensure that the maximum breakover voltage is 170V and the maximum on state clamping voltage is 30V. Provide a maximum response time less than 5 nanoseconds and an off state leakage current less than 10 μ A with a nominal capacitance less than 220pf for both differential and common modes.

Provide surge suppression on each communications line entering or leaving a cabinet. Ensure that the communications surge suppresser can withstand at least 80 occurrences of an 8x20 microsecond waveform at 2000A, or a 10x700 microsecond waveform at 400A. Provide a maximum clamping voltage suited to the equipment protected. Provide a maximum response time less than 1 nanosecond with a nominal capacitance less than 1500pf and a series resistance less than 15 Ω .

Ensure that no direct inter-equipment connection is made. Ensure that all equipment is connected to other items of equipment at the cabinet terminal blocks.

Provide the capability for each item of equipment from the cabinet to be removed without disconnecting individual wires. Provide the equipment with suitable MS-type or other multi-pin connectors, or mount in card racks that provide for automatic connection of the card when it is

TS-42

inserted in the rack. Ensure that connectors for the controller A, B and C harnesses, for shelf-mounted detectors and for conflict monitors are metal and separately bonded to the chassis.

Ensure that functionally equivalent equipment is electrically and mechanically interchangeable.

Ensure that all equipment and circuit cards are designed or keyed so that it is physically impossible to connect the unit to the wrong connector or insert it into an incorrect slot. Equip the cabinet with terminal blocks (strips) for the termination of all field conductors and all internal wires and harness conductors. Ensure that all wires are terminated at the terminals. Provide field terminals that are readily accessible without the removal of equipment and located conveniently to the wires, cables and harnesses. Ensure that each terminal block is of electrical grade thermoplastic or thermosetting plastic and each terminal block is a closed back design and has recessed-screw terminals with molded barriers between the terminals.

Ensure that each terminal of a terminal block consists of two terminal screws with a removable shorting bar between them. However, if the terminal block is part of a fabricated panel, each terminal may consist of a single terminal screw with a feed-through binding post to which conductors are soldered behind the panel. Exception: Terminal blocks used for field wiring connections are not required to have removable shorting bars unless required by a specific manufacturer's design. Ensure that each terminal block is labeled with a block designation and each terminal is labeled with a number. Ensure that all terminal functions are also labeled on the back panel or terminal blocks. Provide labels that are visible when the terminal block is fully wired. Ensure that the labels are shown on the cabinet wiring diagrams. Ensure that no terminals are closer than 4 inches to the bottom of the cabinet and provide those in base-mounted cabinets at least 6 inches from the bottom. Ensure that terminals serving similar functions are grouped together. Ensure that no terminals are located on the under side of shelves or at other places where they are not readily visible and accessible or where they may be a hazard to personnel who might inadvertently touch them. Provide police panel, if required, with an enclosure over the terminals of its components to prevent hazard to personnel. Cardboard and other types of flexible covers are not acceptable.

Ensure all equipment in the cabinet is connected to the cabinet, to the other items of equipment, and to the field circuits at the cabinet terminal blocks by means of neatly trained harnesses.

Provide harnesses in the cabinet for non-permanently mounted equipment that are long enough to allow the equipment to be relocated in an upright position to the roof of the cabinet or to be located to the ground 12 inches below cabinet level. Provide a secondary ground conductor of sufficient size to safely carry any fault current for harnesses that supply power or an AC+ input greater than 24 volts. Ensure that all harnesses are neatly dressed along the cabinet walls either parallel to or perpendicular to the floor. Ensure that they do not run diagonally. Ensure that the harness, which connects the components on the door to the remainder of the cabinet does not touch the doorjamb in any door position, including fully open.

Ensure that each conductor, including unused conductors, within or entering the cabinet is connected to a terminal. Ensure that no more than two conductors are connected to any single terminal screw with the following exception. Multiple conductors may be attached to a terminal used to distribute AC and DC power functions (AC+, AC-, Earth Ground, 24VDC, Logic Ground, etc.) or similar multi-use signals under the following conditions:

- it is unlikely that the conductors attached to such terminals will be removed by the cabinet user and,

TS-43

- there exists at least one terminal for each of the functions that has two or fewer conductors connected to it that is available for customer use.

This exception does not alter other requirements in these specifications that define the required number of terminals for power or other specific circuits. This provision does not apply to terminals on the load side of the load switches.

Ensure that each conductor has a crimped spade lug when connected to a terminal screw. Terminations to the back panel may be soldered. Connections such as quick connectors and barrel connectors are not acceptable. No in-line splices are permitted in any conductor.

Ensure outgoing circuits are of the same polarity as the line side of the AC supply. Ensure that the common return is of the same polarity as the grounded side of the AC supply.

Ensure all wiring is formed into neatly packaged and neatly dressed harnesses and laced, braided or tied with nylon tie wraps at closely spaced intervals. Where wires, cables or harnesses must be attached to the cabinet walls or door for support or to prevent undue wear or flexing, ensure attachment is made using nylon tie straps or metal clamps with rubber or neoprene insulators. Ensure that these attachment devices are screwed to the cabinet. Stick-on clamps or straps are not permitted.

Ensure that all field wiring and all internal conductors that are likely to be disconnected from time to time are tagged with non-fading, permanent sleeve labels at the ends of the conductors at the terminals. Ensure that sleeve labels are shrunk tightly to grip the conductors. Alternatively, hot stamp labels on the insulation of internal conductors at intervals of no greater than 4 inches. Ensure that all jumpers are wire conductors or metal plates. Using printed circuit back panels or back panels with wire tracks on boards are not permitted.

Provide 3 terminals (2 for loop conductors and 1 for shield) for each loop shown on the plans or required by the bid list. As a minimum, ensure cabinet provides sufficient terminals for 4 loops and detectors in Type 2 cabinets, 8 loops and detectors in Type 4 cabinets, and 16 loops and detectors in Type 8 cabinets. Provide a loop detector surge protector connected to each detector loop input.

Furnish the cabinet with a neatly labeled test switch panel mounted on the inside of the cabinet door. Ensure that the panel contains the following components that are connected to provide the functions indicated. Unless otherwise required, provide switches that are heavy-duty toggle switches.

- 1) **Detector Circuit Test Switch:** Ensure each detector circuit test switch is a three-position (on-normal-momentary on) switch. Ensure each switch is connected to the controller's or communications unit's detector input and in parallel with its associated detector's output so service personnel can place both momentary and constant calls on the device to be actuated. When in the normal position (center position), ensure switch has no effect on the device to be actuated. In all cases, the detector is to remain connected to the device to be actuated. Provide a detector circuit test switch for each vehicle detector input connected to the controller and each pedestrian detector input to the controller regardless of how many of the controller's phases are in use. In addition, provide detector circuit test switches connected to the system detector inputs of the communications unit if required by the plans or the bid list. As a minimum, provide the following numbers of switches:

TS-44

Type of Cabinet	Vehicle	Pedestrian
	Detector Switches	Detector Switches
Type 2 cabinet	2	2
Type 4 cabinet	4	4
Type 8 cabinet	8	4

- 2) **Technician Flash Switch:** Provide the test switch panel with a toggle switch for switching the intersection operation between normal stop-and-go (AUTO) operation and flashing operation. Protect this switch against accidental activation by a flip-up switch guard that does not affect switch position when closed.
- 3) **Controller Power Switch:** Provide a test switch panel that contains a toggle switch connected to remove power from the controller and all auxiliary equipment but ensure it does not interrupt power to the flasher. Ensure that this switch is protected against accidental activation by a flip-up switch guard that does not affect switch position when closed.
- 4) **Preemption Test Switches:** Provide a preemption test switch for each distinct preemption operation required by the plans or the bid list. Ensure that the switch is located on the inside of the door or on the left or right inside wall of the cabinet at an easily accessible location. Ensure that the switch is protected against accidental activation by a flip-up switch guard that does not affect switch position when closed.

Provide the cabinet with a police panel that is furnished with the indicated components connected:

- 1) **Police Panel Construction:** Provide a police panel with a door on it in the main door that is accessible when the main door is closed and will not allow water to enter the cabinet when the police door is open. Ensure that the police panel door is hinged on the right side as viewed facing it and has a lock that is keyed with two furnished keys and keyed to a standard police/fire call box key for each cabinet.
- 2) **Emergency Flash Switch:** Provide the police panel with a toggle switch for switching the intersection operation between normal stop-and-go (AUTO) operation and flashing operation.
- 3) **Signal Switch:** Provide the police panel with a toggle switch connected to permit power to be turned on and off to the field signal indicators. When in the off position, ensure that the power it removes is from the field signal indicators and that the controller and all equipment in the cabinet continue to operate normally.
- 4) **Automatic/Manual Switch:** Provide the police panel with a toggle switch connected to switch the intersection operation between normal stop-and-go operation (AUTO) and manual operation (MANUAL) using a hand control. Ensure that the manual control is implemented using only the Manual Control Enable and Interval Advance functions of the controller.
- 5) **Hand Control:** Provide a hand control with each cabinet for the police panel if specifically required by the plans or the bid list. Provide the hand control as a standard traffic signal manual control push-button connected on one end of a 10 feet coil cord with a 1/4 inch locking phone plug on the other end. Provide a locking phone jack in the police panel for this hand control to effect manual control of the intersection as described above. Ensure the plug and jack lock

TS-45

together so they will not disconnect even when the cord is stretched to its limit. Ensure police panel has room for storage of the hand control.

Provide the cabinet with one or as many as needed solid state flashers to operate the signal displays when the intersection is operated in the flashing mode. Provide the cabinet with a flasher socket for each flasher and make it part of the cabinet back panel. Ensure that the cabinet is wired so that it is possible to select either flashing red or flashing yellow for each signal circuit by switching a jumper plug on the back panel or by switching jumpers using simple hand tools. Ensure that disassembly of and access to the rear of the back panel is not required to effect a flash color change. Ensure that movement of no more than three jumpers is required to change the flash color for any signal circuit. Ensure that the cabinet is wired to effect the switch between normal stop-and-go operation and flashing operation. Provide the following flashing operation:

- Ensure that the controller controls the planned change from stop-and-go operation to flashing operation.
- Ensure that upon actuation of the emergency flash switch in the police panel or the technician flash switch in the test switch panel or upon command of the conflict monitor, the signal indicators are disconnected from the load switches and the appropriate signal indicators are connected to flashing power. Ensure all other signal indicators are dark. Ensure this change takes place immediately upon actuation regardless of the signal indicators being displayed.
- Regardless of the mode of entry into flashing operation, ensure that the return to normal stop-and-go operation occurs only when the controller begins to time the major street WALK interval (green interval if WALK is not used). Ensure that this is accomplished via the activation of the external start input.
- Ensure that the operation of the intersection controller is not affected when the technician flash switch or the communications unit initiates flashing operation, if any, and the controller continues to operate normally. Ensure that the controller stops timing when actuated by the emergency flash switch or the conflict monitor.

Furnish all cabinets, except pretimed cabinets, with optical isolation circuits connected between the pedestrian push-buttons and the pedestrian detector inputs of the controllers and the two-pulse pedestrian detector logic units, if any. Ensure all electronic components for the isolation circuits are contained on a circuit board that can be easily disconnected from its receptacle. Provide isolation circuits for the following number of pedestrian detector circuits:

Type 2 cabinet:	2
Type 4 cabinet:	4
Type 8 cabinet:	4

Ensure that the voltage present at the pedestrian push-buttons does not exceed 24 volts.

C. NEMA TS-1 Conflict Monitors:

Furnish NEMA TS-1 conflict monitor with programming card. Ensure that the absence of the programming card will cause the conflict monitor to trigger, and remain in the triggered state until reset.

TS-46

Provide a conflict monitor that recognizes the following faults in addition to those specified by NEMA TS-1 Section 6. Ensure that the conflict monitor will trigger as required by the NEMA Specifications:

- Yellow indication missing or shorter than 2.7 seconds (with ± 0.1 second accuracy);
- Walk indication without green vehicle indication on same channel;
- Dual Indications on the same channel.

Ensure that the tests for short and missing yellows and for dual indications be turned on or off per channel. Ensure that the test for walk without green be selectable for each unit. If one of the additional optional fault tests are enabled and an associated fault is detected, ensure that the conflict monitor remains in the triggered state until the unit is reset unless otherwise specified.

When the conflict monitor is triggered, provide a visual indication of the type of event that triggered the unit. Ensure that these indications and the status of each channel be retained until the conflict monitor is reset.

Ensure that the conflict monitor allows user selected latching of the CVM, 24V I, and 24V II inputs. When the conflict monitor is set for latching operation and one of these events is triggered, ensure that the monitor is reset before returning to normal operation.

Provide nonvolatile memory in the conflict monitor that retains a log of events containing the failure type, channel status, date, time for the nine most recent faults, and the date and time of the ten most recent power failures at a minimum. Ensure that the conflict monitor outputs the event log on request to a printer and uploads the event log on request to a Department-furnished personal computer via the RS-232C serial port. Provide the RS-232C serial port mounted on the front.

Provide a conflict monitor with the number of channels required by the plans or bid list. Where required by the plans or bid list, ensure that the conflict monitor is supplied with a wiring harness set. Ensure that the harness is fitted with the proper connector and the harness is 10 feet in length.

3.8. MATERIALS – NEMA TS-2 TYPE 1 CABINETS

A. NEMA TS-2 Type 1 Cabinets General:

Comply with the *NEMA Standards Publication TS-2* (NEMA TS-2) except as otherwise stated herein.

Furnish unpainted, natural, aluminum cabinet shells that comply with Section 7 of NEMA TS-2. Ensure all non-aluminum hardware on the cabinet is stainless steel or a Department approved non-corrosive alternate. Provide a roof with a slope from front to back at a minimum ratio of 1 inch drop per 2 feet. Ensure that each exterior cabinet plane surface is constructed of a single sheet of aluminum and is seamless.

Ensure all components are arranged for easy access during servicing. When modular in construction, provide guides and positive connection devices to insure proper pin alignment and connection.

Provide a moisture resistant coating on all circuit boards.

B. NEMA TS-2 Type 1 Cabinet Physical Requirements:

Provide a handle and three point latching mechanism designed to be disassembled using hand tools. Provide a shaft connecting the latching plate to the door handle by passing through the door

TS-47

within a bushing, bearing, or equivalent device. Provide a latching plate at least 3/16 inch thick and that mates securely with the lock bolt. Provide a lock bolt with a flat end (no bevel) and that has at least 1/4 inch of length in contact with the latching plate.

Ensure that the handle and lock are positioned so that the lock does not lie in the path of the rotating handle as the door is unlatched and that the handle points down in the latched position.

Provide continuous welds made from the inside wherever possible. On the exterior, provide smooth and flush joints. Ensure that no screws, bolts, or rivets protrude to outside of cabinet shell.

Provide a main door opening that encompasses the full frontal area of the cabinet shell exclusive of the area reserved for plenums and flanges. Provide a rear door in base-mounted cabinets, unless otherwise specified. Ensure that the rear door complies with all requirements for the front door, except as follows:

- * Hinge the rear door on the left side as viewed from the rear of the cabinet shell facing the door.
- * No police compartment is required on a rear door.

Ensure that the cabinet shell is sturdy and does not exhibit noticeable flexing, bending or distortion under normal conditions except that a minor amount of flexing is permitted in the main door and rear door only when the cabinet is open. In such case, the flexing must not result in permanent deformation of the door or damage to components mounted on the door. Ensure that pedestal-mounted cabinets have sufficient framing around the slipfitter attachment so that no noticeable flexing will occur at or about this point.

Provide NEMA TS-2, Type 1 cabinets with 2 shelves. Ensure top shelf has an unobstructed depth of at least 12 inches for base-mounted cabinets. Ensure top shelf has an unobstructed shelf depth of at least 13 inches for pole-mounted cabinets. Locate the top shelf at least 12 inches below the top of the door opening. Provide a lower shelf for mounting detector racks, its associated BIU, and other auxiliary equipment. Locate the lower shelf at least 10 inches below the top shelf, and provide at least 13 inches of unobstructed shelf depth. Secure card racks and associated BIU connector housings to the shelf by a removable means. Place the rack so that the front of the rack is not obscured by any object and so that backpanel terminals are not obscured even when the rack is fully utilized.

Provide a back panel hinged at the bottom for access during service.

Provide a minimum 12 x 14 inch plastic envelope or container located in the cabinet so that it is convenient for service personnel.

Furnish two sets of non-fading cabinet wiring diagrams and schematics in a paper envelope or container and placed in the plastic envelope or container.

Do not locate permanently mounted equipment in such a way that will restrict access to terminals.

C. NEMA TS-2 Type 1 Cabinet Electrical Requirements:

Provide a neutral that is not connected to the earth ground or the logic ground anywhere within the cabinet. Ensure the earth ground bus and the neutral ground bus each have ten compression type terminals each of which can accommodate wires ranging from number 14 through number 4.

TS-48

Provide surge suppression in the cabinet and ensure that all devices operate over the temperature range of -40 to 185 degrees F.

Provide a loop surge suppresser for each set of loop terminals in the cabinet. Use terminal mount or stud mount devices for terminating the loop surge suppresser. Ensure that the device can withstand a minimum of 25 peak surge current occurrences at 100A in differential and common modes for a 10x700 microsecond waveform. Ensure that the maximum breakover voltage is 170V and the maximum on-state clamping voltage is 30V. Provide a maximum response time less than 5 nanoseconds and an off-state leakage current less than 10 μ A. Ensure that a nominal capacitance less than 220pf for both differential and common modes.

Provide surge suppression on each communications line entering or leaving a cabinet. Ensure that the communications surge suppresser can withstand at least 80 occurrences of an 8x20 microsecond waveform at 2000A, or a 10x700 microsecond waveform at 400A. Provide a maximum clamping voltage suited to the equipment protected. Provide a maximum response time less than 1 nanosecond with a nominal capacitance less than 1500pf and a series resistance less than 15 Ω .

Furnish a fluorescent fixture as required by NEMA TS-2 Specifications with a second lighting fixture mounted under the bottom shelf to light the terminals. Ensure that the second fixture is a fluorescent lighting fixture that complies with NEMA TS-2 Specifications or is a flexible gooseneck fixture containing a protected incandescent reflector bulb of at least 25 Watts. Furnish all bulbs. Ensure that the lamps are door switch actuated.

Provide connector type harnesses for all equipment installed in the cabinet, including detector racks. Furnish a harness with connectors to adapt the NEMA TS-2, Type 2 controller "A" connector to the NEMA TS-2, Type 1 "A" connector furnished with the cabinet assembly.

Tag all conductors that are likely to be disconnected from time to time with non-fading, permanent sleeve labels at the ends of the conductors.

In cabinets that are not base mounted, have no terminals closer than 4 inches to the bottom of the cabinet.

Fasten all wiring and harness supports to the cabinet with screws or other removable mechanical means. Do not use adhesives.

Provide harnesses in the cabinet for non-permanently mounted equipment that are long enough to allow the equipment to be relocated in an upright position to the roof of the cabinet or to be located to the ground 1 foot below cabinet level.

Do not locate terminals on the underside of shelves or at other places where they are not readily visible and accessible, or where they may be a hazard to personnel. Provide a clear plastic guard for exposed 120 volt AC terminals on the power panel and the rear of terminal facilities accessible from the rear door.

Provide compression type earth grounds with 10 position terminal buses sized for four Number 14 AWG wires. Provide screw-type terminals for signal feed, detector lead-in, NEMA I/Os, backpanels, and interconnect terminals. Provide screw terminals for all other devices not defined by NEMA TS-2 Specifications. Ensure that wiring by the manufacturer is terminated either on double terminal strips with crimped-on lugs or soldered to rear terminals.

Ensure that upon leaving any cabinet or malfunction management unit (MMU) initiated flashing operation, the controller reverts to its programmed start-up operation through the use of the START

TS-49

UP FLASH CALL feature. Do not require special controller software to implement the return from flash in the start up mode of operation. Wire one of the output relays of the MMU to apply a logic ground to the STOP TIME input for rings 1 and 2 when the MMU initiates flashing operation because of a sensed failure. Ensure that the MMU is interlocked within the cabinet control circuitry as to prevent normal signal operation with the MMU disconnected. Ensure that the 24Vdc supply to the load switches is disconnected when cabinet flashing operation is initialized. Provide a momentary pushbutton, or equivalent method, to apply 24Vdc to the load switches during cabinet flash for troubleshooting purposes.

Unless otherwise required, provide switches that are heavy-duty toggle switches.

Provide a technician panel mounted on the inside of the door with an EQUIPMENT POWER (ON/OFF) switch and an AUTO/FLASH switch. Ensure switches are protected against accidental activation by a flip-up switch guard that does not affect switch position when closed. Provide an EQUIPMENT POWER (ON/OFF) toggle switch that connects or disconnects protected equipment power to all devices in the cabinet and does not affect AC power to the flasher. Provide an AUTO/FLASH toggle switch which immediately places the intersection into flashing operation, disconnects the STOP TIME input generated by the MMU, and applies a logic ground to the LOCAL FLASH STATUS input of the MMU. When placed in the AUTO position, ensure that this switch causes the return of the intersection to normal operation at the programmed start up phases and intervals via the START-UP FLASH CALL feature of the controller unit. Provide a DETECTOR CHANNEL CALL three position detector test switch (on, normal, momentary on) installed for every detector channel in the detector racks. Provide four pedestrian detector test switches (on normal, momentary on) to the 4 pedestrian detector inputs of BIU no. 1. The switches may be installed on the door or on the non-door hinge side of the cabinet at the front of the cabinet.

Provide a police compartment constructed such that neither water nor dust will enter the interior of the cabinet through the police compartment, even when the police compartment door is open. Provide a rigid enclosure over the terminals of its components. Do not use flexible guards. Provide a SIGNAL POWER (ON/OFF) switch, an AUTO/FLASH switch, and an AUTO/MANUAL switch. Provide a locking jack for an optional manual push-button. Provide a SIGNAL POWER (ON/OFF) toggle switch which, when in the "OFF" position, disconnects AC power to the field terminals, applies logic ground to the LOCAL FLASH STATUS input of the MMU, and disconnects the STOP TIME input generated by the MMU. Ensure that a means to prevent recognition of red failure by the malfunction management unit is used and the switch does not affect power to equipment in the cabinet. When the SIGNAL POWER switch is switched to the "ON" position, ensure controller reverts to the programmed start-up phases and intervals via the START-UP FLASH CALL feature of the controller unit. Provide an AUTO/FLASH toggle switch that immediately places the intersection into flashing operation, and applies logic ground to the MMU LOCAL FLASH STATUS input. When placed in the AUTO position, ensure this switch allows the return of the intersection to normal operation at the programmed start-up phases and intervals via THE START-UP FLASH CALL feature of the controller unit. Provide an AUTO/MANUAL toggle switch that selects between normal operation (in the AUTO position) and manually controlled operation (in the MANUAL position). When in the MANUAL position, ensure that a logic ground is applied to the Manual Control Enable input of the controller. Ensure that only when a logic ground signal is applied to Manual Control Enable, the optional manual push-button can be used to advance the phases by applying and removing a logic ground signal to the Interval Advance input.

TS-50

Provide one flash transfer relay and flasher for each corresponding socket. Provide 2 spare terminals for each flasher circuit output. Provide 1 MMU and 1 cabinet DC power supply (shelf mounted) with all necessary harnesses wired to the appropriate cabinet/back panel termination points. Terminate unused MMU inputs. Provide BIUs with sockets and terminal facilities. BIUs 3 and 4 may be mounted in a rack separate from the back panel.

Provide a minimum of 2 sets of loop terminals and a single earth ground terminal between the 2 sets of loop wire terminals for each slot in each detector rack provided.

In cabinets with less than 16 loadbay positions, provide flash transfer relay circuits for load switches used to implement pedestrian signals that are brought out to separate terminals but not connected for flashing operation when pedestrian signals are assigned to the load switch channel. Ensure that the flash circuit inputs and outputs are available for easy connection to allow conversion of a pedestrian movement load switch for use as an overlap (vehicle phase) movement load switch. Provide a reserved flash transfer relay circuit for four vehicle movements and all necessary flash transfer relay input and output wiring and flash circuit wiring that can be made available at each pedestrian load switch position.

Comply with the applicable tables for the type of cabinet furnished:

TS-51

TS-2 Type 1 Cabinet Configurations

CABINET CONFIGURATION	LOAD SWITCH SOCKETS	FLASH RELAY SOCKETS	FLASHER SOCKETS	BIU'S REQUIRED (BACK PANEL/ DETECTOR)	DETECTOR RACK TYPE/ QUANTITY	TS-2 CABINET TYPE*
NC-1	4	2	1	1/1	1/1	4**
NC-2	8	4	1	1/1	2/1	5
NC-3	12	6	1	2/1	2/1	6
NC-3A	12	6	1	2/2	2/2	6
NC-3B	12	6	1	2/2	2/1 1/1	6
NC-4	12	6	1	†3/1	2/1	6
NC-4A	12	6	1	†3/2	2/2	6
NC-4B	12	6	1	†3/2	2/1 1/1	6
NC-5	12	6	1	‡4/1	2/1	6
NC-5A	12	6	1	‡4/2	2/2	6
NC-5B	12	6	1	‡4/2	2/1 1/1	6
NC-6	16	6	1	2/2	2/2	6
NC-6A	16	6	1	2/2	2/1 1/1	6
NC-7	16	6	1	†3/2	2/2	6
NC-7A	16	6	1	†3/2	2/1 1/1	6
NC-8	16	6	1	‡4/2	2/2	6
NC-8A	16	6	1	‡4/2	2/1 1/1	6

*See NEMA TS-2-1998, Table 7-1 for actual dimensions.

**Type 5 cabinet may be substituted for four position base mount cabinet.

† BIU 3 required along with BIU 1, BIU 2, and detector BIU(s).

‡ BIU 3 and BIU 4 required along with BIU 1, BIU 2, and detector BIU(s).

TS-52

8-Position Loadbay Cabinet Phase Assignments

PHASE /OL NUMBER	MALFUNCTION MANAGEMENT UNIT CHANNEL ASSIGNMENT	ASSIGNED TO LOAD SWITCH POSITION NUMBER	ASSIGNED TO FLASH RELAY NUMBER	ASSIGNED TO FLASHER CIRCUIT/	PROGRAM FLASH COLOR
1	1	1	1	1	R
2	2	2	1	2	Y
3	3	3	2	1	R
4	4	4	2	2	R
2 PED-O/LA †	5	5	†3	†1	D
4 PED O/L .B†	6	6	†3	†2	D
O/L C	7	7	4	1	R
O/L D	8	8	4	2	R

† Prepare this load switch position for the pedestrian movement indicated. Wire pedestrian signals to flash dark. Make flash circuitry for this load switch position available and accessible at a separate terminal to allow connection to the load switch and field terminal circuit for a vehicle movement at a later date if desired.

12-Position Loadbay Cabinet Phase Assignments

TS-53

PHASE /OL NUMBER	MALFUNCTION MANAGEMENT UNIT CHANNEL ASSIGNMENT	ASSIGNED TO LOAD SWITCH POSITION NUMBER	ASSIGNED TO FLASH RELAY NUMBER	ASSIGNED TO FLASHER CIRCUIT/ CIRCUIT/	PROGRAM FLASH COLOR
1	1	1	1	1	R
2	2	2	1	2	Y
3	3	3	2	1	R
4	4	4	2	2	R
5	5	5	3	2	R
6	6	6	3	1	Y
7	7	7	4	2	R
8	8	8	4	1	R
2 PED or O/L A†	9	9	†5	†1	D
4 PED or O/L B†	10	10	†5	†2	D
6 PED or O/C†	11	11	†6	†1	D
8 PED or O/L D†	12	12	†6	†2	D

† Prepare this load switch position for the pedestrian movement indicated. Wire pedestrian signals to flash dark. Make flash circuitry for this load switch position available and accessible at a separate terminal to allow connection to the load switch and field terminal circuit for a vehicle movement at a later date.

TS-54

16 Position Loadbay Cabinet Phase Assignments

PHASE /OL NUMBER	MALFUNCTION MANAGEMENT UNIT CHANNEL ASSIGNMENT	ASSIGNED TO LOAD SWITCH POSITION NUMBER	ASSIGNED TO FLASH RELAY NUMBER	ASSIGNED TO FLASHER CIRCUIT/	PROGRAM FLASH COLOR
1	1	1	1	1	R
2	2	2	1	2	Y
3	3	3	2	1	R
4	4	4	2	2	R
5	5	5	3	2	R
6	6	6	3	1	Y
7	7	7	4	2	R
8	8	8	4	1	R
2 PED	9	9	-	-	D
4 PED	10	10	-	-	D
6 PED	11	11	-	-	D
8 PED	12	12	-	-	D
O/L A	13	13	5	1	R
O/L B	14	14	5	2	R
O/L C	15	15	6	1	R
O/L D	16	16	6	2	R

Provide flasher circuits and flash transfer relay outputs and inputs that are brought out to terminals which provide a convenient means of changing flash color and flash circuit at each load switch position. Ensure that changing flash color of a given phase or overlap involves no more than moving three wires. Ensure that the selected phase or overlap flash color load switch output is easily movable to connect to the normally open flash transfer relay input assigned to the phase or overlap. Ensure that the common output of the flash transfer relay circuit assigned to the phase or overlap is easily movable to the selected field terminal (input) of the phase or overlap flash color. Ensure that the non-flashed load switch output is easily moved to provide power directly to the phase or overlap field terminal for that color.

In cabinets requiring a Type 1 detector rack, route to and terminate on a conveniently located terminal block on the back panel or elsewhere in the cabinet, the eight unused detector BIU Vehicle Call inputs. Tie the 8 unused detector BIU Detector Status inputs to the logic ground.

Provide detector racks and associated detector rack BIUs that are removable and replaceable from the cabinet either as a complete assembly or separately. Ensure that disconnection and reconnection of these units is through quick disconnect type connectors.

TS-55

3.9. MATERIALS – TYPE 170 DETECTOR SENSOR UNITS

Furnish detector sensor units that comply with Chapter 5 Section 1, “General Requirements,” and Chapter 5 Section 2, “Model 222 & 224 Loop Detector Sensor Unit Requirements,” of the CALTRANS “Transportation Electrical Equipment Specifications” dated March 12, 2009 with Erratum 1.

3.10. MATERIALS – NEMA TS-1 DETECTORS

Furnish NEMA TS-1 single-channel or multi-channel detectors.

Provide multi-channel detectors that sequentially scan each of its channels. Ensure that the multi-channel detectors can turn a channel off and disable its operation from the front panel.

Provide channels with a minimum of eight sensitivity levels.

Ensure detector units meet the requirements of NEMA TS-1 Specifications except as follows:

- Class 2 vehicle output is maintained for a minimum of 4 minutes, and
- Class 3 vehicle output is maintained for a minimum of 30 minutes, maximum 120 minutes.

Where required, furnish detectors equipped with required timing features. Provide a delay that is settable in one-second increments (maximum) over the range of zero to thirty seconds. Provide an extend that is settable in 1/4 second increments (maximum) over the range of 0 to 15 seconds. Provide detectors that can set both delay and extend timing for the same channel. If both timings are set, ensure the delay operates first. After the delay condition has been satisfied, ensure that the extend timer operates normally and that it is not necessary to satisfy the delay timing for an actuation arriving during the extend portion.

Ensure detectors register a permanent call during tuning operations, as a result of a loop fault, and when power is removed. Ensure detectors completely self-tune within 10 seconds after application of power or restoration of interrupted power and within 10 seconds after correction of a loop fault.

Provide detectors that monitor the loop for fault conditions on each channel. Upon detection of a fault condition, even if the condition is subsequently corrected, ensure the detectors provide an indication of the occurrence and maintain the indication until a manual reset. The fault conditions are:

- An open-circuited loop system;
- A short to ground; and
- A 25 percent reduction in inductance.

Ensure a two-channel detector operates normally with the same loop connected to both channels.

Provide lightning and surge protection that is incorporated into the design of the detector. Ensure that each channel operates properly when used with the loop detector surge protector.

In addition to NEMA TS-1 Specifications, ensure each channel is capable of tuning to and operating on any loop system inductance within the range of 50 to 2,000 μ h. Ensure that the channel will operate properly even on a loop system that has a single-point short to earth ground.

TS-56

Provide detectors with a durably finished nonferrous housing. Ensure that the removal of the housing can be accomplished by using simple hand tools. Ensure each printed circuit board has a moisture resistant coating and that the components are readily accessible with the housing removed.

Provide a wiring harness with a minimum length of 6 feet for each detector. Ensure each wire is permanently labeled, numbered, or color-coded.

3.11. MATERIALS – NEMA TS-2 DETECTOR CARDS AND RACKS

Furnish NEMA TS-2 multi-channel detector cards and racks.

Provide cards that sequentially scan each of its channels. Provide channels with a minimum of eight sensitivity levels.

On a multi-channel detector, ensure that it is possible to turn a channel off and disable its operation from the front panel.

Ensure that detector units meet the requirements of NEMA TS-2 Specifications except as follows:

- Class 2 vehicle output is maintained for a minimum of 4 minutes, and
- Class 3 vehicle output is maintained for a minimum of 30 minutes, maximum 120 minutes.

Where required, furnish detector cards equipped with required timing features. Provide a delay that is settable in one second increments (maximum) over the range of zero to thirty seconds. Provide an extend that is settable in 1/4 second increments (maximum) over the range of 0 to 15 seconds. Provide cards that can set both delay and extend timing for the same channel. If both timings are set, ensure that the delay operates first. After the delay condition has been satisfied, ensure that the extend timer operates normally and that it is not necessary to satisfy the delay timing for an actuation arriving during the extend portion.

Ensure that two-channel detector cards operate normally with the same loop connected to both channels.

Provide lightning and surge protection that is incorporated into the design of the detector. Ensure that each channel operates properly when used with the loop detector surge protector.

In addition to NEMA TS-2 Specifications, ensure that each channel is capable of tuning to and operating on any loop system inductance within the range of 50 to 2,000 μ h. Ensure that the channel will operate properly even on a loop system that has a single-point short to earth ground.

3.12. MATERIALS – TYPE 2070E CONTROLLERS

Furnish model 2070E controller units that conform to CALTRANS *Transportation Electrical Equipment Specifications* (TEES) (dated March 12, 2009, plus Errata 1 dated January 21, 2010 and Errata 2 dated December 5, 2014) except as required herein.

The Department will provide software at the beginning of the burning-in period. Contractor shall give 5 working days notice before needing software. Program software provided by the Department.

Provide model 2070E controllers with OS-9 release 1.3.1 or later with kernel edition #380 or later operating software and device drivers, composed of the unit chassis and at a minimum the following modules and assemblies:

- MODEL 2070-1E, CPU Module, Single Board, with 8Mb Datakey (blue in color)
- MODEL 2070-2E+, Field I/O Module (FI/O)

TS-57

- Note: Configure the Field I/O Module to disable both the External WDT Shunt/Toggle Switch and SP3 (SP3 active indicator is “off”)
- MODEL 2070-3B, Front Panel Module (FP), Display B (8x40)
- MODEL 2070-4A, Power Supply Module, 10 AMP
- MODEL 2070-7A, Async Serial Com Module (9-pin RS-232)

3.13. MATERIALS – TYPE 2070LX CONTROLLERS

Furnish model 2070LX controller units that conform to CALTRANS *Transportation Electrical Equipment Specifications* (TEES) (dated March 12, 2009, plus Errata 1 dated January 21, 2010 and Errata 2 dated December 5, 2014) except as required herein.

The Department will provide software at the beginning of the burning-in period. Contractor shall give 5 working days notice before needing software. Program software provided by the Department.

Provide model 2070LX controllers with Linux kernel 2.6.18 or higher and device drivers, composed of the unit chassis and at a minimum the following modules and assemblies:

- MODEL 2070-1C, CPU Module, Single Board, with 8Mb Datakey (blue in color)
- MODEL 2070-2E+, Field I/O Module (FI/O)
 - Note: Configure the Field I/O Module to disable both the External WDT Shunt/Toggle Switch and SP3 (SP3 active indicator is “off”)
- MODEL 2070-3B, Front Panel Module (FP), Display B (8x40)
- MODEL 2070-4A, Power Supply Module, 10 AMP

Provide a Board Support Package (BSP) to the state and to any specified applications software manufacturer when requested by the state to facilitate the porting of application software.

4. PUSH BUTTON INTEGRATED ACCESSIBLE PEDESTRIAN SIGNAL (APS)

4.1. DESCRIPTION

Furnish and install push button integrated accessible pedestrian signals that include pedestrian push button, push button locator tone, raised tactile arrow, audio and vibro-tactile walk indications, automatic volume adjustment, pedestrian information sign, and all necessary hardware. Furnish the R10-3e with appropriate arrow direction for the pedestrian information sign.

4.2. MATERIALS

Furnish material, equipment, and hardware under this section that is pre-approved on the ITS and Signals QPL.

Provide the accessible pedestrian signals with a 2-inch diameter pedestrian push button that contains a tactile arrow whose direction can be easily adjusted in the field. Ensure each push button actuates a sturdy, momentary, normally-open switch with a minimum rating of 20 million actuations. Include on the button, a raised tactile arrow having a high visual contrast with the remainder of the button face. Ensure the housing is weather-tight and fabricated from aluminum. Ensure the housing is suitable for mounting on wood and metal poles. Paint surfaces of the pedestrian push button housing in highway yellow, unless otherwise specified, with an electrostatically-applied, fused-

TS-58

polyester paint method. Ensure the thickness of the paint is a minimum of 2.5 mils. Provide the pedestrian information sign that is integral to the housing.

Ensure the accessible pedestrian signals can provide tones, sounds, and speech messages that are synchronized at an intersection. Provide a means for adjusting the base sound level for the tones, sounds, and speech messages. Ensure the tones, sounds, and speech messages will adjust automatically to the ambient noise level up to a maximum of 100 dBA. Provide the custom speech messages in both English and Spanish languages. Ensure you can program the accessible pedestrian signal by a means not readily accessible by unauthorized persons.

Ensure each push button provides a standard locator tone that is deactivated when the traffic signal is operating in the flash mode. Provide a user-programmable audible beaconing feature that is initiated by an extended push button press of one second or more. Ensure the audible beaconing feature increases the volume of the push button locator tone during the pedestrian change interval of the called pedestrian phase and operates in one of the following ways:

- A. The louder audible walk indication and louder locator tone comes from the far end of the crosswalk, as pedestrians cross the street,
- B. The louder locator tone comes from both ends of the crosswalk, or
- C. The louder locator tone comes from an additional speaker that is aimed at the center of the crosswalk and that is mounted on a pedestrian signal head.

Provide confirmation of the push button activation by an LED pilot light. Ensure the pilot light remains illuminated until the pedestrian's green or WALKING PERSON (symbolizing WALK) signal indication is displayed. Ensure each press of the pushbutton initiates a "wait" speech message during all intervals except the Walk interval.

Ensure you can select a percussive tone and custom speech message to sound during the "Walk" interval. Provide a push button that vibrates during the "Walk" interval. Ensure the "Walk" indications have the same duration as the illuminated pedestrian signals except when the signal is programmed to rest in the walk interval. When the pedestrian signal is programmed to rest in walk, ensure the "Walk" indication is limited to the first 7 seconds of the walk interval. The "Walk" indication shall be recalled by a button press during the walk interval provided that the crossing time remaining is greater than the pedestrian change interval. Ensure the "Walk" indications are deactivated when the traffic control signal is operating in a flashing mode. When audible "Walk" indications are selected as a percussive tone, ensure the tone repeats at 8 to 10 ticks per second and consists of multiple frequencies with a dominant component at 880 Hz.

Ensure the accessible pedestrian signals are weatherproof and suitable for operation in wet locations. Ensure proper operation over a temperature range of -30°F (-34°C) to 165°F (+74°C). Ensure all circuit boards have a moisture resistant coating. Ensure the equipment interfaces and operates properly in a Type-170E cabinet.

4.3.CONSTRUCTION METHODS

Comply with the requirements of Section 1705 of the *Standard Specifications*. Install in accordance with the manufacturer's recommendations.

Mount push button integrated accessible pedestrian signals in a tamperproof manner on wood and metal poles, signal pedestals, or pushbutton posts as indicated in the signal plans.

TS-59

Install each pushbutton so that the tactile arrow is pointed in the direction of travel and is aligned parallel to the direction of travel on the associated crosswalk.

Ensure pushbuttons are separated by a distance of at least 10 feet such that they clearly indicate which crosswalk has the WALK indication. Where there are constraints on a particular corner that make it impractical to provide the 10 feet of separation between the two pushbuttons, the pushbuttons may be placed closer together or on the same pole, with approval by the Engineer. If two pushbuttons are placed on the same pole or with less than 10 feet separation, provide a speech walk message for the WALK indication and a speech pushbutton information message.

Adjust the intensity of the pushbutton locator tones so they are audible 6 feet to 12 feet from the pushbutton, or to the building line, whichever is less. Ensure the pushbutton locator tones are no more than 5 dBA louder than ambient sound. Configure audible “Walk” indication to be audible at the nearest end of the associated crosswalk.

If speech messages are used, have each recorded custom speech message approved by the Engineer in advance.

4.4. MEASUREMENT AND PAYMENT

Actual number of push button integrated accessible pedestrian signal detector stations furnished, installed, and accepted.

Actual number of central control units for APS detector stations furnished, installed, and accepted.

Actual number of push button posts furnished, installed, and accepted.

No measurement will be made of cables or hardware, as these will be considered incidental to furnishing and installing push button integrated accessible pedestrian signals.

Payment will be made under:

APS Detector Stations.....	Each
Central Control Units For APS Detector Stations	Each
Push button Posts	Each

5. VIDEO IMAGING LOOP EMULATOR DETECTOR SYSTEMS

5.1. DESCRIPTION

Design, furnish, provide training, and install video imaging loop emulator detection systems with all necessary hardware in accordance with the plans and specifications.

Unless otherwise specified in the contract, all loop emulator detection equipment will remain the property of the contractor.

5.2. MATERIALS

A. General:

Material and equipment furnished under this section must be pre-approved on the Department’s QPL by the date of installation except miscellaneous hardware such as cables and mounting hardware do not need to be pre-approved.

Used equipment will be acceptable provided the following conditions have been met:

- Equipment is listed on the current QPL.

TS-60

- Equipment is in good working condition.
- Equipment is to remain the property of the contractor.

Ensure that software is licensed for use by the Department and by any other agency responsible for maintaining or operating the loop emulation system. Provide the Department with a license to duplicate and distribute the software as necessary for design and maintenance support.

Design and furnish video imaging loop emulator detection systems that detect vehicles at signalized intersections by processing video images and providing detection outputs to the signal controller in real time (within 112 milliseconds of vehicle arrival).

Furnish all required camera sensor units, loop emulator processor units, hardware and software packages, cabling, poles, mast arms, harnesses, camera mounting assemblies, surge protection panels, grounding systems, messenger cable and all necessary hardware. Furnish systems that allow the display of detection zones superimposed on an image of the roadway on a Department-furnished monitor or laptop computer screen. Ensure detection zones can be defined and data entered using a simple keyboard or mouse and monitor, or using a laptop PC with software.

Provide design drawings showing design details and camera sensor unit locations for review and acceptance before installation. Provide mounting height and location requirements for camera sensor units on the design based on site survey. Design video imaging loop emulator detection systems with all necessary hardware. Indicate all necessary poles, spans, mast arms, luminaire arms, cables, camera mounting assemblies and hardware to achieve the required detection zones where Department owned poles are not adequate to locate the camera sensor units. Do not design for the installation of poles in medians.

Obtain the Engineer's approval before furnishing video imaging loop emulator detection systems. The contractor is responsible for the final design of video imaging loop emulator detection systems. Review and acceptance of the designs by the Department does not relieve the contractor from the responsibility to provide fully functional systems and to ensure that the required detection zones can be provided.

Provide the ability to program each detection call (input to the controller) with the following functions:

- Full Time Delay – Delay timer is active continuously,
- Normal Delay – Delay timer is inhibited when assigned phase is green (except when used with TS 2 and 170/2070L controllers),
- Extend – Call is extended for this amount of time after vehicle leaves detection area,
- Delay Call/Extend Call – This feature uses a combination of full time delay and extend time on the same detection call. Ensure operation is as follows: Vehicle calls are received after the delay timer times out. When a call is detected, it is held until the detection area is empty and the programmed extend time expires. If another vehicle enters the detection area before the extend timer times out, the call is held and the extend time is reset. When the extend timer times out, the delay timer has to expire before another vehicle call can be received.

Provide the ability to program each detection zone as one of the following functions:

- Presence detector,

TS-61

- Directional presence detector,
- Pulse detector,
- Directional pulse detector.

Ensure previously defined detector zones and configurations can be edited.

Provide each individual system with all the necessary equipment to focus and zoom the camera lenses without the need to enter the camera enclosure.

Provide systems that allow for the placement of at least 8 detection zones within the combined field of view of a single camera sensor unit. Provide a minimum of 8 detection outputs per camera.

Provide detection zones that can be overlapped. Ensure systems reliably detect vehicles when the horizontal distance from the camera sensor unit to the detection zone area is less than ten times the mounting height of the sensor. Ensure systems detect vehicles in multiple travel lanes.

Ensure systems can detect vehicle presence within a 98 to 102 percent accuracy (up to 2 percent of the vehicles missed and up to 2 percent of false detection) for clear, dry, daylight conditions, a 96 to 105 percent accuracy (up to 4 percent of the vehicles missed and up to 5 percent false detection) for dawn and dusk conditions, and a 96 percent accuracy (up to 4 percent of the vehicles missed) for night and adverse conditions (fog, snow, rain, etc.) using standard sensor optics and in the absence of occlusion.

Repair and replace all failed components within 72 hours.

The Department may conduct field-testing to ensure the accuracy of completed video imaging loop emulator detection systems.

B. Loop Emulator System:

Furnish loop emulator systems that receive and simultaneously process information from camera sensor units, and provides detector outputs to signal controllers.

Ensure systems provide the following:

- Operate in a typical roadside environment and meet the environmental specifications and are fully compatible with NEMA TS 1, NEMA TS 2, or Type 170/2070L controllers and cabinets,
- provide a “fail-safe” mode whereby failure of one or more of the camera sensor units or power failure of the loop emulator system will cause constant calls to be placed on the affected vehicle detection outputs to the signal controller,
- provide compensation for minor camera movement of up to 2 percent of the field of view at 400 feet without falsely detecting vehicles,
- process the video at a minimum rate of 30 times per second,
- provide separate wired connectors inside the controller cabinet for video recording each camera,
- provide remote video monitoring with a minimum refresh rate at 1 frame per second over a standard dial-up telephone line,
- provide remote video detection monitoring.

TS-62

Furnish camera sensor units that comply with the following:

- have an output signal conforming to EIA RS-170 standard,
- have a nominal output impedance of 75 ohms,
- be immune to bright light sources, or have built in circuitry or protective devices to prevent damage to the sensor when pointed directly at strong light sources,
- be housed in a light colored environmental enclosure that is water proof and dust tight, and that conforms to NEMA-4 specifications or better,
- simultaneously monitor at least five travel lanes when placed at the proper mounting location with a zoom lens,
- have a sunshield attached to the environmental enclosure to minimize solar heating,
- meet FCC class B requirements for electromagnetic interference emissions,
- have a heater attached to the viewing window of the environmental enclosure to prevent ice and condensation in cold weather.

Where coaxial video cables and other cables are required between the camera sensor and other components located in the controller cabinet, furnish surge protection in the controller cabinet.

If furnishing coaxial communications cable comply with the following, as recommended by the approved loop emulator manufacturer:

- Number 20 AWG, solid bare copper conductor terminated with crimped-on BNC connectors (do not use BNC adapters) from the camera sensor to the signal controller cabinet.
- Number 22 AWG, stranded bare copper conductor terminated with crimped-on BNC connectors (do not use BNC adapters) from the camera sensor unit to the junction box, and within the signal controller cabinet.

Furnish power cable appropriately sized to meet the power requirements of the sensors. At a minimum, provide three conductor 120 VAC field power cable.

As determined during the site survey, furnish sensor junction boxes with nominal 6 x 10 x 6 inches dimensions at each sensor location. Provide terminal blocks and tie points for coaxial cable.

C. Video Imaging Loop Emulator System Support:

Furnish video imaging loop emulator systems with either a simple keyboard or a mouse with monitor and appropriate software, or with system software for use on department-owned laptop PCs. Ensure the system is Windows 2000 and Windows XP compatible.

Provide Windows 2000 and Windows XP compatible personal computer software, if needed, to provide remote video and video detection monitoring.

Ensure systems allow the user to edit previously defined detector configurations. When a vehicle is within a detection zone, provide for a change in color or intensity of the detection zone perimeter or other appropriate display changes on the Department-furnished monitor or laptop computer screen.

Provide cabling and interconnection hardware with 6-foot minimum length interconnection cable to interface with the system.

TS-63

Provide all associated equipment manuals and documentation.

5.3. CONSTRUCTION METHODS

Arrange and conduct site surveys with the system manufacturer's representative and Department personnel to determine proper camera sensor unit selection and placement. Provide the Department at least 3 working days notice before conducting site surveys. Upon completion of the site surveys the Department will provide revised plans reflecting the findings of the site survey.

Before beginning work at locations requiring video imaging loop emulator detection systems, furnish system software. Upon activation of detection zones, provide detector configuration files. Ensure that up-to-date detection configuration files are furnished for various detection zone configurations that may be required for construction phasing.

Place into operation loop emulator detection systems. Configure loop emulator detection systems to achieve required detection in designated zones. Have a certified manufacturer's representative on site to supervise and assist with installation, set up, and testing of the system.

Install the necessary processing and communications equipment in the signal controller cabinet. Make all necessary modifications to install equipment, cabling harnesses, and camera sensor interface panels with surge suppression.

Perform modifications to camera sensor unit gain, sensitivity, and iris limits necessary to complete the installation.

Do not install camera sensor units on signal poles unless approved by the Engineer.

Install the necessary cables from each sensor to the signal controller cabinet along signal cabling routes. Install surge protection and terminate all cable conductors.

Relocate camera sensor units and reconfigure detection zones as necessary according to the plans for construction phases.

Provide at least 8 hours of training on the set up, operation, troubleshooting, and maintenance of the loop emulator detection system to a maximum of ten Department personnel. Arrange for training to be conducted by the manufacturer's representative at an approved site within the Division responsible for administration of the project. Thirty days before conducting training submit a detailed course curriculum, draft manuals and materials, and resumes. Obtain approval of the submittal before conducting the training. At least one week before beginning training, provide three sets of complete documentation necessary to maintain and operate the system. Do not perform training until installation of loop emulator detection systems is complete.

5.4. MEASUREMENT AND PAYMENT

Actual number of site surveys, arranged, conducted, and accepted.

Actual number of luminaire arms for video systems furnished, installed, and accepted.

Actual number of cameras with internal loop emulator processing units furnished, installed, and accepted.

Actual number of cameras without internal loop emulator processing units furnished, installed, and accepted.

Actual number of external loop emulator processing units furnished, installed, and accepted.

TS-64

Actual number of camera sensor units relocated with detection zones reconfigured installed, and accepted.

No measurement will be made of video imaging loop emulator system support or training, power and video cables, and trenching as these items will be considered incidental to furnishing and installing video imaging loop emulator detection systems.

Payment will be made under:

Site Survey	Each
Luminaire Arm for Video System	Each
Camera with Internal Loop Emulator Processing Unit.....	Each
Camera without Internal Loop Emulator Processing Unit.....	Each
External Loop Emulator Processing Unit	Each
Relocate Camera Sensor Unit	Each

6. MICROWAVE VEHICLE DETECTOR – SINGLE ZONE

6.1. DESCRIPTION

Furnish and install a microwave vehicle detection unit and manufacturer recommended cables and hardware in accordance with the plans and specifications.

6.2. MATERIALS

Furnish material, equipment, and hardware under this section that is pre-approved on the ITS and Signals QPL.

Provide a detector for either side-fire or forward-fire configuration. Ensure the detector will detect vehicle in sunny, cloudy, rainy, snowy, and foggy weather conditions with self-tuning to auto-adjust in changing environmental conditions. Ensure the detector can operate from the voltage supplied by a NEMA and Type-170 traffic signal cabinet. Ensure the detector can provide detection calls to the traffic signal controller within a NEMA and Type-170 cabinet. Ensure the detector will put out a constant call in the event of a component failure or loss of power. Ensure the detector has an operating temperature range of -20 to 150 degrees F. Ensure a water resistant housing for the detector.

For advance pulse detection, ensure the detector senses vehicles in motion at a range of 200 feet with an operating frequency of 10.525 GHz +/- 25MHz.

For stop bar presence detection, ensure the detector outputs a constant call while a vehicle is in the detection zone. Ensure the presence detection unit can cover a detection zone as shown on the plans and has an effective range of at least 75 feet from the detector unit to the aim point on the road surface.

For units without an integrated card rack interface, provide Form C output relay contacts rated a minimum of 3A, 24VDC.

If a laptop is used to adjust detector settings, ensure that software is licensed for use by the Department and by any other agency responsible for maintaining or operating the microwave detection system. Provide the Department with a license to duplicate and distribute the software as necessary for design and maintenance support.

TS-65

6.3. CONSTRUCTION METHODS

Install the microwave vehicle detector in accordance with the manufacturer's recommendations.

Monitor and maintain the detector unit during construction to ensure microwave vehicle detector is functioning properly and aimed for the detection zone shown in the plans. Refer to Subarticle 1700-3 (D) Maintenance and Repair of Materials of the *Standard Specifications* for failure to maintain the microwave detection system.

6.4. MEASUREMENT AND PAYMENT

Actual number of microwave vehicle detector units furnished, installed, and accepted.

No measurement will be made of cables or hardware, as these will be considered incidental to furnishing and installing microwave vehicle detectors.

Payment will be made under:

Microwave Vehicle Detector – Single Zone..... Each

7. MICROWAVE VEHICLE DETECTION SYSTEM - MULTIPLE DETECTION ZONES

7.1. DESCRIPTION

Design, furnish and install a microwave vehicle detection system with the manufacturer recommended cables and hardware in accordance to the plans and specifications. Ensure the detection system provides multiple detection zones.

7.2. MATERIALS

Provide design drawings showing design details and microwave sensor locations for review and acceptance before installation. Provide mounting height and location requirements for microwave sensor units on the design based on a site survey. Design microwave vehicle detection system with all necessary hardware. Indicate all necessary poles, spans, mast arms, luminaire arms, cables, microwave sensor mounting assemblies and hardware to achieve the required detection zones where Department owned poles are not adequate to locate the microwave sensor units. Do not design for the installation of poles in medians.

Obtain the Engineer's approval before furnishing microwave vehicle detection system. The contractor is responsible for the final design of microwave vehicle detection system. Review and acceptance of the designs by the Department does not relieve the contractor from the responsibility to provide fully functional systems and to ensure that the required detection zones can be provided. With the exception of contractor-furnished poles, mast arms, and luminaire arms, furnish material, equipment, and hardware under this section that is pre-approved on the ITS and Signals QPL. Submit and obtain Engineer's approval of shop drawings for any poles, mast arms, and luminaire arms provided by the contractor prior to ordering from manufacturer.

Provide a detector for either side-fire or forward-fire configuration. Ensure the detector will detect vehicles in sunny, cloudy, rainy, snowy, and foggy weather conditions. Ensure the detector can operate from the voltage supplied by a NEMA TS-1/TS-2 or Type 332 or 336 traffic signal cabinet. Ensure the detector can provide detection calls to the traffic signal controller within a NEMA TS-1/TS-2 or Type 332 or 336 cabinet. Ensure the detection system provides a constant call in the event of a component failure or loss of power. Ensure the detector has an operating temperature range of -30 to 165 degrees F and operates within the frequency range of 10 to 25 GHz.

TS-66

Ensure the detector is provided with a water-tight housing offering NEMA 4X protection and operates properly in up to 95% relative humidity, non-condensing.

Provide each detector unit to allow the placement of at least 8 detection zones with a minimum of 8 detection channel outputs. When the microwave vehicle detection system requires an integrated card rack interface(s), provide only enough interface cards to implement the vehicle detection shown on the signal plans. Provide a means acceptable to the Engineer to configure traffic lanes and detection zones. Provide each channel output with a programmable means to delay the output call upon activation of a detection zone that is adjustable in one second increments (maximum) over the range of 0 to 25 seconds. Provide each channel output with a programmable means to extend the output call that is adjustable in one second increments (maximum) over the range of 0 to 25 seconds. Ensure both delay and extend timing can be set for the same channel output.

For advance detection system, ensure the detector senses vehicles in motion at a range of 50 to 400 feet from the detector unit for forward-fire configuration and a range of 50 to 200 feet from the detector unit for side-fire configuration with an accuracy of 95% for both configurations. Ensure the advance detection system provides each channel output call of at least 100 ms in duration.

For stop bar presence detection system, ensure the detector outputs a constant call while a vehicle is in the detection zone and removes the call after all vehicles exit the detection zone. Ensure the presence detector unit can cover a detection zone as shown on the plans and has an effective range of 10 to 120 feet from the detector unit.

For units without an integrated card rack interface, provide Form C output relay contacts rated a minimum of 3A, 24VDC.

If a laptop is used to adjust detector settings, ensure that software is licensed for use by the Department and by any other agency responsible for maintaining or operating the microwave detection system. Provide the Department with a license to duplicate and distribute the software as necessary for design and maintenance support.

After initial detector configuration and installation, ensure routine adjustments or calibration are not needed to maintain acceptable performance.

7.3. CONSTRUCTION METHODS

Install the microwave vehicle detection system in accordance with the manufacturer's recommendations.

Monitor and maintain each detector unit during construction to ensure microwave vehicle detection system is functioning properly and aimed for the detection zone shown in the plans. Refer to Subarticle 1700-3 (D) Maintenance and Repair of Materials of the *Standard Specifications* for failure to maintain the microwave detection system.

7.4. MEASUREMENT AND PAYMENT

Actual number of microwave vehicle detection systems – multiple zones furnished, installed, and accepted.

No measurement will be made of cables or hardware, as these will be considered incidental to furnishing and installing microwave vehicle detection systems.

Payment will be made under:

TS-67

Microwave Vehicle Detection System – Multiple Zones Each

8. WIRELESS MAGNETIC SENSOR VEHICLE DETECTION SYSTEM

8.1. DESCRIPTION

Furnish a vehicle detection system that uses battery-powered magnetic field sensors for pavement installation that communicate traffic detection data by wireless communication to a transceiver for a local traffic signal cabinet. Ensure each sensor responds to the change in the earth's local magnetic field resulting from the presence and passage of a vehicle. Ensure the system contains sensor(s), transceiver(s), and any other device(s) to provide detection data to a traffic signal controller.

8.2. MATERIALS

Furnish material, equipment, and hardware under this section that is pre-approved on the ITS and Signals QPL.

Provide magnetic sensors to detect vehicle traffic such as cars, trucks, and motorcycles. Ensure each sensor is sized for an installation into a 4-inch diameter by 3-inch deep hole. Ensure the sensor provides vehicle traffic data for volume and occupancy. Ensure the sensor holds a detection call when a vehicle is stopped in its detection field. Provide a sensor to simulate a detection zone of a 6' x 6' inductive loop. Provide a combination of sensors to simulate a detection zone of a 6' x 40' quadrupole inductive loop and a 6' x 60' quadrupole inductive loop. Ensure the sensors operate as specified by the intersection design plans.

Provide two-way wireless communication between the sensors and the transceiver devices. Ensure no disruption to the wireless communication when the transceiver devices are located on the side of the road surface. Ensure that the sensors can communicate with the transceiver devices for a minimum distance of 100 feet. Ensure all wireless communications within the system operate in an unlicensed frequency band and avoid interference with other devices operating in the unlicensed frequency band. Provide at least 16 frequency channels that are user-configurable.

Provide each sensor to transmit its detection data within 150 ms of a detected event. Ensure the sensor samples the earth's magnetic field at a rate of 128 Hz or faster. Ensure that each sensor transmits a unique identifying code. Ensure that each sensor automatically recalibrates its threshold values in response to changes in the ambient magnetic field based on user-programmed criteria.

Furnish each sensor that is manufactured as a single housing module that conforms to NEMA Type 6P enclosure. Ensure that the components of the sensor are fully encapsulated within the housing to prevent moisture from degrading the components. Ensure the sensor operates at temperatures from -37 degrees F to 176 degrees F. Provide battery-power with an average life expectancy of 10 years when the sensor is operating under normal traffic conditions.

Provide a clear injection molded clamshell style case made of polypropylene for protecting the sensor in the roadway. Ensure case protects the sensor from sealant material. Ensure the case holds the sensor in place and is form-fitting to ensure cured sealant does not collapse when exposed to traffic loads.

Furnish the transceiver to provide detection data to the traffic signal cabinet and ensure the traffic signal controller receives each sensor detection call. Ensure the traffic signal controller receives both presence mode and pulse mode detection calls.

TS-68

Provide indications inside the traffic signal cabinet to display each channel detection status and fault condition. Provide a means to select presence mode and pulse mode for each channel. Provide user-selectable sensitivity levels for vehicle detection. Furnish equipment to operate in Type 332 and 336S traffic signal cabinets.

Provide software for installation and use on personal computers to upload and download configuration data to each sensor. Ensure application software is compatible with Windows 7 operating system. Ensure software does not require administrative permissions to load and operate. Ensure the software can retrieve and store detection data from the sensors. Ensure the software on the personal computer transmits data from the personal computer to each sensor through the transceiver by wireless communication. Also, provide any update to the firmware in each sensor by wireless communication. Provide a license to the Department to allow the duplication of the personal computer software as needed to design, install and maintain these systems.

8.3. CONSTRUCTION METHODS

Install the wireless magnetic sensor vehicle detector system in accordance with the manufacturer's recommendations. Enclose the wireless magnetic sensor in a molded clamshell style case before installation into the roadway. When installing each sensor into the hole, ensure epoxy sufficiently covers the sensor in the road surface.

Arrange and conduct site surveys with the system manufacturer's representative and Department personnel to determine proper sensor and transceiver selection and placement. Provide the Department at least 3 working days notice before conducting site surveys. The Engineer will approve final locations of sensors, transceivers and any necessary repeaters.

Install the transceiver in such a manner that avoids conflicts with other utilities and as specified in the manufacturer's recommendations. Secure the transceiver mounting hardware to the pole and route the cabling such that no strain is placed on connectors.

Before beginning work at locations that require a wireless magnetic sensor vehicle detector system, furnish system software. Upon activation of the system, provide detector configuration files.

Place system into operation. Configure wireless magnetic sensor vehicle detector system to achieve required detection in designated areas. Have a certified manufacturer's representative on site to supervise and assist with installation, set up, and testing of the system.

Install the necessary processing and communications equipment in the signal controller cabinet. Make all necessary modifications to install equipment in cabinet. Ensure the traffic signal controller receives each sensor detection call.

Place a copy of all manufacturer equipment specifications and instruction and maintenance manuals in the equipment cabinet.

Provide at least 4 hours of training on the set up, operation, troubleshooting, and maintenance of the wireless magnetic sensor vehicle detector system to a maximum of ten Department personnel. Arrange for training to be conducted by the manufacturer's representative at an approved site within the Division responsible for administration of the project. Thirty days before conducting training submit a detailed course curriculum, draft manuals and materials, and resumes. Obtain approval of the submittal before conducting the training. At least one week before beginning training, provide three sets of complete documentation necessary to maintain and operate the system. Do not perform training until installation of the wireless magnetic sensor vehicle detector system is complete.

TS-69

8.4. MEASUREMENT AND PAYMENT

Actual number of wireless magnetic sensor vehicle detector systems furnished, installed, and accepted.

No measurement will be made of cables or hardware, as these will be considered incidental to furnishing and installing wireless magnetic sensor vehicle detector system.

Payment will be made under:

Wireless Magnetic Sensor Vehicle Detector System.....Each

9. GPS UNIT

9.1. DESCRIPTION

Furnish and install a GPS unit in the traffic signal cabinet for time synchronization in accordance with the plans and specifications. Comply with the provisions of Section 1700 of the 2018 Standard Specifications for Roads and Structures.

9.2. MATERIALS

Provide Trimble Acutime GG Smart Antenna, or an approved equivalent, for time synchronization that is compatible with Oasis 2070 controller software.

9.3. CONSTRUCTION METHODS

Mount GPS antenna on pole adjacent to cabinet at a minimum height of 10' insuring that the antenna can acquire enough satellites to be accurate. Use 3/4" rigid metallic conduit with appropriate fittings for mounting the antenna and running the lead-in cable. Provide GPS antenna lead-in cable that is not more than 50' in length. Provide a drip loop in the cable before it enters the conduit. Insure the cable entry point into the conduit is waterproof. If a pole is not within 30' of the cabinet, the GPS antenna may be mounted to the top of the cabinet, while insuring that the connection point into the cabinet is waterproof.

9.4. MEASUREMENT AND PAYMENT

Actual number of GPS units furnished, installed, and accepted.

No measurement will be made for interface cables and connectors, as these are considered incidental to furnishing and installing the GPS unit assemblies.

Payment will be made under:

GPS Unit.....Each

10. TEMPORARY STATIONARY TRAFFIC SIGNAL SYSTEM

10.1. DESCRIPTION

Furnish, install, place in operation, repair, maintain, reposition, and remove the temporary stationary traffic signal system. Comply with the provisions of Section 1700 of the 2018 Standard

TS-70

Specifications for Roads and Structures and the generic Project Special Provisions for Signals and Intelligent Transportation Systems located at:

<http://www.ncdot.org/doh/preconstruct/traffic/ITSS/>

10.2. MATERIALS

Provide a complete temporary traffic signal system including but not limited to 12-inch vehicle signal heads, signal cable, messenger cable, wood poles, guy assemblies, inductive detection loops, microwave vehicle detectors, lead-in cable, trenching, riser assemblies, required signs, detector units, 2070 controller with 336 pole mounted cabinet, and appropriate pavement markings.

All traffic signal equipment must be in compliance with the plans provided by NCDOT (**plans will be provided upon request from the contractor**), the project special provisions, and the 2018 Standard Specifications for Roads and Structures.

10.3. CONSTRUCTION METHODS

NCDOT will provide the temporary stationary traffic signal plans **30 days** after **written request** is submitted to the Engineer. Plan requests shall consist of the following information: a drawing showing the exact location of the stopbars (include Stations), speed limit posted during operation, percent grade on each approach, times and duration of operation.

Ensure that the signal meets the physical display and operational requirements of conventional traffic signals as specified in PART IV of the *Manual on Uniform Traffic Control Devices (MUTCD)* and the *North Carolina Supplement to the MUTCD* in effect on the date of advertisement.

Perform all maintenance operations required by the manufacturer. Have properly skilled and trained maintenance personnel available to maintain the system in good working order and to perform all emergency and preventive maintenance as recommended by the equipment manufacturer.

Furnish the Engineer with the name, office telephone number, cellular (mobile) telephone number, and pager number of the supervisory employee who will be responsible for maintenance and repair of equipment during all hours.

In the event that the signal becomes inoperative, be prepared at all times to revert to a flagging operation or suspend all construction activities requiring the use of the temporary stationary traffic signal system until the signal is restored to proper operation.

Remove signals within two weeks of completion of work requiring the use of temporary stationary traffic signal system.

10.4. MEASUREMENT AND PAYMENT

Actual number of **days** that each Temporary Stationary Traffic Signal System is operated.

No measurement will be made for operation, relocation, maintenance, removal of each signal system, or use of flaggers during repair periods as these will be considered incidental to furnishing, installing, and operating the Temporary Traffic Signal System.

Any Temporary Stationary Traffic Signal System used for less than one hour will be considered incidental to the operation that required the use of such signal.

No measurement will be made for signal controller, communication cable, messenger cable, wireless communication, inductive loop sawcut, loop emulator detection system, machine vision

TS-71

detection system, microwave detection system, detector channel/unit, detector lead-in cable, trenching, vehicle signal heads, signal head support assemblies, signal cable, and traffic signal software as these will be considered incidental to furnishing, installing, and operating the Temporary Traffic Signal System.

Refer to “Temporary Traffic Signal System Alternates” Special Provision for payment.

11. PORTABLE TRAFFIC SIGNAL SYSTEM

11.1. DESCRIPTION

Furnish, install, place in operation, repair, maintain, relocate, and remove portable traffic signal systems. Comply with the provisions of Section 1700 of the 2018 Standard Specifications for Roads and Structures.

11.2. MATERIALS

Furnish material, equipment, and hardware under this section that is pre-approved on the ITS and Signals QPL.

Provide a complete portable traffic signal system that is totally mobile and capable of being relocated as traffic conditions demand. Design the system for operation both with and without an external power source. Furnish two signal control trailers with two vehicle signal heads per trailer and one operator unit for each portable traffic signal system. Furnish transmitters, generators, batteries, controls, back-up systems and all other components necessary to operate the system.

Ensure each system meets the physical display and operational requirements of conventional traffic signals as specified in PART IV of the Manual on Uniform Traffic Control Devices (MUTCD) and the North Carolina Supplement to the MUTCD in effect on the date of advertisement.

Used equipment will be acceptable if the equipment is in good working condition. Contractor retains ownership of the portable traffic signal systems.

Provide yellow 12-inch aluminum or polycarbonate vehicle signal heads with 10-inch tunnel visors, backplates and Light Emitting Diode (LED) modules. Provide aluminum signal heads and backplates listed on the Department’s Qualified Products List (QPL) for traffic signal equipment. Provide polycarbonate signal heads and visors that comply with the provisions pertaining to Signal Heads within these Project Special Provisions with the following exceptions:

Fabricate signal head housings, end caps, and visors from virgin polycarbonate material. Provide U.V. stabilized polycarbonate plastic with a minimum thickness of 0.1 ± 0.01 inches that is highway yellow (Federal Standard 595C, Color Chip 13538). Ensure the color is incorporated into the plastic material before molding the signal head housings and end caps. Ensure the plastic formulation provides the following physical properties in the assembly (tests may be performed on separately molded specimens):

TS-72

Test	Required	Method
Specific Gravity	1.17 minimum	ASTM D 792
Vicat Softening Temperature, °F	305-325	ASTM D 1525
Brittleness Temperature, °F	Below –200	ASTM D 746
Flammability	Self-extinguishing	ASTM D 635
Tensile Strength, yield, PSI	8500 minimum	ASTM D 638
Elongation at yield, %	5.5-8.5	ASTM D 638
Shear, strength, yield, PSI	5500 minimum	ASTM D 732
Izod impact strength, ft-lb/in [notched, 1/8 inch]	15 minimum	ASTM D 256
Fatigue strength, PSI at 2.5 mm cycles	950 minimum	ASTM D 671

To minimize signal head movement due to wind, mount top and bottom of signal heads to the signal head supports.

Provide 120V AC powered LED modules listed on the QPL, or provide 12V DC powered LED modules that meet the ITE VTCSH Part 2: Light Emitting Diode (LED) Vehicle Signal Modules (Interim Purchase Specification) with the exception of paragraphs 5.2, 5.3, 5.7, and testing associated with 120V AC. Ensure DC powered LED modules operate with input power between 9V DC and 15V DC.

Provide trailers that have durable paint in highway orange, Federal Standard 595C Color Chip ID # 12473 with a minimum paint thickness of 2.5 mils.

Provide trailers with a 12-volt trailer lighting system complying with Federal Motor Carrier Safety Regulations 393, safety chains, and a 2-inch ball hitch. When provided, locate generators, fuel tanks, batteries and electronic controls in protective housings that are provided with locks to restrict access.

Design the trailer assembly and signal supports to withstand an 80 MPH wind load with the signal supports raised in the operating position. Provide independent certification from a registered Professional Engineer that the assembly meets this 80 MPH wind load requirement. Provide a reliable hydraulic, electric or manual means for raising and lowering the signal support members. Provide screw-type stabilizing and leveling devices with a self-leveling foot to support the unit in the operating position on slopes 1V:3H or flatter when detached from the transporting vehicle.

During manual operation, ensure the system provides a means of informing the operator of signal indications, such as a light on the back of each signal head that illuminates when the signal displays a red indication.

Design the portable traffic signal system to perform without interruption during the time it is in operation.

Where a traffic actuated system is required, provide a system control unit that is capable of pre-timed operation, traffic actuated operation, a variable green time interval dependent upon vehicle

TS-73

actuators, and programmable yellow clearance and red clearance intervals. Furnish all sensors to monitor vehicle demands for vehicle actuation per the Project Special Provisions and Section 1098 of the Standard Specifications.

Design the systems to be fail-safe. Ensure the system monitors the following conditions: lack of green, yellow, and red signal indication voltage, total loss of indication on any approach, presence of multiple signal indications on any approach, conflicting green/yellow signal indications, and low power condition. In the event any of these conditions are detected, immediately begin flashing operation of red indications in all directions.

Provide either hard-wired, microwave, or radio controlled type communications for pre-timed and traffic actuated portable traffic signal systems. In the event a loss of communication is detected, immediately begin flashing operation of red indications in all directions.

Ensure systems that use wireless communication links continuously monitor and verify proper transmission and reception of data used to monitor and control each signal head. Ensure ambient mobile or other radio transmissions or adverse weather conditions do not affect the system. Encode signal transmissions digitally to protect radio transmissions from interference. Do not violate FCC regulations and ensure radio frequencies are appropriate for portable signal equipment applications.

Upon detecting a malfunction, ensure all signals go to a flashing red condition and the operator is notified by a reliable means approved by the Engineer. Provide a battery back-up system for generator and direct current powered signal systems to power the warning means and "flashing red" condition. Provide a back-up system with a 72-hour minimum reserve.

Ensure the system meets the Environmental Standards for traffic signals in accordance with NEMA TS-1, Section 2.

11.3. CONSTRUCTION METHODS

Do not use portable traffic signal systems in a work area with intersecting streets or driveways, unless directed by the Engineer.

Do not install portable traffic signal within 300 feet of at-grade railroad crossing.

During automatic operation, ensure the motorist has an unobstructed view of opposing traffic.

Ensure the distance between signal units does not exceed 500 feet unless otherwise shown on the plans or directed by the Engineer. If modification to the distance between signal units is required after the units are positioned, relocate the signals or the system and make the necessary timing revisions only as directed by the Engineer.

Submit a traffic signal timing plan to the Engineer for approval a minimum of two weeks prior to installation. Include the following items in the plan: distance between stop bars, speed limit to be posted during operation, each approach grade, recommended yellow change interval, recommended red clearance interval, recommended minimum and maximum green intervals. Make timing changes to approved signal timing plan only as authorized by the Engineer. Keep a written record of all timing changes.

Allow only trained operators to set up and operate the system. Provide an experienced operator at all times for each portable traffic signal system during periods of manual operation. Do not violate yellow change and red clearance intervals during periods of manual operation. During manual operation, ensure the operator has an unobstructed view of the motorists and all signal head units. Locate the operator as close to the center of the operation as possible.

TS-74

Perform all maintenance operations required by the system manufacturer including periodic cleaning of the systems. Ensure properly skilled and trained maintenance personnel are available to maintain the system in good working order and to perform all emergency and preventive maintenance as recommended by the system manufacturer.

Furnish the Engineer with the name, office telephone number, cellular (mobile) telephone number, and pager number of the supervisory employee who will be responsible for maintenance and repair of equipment during all hours.

For all failures, malfunctions, or damage to this equipment, begin necessary repairs within four hours of notification. Complete repairs within eight hours of notification. Comply with Section 150 of the Standard Specifications for maintenance of traffic flow. The inability to contact the supervisory employee or prearranged alternate will not extend repair time requirements.

In the event that the system becomes inoperative, be prepared at all times to revert to flagging operations or suspend all construction activities requiring the use of the portable traffic signal system until the system is restored to proper operation. Implement flagging operations as shown on 2018 Roadway Standard Drawing No. 1101.02 Sheet 1 (Closure of one lane of a Two-lane, Two-way Highway).

When not in operation, remove signal heads from the view of traffic or cover signal heads with burlap bags or bags made of non-ripping material specifically designed for covering signal heads. Do not use trash bags of any type. Remove, cover, fold, or turn all inappropriate signs so that they are not readable by oncoming traffic.

11.4. MEASUREMENT AND PAYMENT

Actual number of portable traffic signal systems furnished, installed, operated, removed, and accepted.

No measurement will be made for operation, relocation, maintenance, removal of each system, or use of flaggers during repair periods as these will be considered incidental to furnishing, installing, and operating the portable traffic signal systems.

No measurement will be made for signal controller, communication cable, messenger cable, wireless communication, inductive loop sawcut, loop emulator detection system, machine vision detection system, microwave detection system, detector channel/unit, detector lead-in cable, trenching, vehicle signal heads, signal head support assemblies, signal cable, and traffic signal software as these will be considered incidental to furnishing, installing, and operating the portable traffic signal systems.

Payment will be made under:

Portable Traffic Signal System (actuated)	Each
Portable Traffic Signal System (pre-timed)	Each

12. TRAFFIC SIGNAL SUPPORTS

12.1. METAL TRAFFIC SIGNAL SUPPORTS – ALL POLES

A. General:

Furnish and install metal strain poles and metal poles with mast arms, grounding systems, and all necessary hardware. The work covered by this special provision includes requirements for the

TS-75

design, fabrication, and installation of both standard and custom/site specifically designed metal traffic signal supports and associated foundations.

Provide metal traffic signal support systems that contain no guy assemblies, struts, or stay braces. Provide designs of completed assemblies with hardware that equals or exceeds AASHTO *Standard Specifications for Structural Supports for Highway Signs, Luminaires and Traffic Signals* 6th Edition, 2013 (hereafter called 6th Edition AASHTO), including the latest interim specifications. Provide assemblies with a round or near-round (18 sides or more) cross-section, or a multi sided cross section with no less than six sides. The sides may be straight, convex, or concave.

Pole heights shown on signal plans are estimated from available data for bid purposes. Prior to furnishing metal signal poles, use field measurements and adjusted cross-sections to determine whether pole heights are sufficient to obtain required clearances. If pole heights are not sufficient, the Contractor should immediately notify the Engineer of the required revised pole heights.

Ensure that metal signal poles permit cables to be installed inside poles and any required mast arms. For holes in the poles and arms used to accommodate cables, provide full-circumference grommets. Arm flange plate wire access holes should be deburred, non grommited, and oversized to fit around the 2” diameter grommited shaft flange plate wire access hole.

After fabrication, have steel poles, required mast arms, and all parts used in the assembly hot-dip galvanized per section 1076. Design structural assemblies with weep holes large enough and properly located to drain molten zinc during the galvanization process. Provide hot-dip galvanizing on structures that meets or exceeds ASTM Standard A-123. Provide galvanizing on hardware that meets or exceeds ASTM Standard A-153. Ensure that threaded material is brushed and retapped as necessary after galvanizing. Perform repair of damaged galvanizing that complies with the following:

Repair of Galvanizing.....Article 1076-7

Standard Drawings for Metal Poles are available that supplement these project special provisions. These drawings are located on the Department’s website:

<https://connect.ncdot.gov/resources/safety/pages/ITS-Design-Resources.aspx>

Comply with article 1098-1B of the *2018 STANDARD SPECIFICATIONS FOR ROADS & STRUCTURES*, hereinafter referred to as the *Standard Specifications* for submittal requirements. Furnish shop drawings for approval. Provide the copies of detailed shop drawings for each type of structure as summarized below. Ensure that shop drawings include material specifications for each component and identify welds by type and size on the detail drawing only, not in table format. **Do not release structures for fabrication until shop drawings have been approved by NCDOT.** Provide an itemized bill of materials for all structural components and associated connecting hardware on the drawings.

Comply with article 1098-1A of the *Standard Specifications* for Qualified Products List (QPL) submittals. All shop drawings must include project location description, signal inventory number(s) and a project number or work order number on the drawings.

Summary of information required for metal pole review submittal:

Item	Hardcopy Submittal	Electronic Submittal	Comments / Special Instructions

TS-76

Sealed, Approved Signal Plan/Loading Diagram	1	1	All structure design information needs to reflect the latest approved signal plans
Custom Pole Shop Drawings	4 sets	1 set	Show NCDOT inventory number(s), contractor's name and relevant revision number in the title block. All drawings must have a unique <u>drawing</u> number for each project and identified for multiple pages.
Standard Pole Shop Drawings (from the QPL)	4 sets	1 set	Submit drawings on 11" x 17" format media. Show NCDOT inventory number(s), contractor's name and relevant revision number in the title block. All drawings must have a <u>unique drawing</u> number for each project and identified for multiple pages.
Structure Calculations	1 set	1 set	Not required for Standard QPL Poles
Standard Pole Foundation Drawings	1 set	1 set	Submit drawings on 11" x 17" format media. Submit a completed Standard Foundation Selection form for each pole using foundation table on Metal Pole Drawing M-8.
Custom Foundation Drawings	4 sets	1 set	Submit drawings on 11" x 17" format media. Show NCDOT inventory number(s), contractor's name and relevant revision number in the title block. All drawings must have a <u>unique drawing</u> number for each project and identified for multiple pages. If QPL Poles are used, include the corresponding QPL pole shop drawings with this submittal.
Foundation Calculations	1	1	Submit copies of LPILE input, output and pile tip deflection graph per Section 11.4 of this specification for each foundation. Not required for Standard QPL Poles
Soil Boring Logs and Report	1	1	Report should include a location plan and a soil classification report including soil capacity, water level, hammer efficiency, soil bearing pressure, soil density, etc. for each pole.

NOTE – All shop drawings and custom foundation design drawings must be sealed by a Professional Engineer licensed in the state of North Carolina. All geotechnical information must be sealed by either a Professional Engineer or geologist licensed in the state of North Carolina. Include a title block and revision block on the shop drawings and foundation drawings showing the NCDOT inventory number.

Shop drawings and foundation drawings may be submitted together or separately for approval. However, shop drawings must be approved before foundations can be reviewed. Foundation designs will be returned without review if the associated shop drawing has not been approved. Boring reports should include the following: Engineer's summary, boring location maps,

TS-77

soil classification per AASHTO Classification System, hammer efficiency, and Metal Pole Standard Foundation Selection Form. Incomplete submittals will be returned without review. The Reviewer has the right to request additional analysis and copies of the calculations to expedite the approval process.

B. Materials:

Fabricate metal pole and arm shaft from coil or plate steel to meet the requirements of ASTM A 595 Grade A tubes. For structural steel shapes, plates and bars use A572 Gr 50 min or ASTM A709 Gr 50 min. Provide pole and arm shafts that are round in cross section or multisided tubular shapes and have a uniform linear taper of 0.14 in/ft. Construct shafts from one piece of single ply plate or coil so there are no circumferential weld splices. Galvanize in accordance with AASHTO M 111 or an approved equivalent.

Use the submerged arc process or other NCDOT previously approved process suitable for pole shaft and arms to continuously weld pole shafts and arm shafts along their entire length. The longitudinal seam weld will be finished flush to the outside contour of the base metal. Ensure shafts have no circumferential welds except at the lower end joining the shaft to the pole base and arm base. Use full penetration groove welds with backing ring for all tube-to-transverse-plate connections in accordance with 6th Edition AASHTO. Provide welding that conforms to Article 1072-18 of the *Standard Specifications*, except that no field welding on any part of the pole will be permitted unless approved by a qualified engineer.

Refer to Metal Pole Standard Drawing Sheets M2 through M5 for fabrication details. Fabricate anchor bases and mast arm connecting plates from plate steel meeting, as a minimum, the requirements of ASTM A572 Gr 50, AASHTO M270 Gr 50, ASTM A709 Gr50, or an approved equivalent. Conform to the applicable bolt pattern and orientation as shown on Metal Pole Standard Drawing Sheet M2.

Ensure all hardware is galvanized steel or stainless steel. The Contractor is responsible for ensuring that the designer/fabricator specifies connecting hardware and/or materials that do not create a dissimilar metal corrosive reaction.

Provide a minimum of four (4) 1-1/2" diameter high strength bolts for connection between arm plate and pole plate. Increase number of bolts to six (6) 1-1/2" diameter high strength bolts when arm lengths are greater than 50'-0" long.

Unless otherwise required by the design, ensure each anchor rod is 2" diameter and 60" length. Provide 10" minimum thread projection at the top of the rod, and 8" minimum at the bottom of the rod. Use anchor rod assembly and drilled pier foundation materials that meet the *Foundations and Anchor Rod Assemblies for Metal Poles* provision.

For each structural bolt and other steel hardware, hot dip galvanizing shall conform to the requirements of AASHTO M 232 (ASTM A 153). Ensure end caps for poles or mast arms are constructed of cast aluminum conforming to Aluminum Alloy 356.0F.

Provide a circular anchor bolt lock plate that will be secured to the anchor bolts at the embedded end with 2 washers and 2 nuts. Provide a base plate template that matches the bolt circle diameter of the anchor bolt lock plate. Construct plates and templates from 1/4" minimum thick steel with a minimum width of 4". Galvanizing is not required for both plates.

TS-78

Provide 4 heavy hex nuts and 4 flat washers for each anchor bolt. For nuts, use AASHTO M291 grade 2H, DH, or DH3 or equivalent material. For flat washers, use AASHTO M293 or equivalent material.

C. Construction Methods:

Erect signal support poles only after concrete has attained a minimum allowable compressive strength of 3000 psi. Install anchor rod assemblies in accordance with the *Foundations and Anchor Rod Assemblies for Metal Poles* provision.

For further construction methods, see construction methods for Metal Strain Pole, or Metal Pole with Mast Arm.

Connect poles to grounding electrodes and bond them to the electrical service grounding electrodes.

For holes in the poles used to accommodate cables, install grommets before wiring pole or arm. Do not cut or split grommets.

Attach the terminal compartment cover to the pole by a sturdy chain or cable. Ensure the chain or cable is long enough to permit the cover to hang clear of the compartment opening when the cover is removed, and is strong enough to prevent vandalism. Ensure the chain or cable will not interfere with service to the cables in the pole base.

Attach cap to pole with a sturdy chain or cable. Ensure the chain or cable is long enough to permit the cap to hang clear of the opening when the cap is removed.

Perform repair of damaged galvanizing that complies with the *Standard Specifications*, Article 1076-7 "Repair of Galvanizing."

Install galvanized wire mesh around the perimeter of the base plate to cover the gap between the base plate and top of foundation for debris and pest control.

Install a 1/4" thick plate for concrete foundation tag to include: concrete grade, depth, diameter, and reinforcement sizes of the installed foundation.

12.2. METAL POLE UPRIGHTS (VERTICAL MEMBERS)

A. Materials:

- Provide tapered tubular shafts and fabricated of steel conforming to ASTM A-595 Grade A or an approved equivalent.
- Hot-dip galvanize poles in accordance with AASHTO M 111 or an approved equivalent.
- Have shafts that are continuously welded for the entire length by the submerged arc process, and with exposed welds ground or rolled smooth and flush with the base metal. Provide welding that conforms to Article 1072-18 of the *Standard Specification* except that no field welding on any part of the pole will be permitted.
- Have Shafts with no circumferential welds except at the lower end joining the shaft to the base.
- Have anchor bases for steel poles fabricated from plate steel meeting as a minimum the requirements of ASTM A572 Gr 50, AASHTO M270 Gr 50, ASTM A709 Gr 50, or an approved equivalent.

TS-79

Provide a grounding lug(s) in the approximate vicinity of the messenger cable clamp for bonding and grounding messenger cable. Lugs must accept #4 or #6 AWG wire to bond messenger cables to the pole in order to provide an effective ground fault circuit path. Refer to Metal Pole Standard Drawing Sheet M6 for construction details.

Have poles permanently stamped above the hand holes with the identification tag details as shown on Metal Pole Standard Drawing Sheet M2.

Provide liquid tight flexible metal conduit (Type LFMC), liquid tight flexible nonmetallic conduit (Type LFNC), high density polyethylene conduit (Type HDPE), or approved equivalent to isolate conductors feeding luminaires.

Fabricate poles from a single piece of steel or aluminum with single line seam weld with no transverse butt welds. Fabrication of two ply pole shafts is unacceptable with the exception of fluted shafts. Provide tapers for all shafts that begin at base and that have diameters which decrease uniformly at the rate of not more than 0.14 inch per foot (11.7 millimeters per meter) of length.

Provide four anchor nuts and four washers for each anchor bolt. Ensure that anchor bolts have required diameters, lengths, and positions, and will develop strengths comparable to their respective poles.

Provide a terminal compartment with cover and screws in each pole that encompasses the hand hole and contains a 12-terminal barrier type terminal block. Provide two terminal screws with a removable shorting bar between them for each termination. Furnish terminal compartment covers attached to the pole by a sturdy chain or cable approved by the Engineer. Ensure that the chain or cable is long enough to permit the cover to hang clear of the compartment opening when the cover is removed, and is strong enough to prevent vandals from being able to disconnect the cover from the pole. Ensure that the chain or cable will not interfere with service to the cables in the pole base.

Install grounding lugs that will accept #4 or #6 AWG wire to electrically bond messenger cables to the pole. Refer to Metal Pole Standard Drawing Sheet M6 for construction details.

For each pole, provide a 1/2 inch minimum thread diameter, coarse thread stud and nut for grounding which will accommodate #6 AWG ground wire. Ensure that the lug is electrically bonded to the pole and is conveniently located inside the pole at the hand hole.

Provide a removable pole cap with stainless steel attachment screws for the top of each pole. Ensure that the cap is cast aluminum conforming to Aluminum Association Alloy 356.0F. Furnish cap attached to the pole with a sturdy chain or cable approved by the Engineer. Ensure that the chain or cable is long enough to permit the cap to hang clear of the pole-top opening when the cap is removed.

When required by the plans, furnish couplings 42 inches above the bottom of the base for mounting of pedestrian pushbuttons. Provide mounting points consisting of 1-1/2 inch internally threaded half-couplings that comply with the NEC and that are mounted within the poles. Ensure that couplings are essentially flush with the outside surfaces of the poles and are installed before any required galvanizing. Provide a threaded plug in each mounting point. Ensure that the surface of the plug is essentially flush with the outer end of the mounting point when installed and has a recessed hole to accommodate a standard wrench.

TS-80

1. STRAIN POLE SHAFTS

Provide 2 messenger cable (span wire) clamps and associated hardware for attachment of messenger cable. Ensure that diameter of the clamp is appropriate to its location on the pole and is appropriately designed to be adjustable from 1'-6" below the top, down to 6'-6" below the top of the pole. Do not attach more than one support cable to a messenger cable clamp.

Provide a minimum of three (3) 2 inch (50 mm) holes equipped with an associated coupling and weatherhead on the messenger cable load side of the pole to accommodate passage of signal cables from inside the pole. Provide galvanized threaded plugs for all unused couplings at pole entrance points. Refer to Metal Pole Standard Drawing Sheet M3 for fabrication details.

Ensure that allowable pole deflection does not exceed that allowed per 6th Edition AASHTO. Ensure maximum deflection at the top of the pole does not exceed 2.5 percent of the pole height.

2. MAST ARM POLE SHAFTS

Ensure that allowable pole deflection does not exceed that allowed per 6th Edition AASHTO. Ensure that maximum angular rotation of the top of the mast arm pole does not exceed 1 degree 40 minutes (1°40').

B. Construction Methods:

Install metal poles, hardware, and fittings as shown on the manufacturer's installation drawings. Install metal poles so that when the pole is fully loaded it is within 1 degree 40 minutes (1°40') of vertical. Install poles with the manufacturer's recommended "rake." Use threaded leveling nuts to establish rake if required.

12.3. MAST ARMS

Provide pole plates and associated gussets and fittings for attachment of required mast arms. As part of each mast arm attachment, provide a cable passage hole in the pole to allow passage of signal cables from the pole to the arm.

Ensure that allowable mast arm deflection does not exceed that allowed per 6th Edition AASHTO. Also when arm is fully loaded, tip of the arm shall not go below the arm attachment point with the pole for all load conditions per 6th Edition AASHTO.

Furnish all arm plates and necessary attachment hardware, including bolts and brackets.

Provide two extra bolts for each arm.

Provide grommet holes on the arms to accommodate cables for the signals.

Provide arms with weatherproof connections for attaching to the shaft of the pole.

Provide hardware that is galvanized steel, stainless steel, or corrosive-resistant aluminum.

Provide a removable end cap with stainless steel attachment screws for the end of each mast arm. Ensure that the cap is cast aluminum conforming to Aluminum Association Alloy 356.0F. Furnish cap attached to the arm with a sturdy chain or cable approved by the Engineer. Ensure that the chain or cable is long enough to permit the cap to hang clear of the arm end opening when the cap is removed.

Comply with the following for Steel Luminaire Arms:

- In addition to tapered tube, luminaire arms may be standard weight black steel pipe conforming to ASTM A 53-90a, Type E or Type S, Grade B or an approved equivalent.

TS-81

- Conform to the welding requirements of the steel poles.
- After all fabricating, cutting, punching, and welding are completed, luminaire arms should be hot-dipped galvanized inside and outside.
- In accordance with the National Electrical Code (NEC) Article 230.2(E), provide identification of the electrical source provider for the luminaire feeder circuit with contact information on a permanent label located in the pole hand hole in the vicinity of the feeder circuit raceway.

A. Materials:

After all fabricating, cutting, punching, and welding are completed, hot-dip galvanize the structure in accordance with the AASHTO M 111 or an approved equivalent.

B. Construction Methods:

Install horizontal-type arms with sufficient manufactured rise to keep arm from deflecting below the arm attachment height.

Attach cap to the mast arm with a sturdy chain or cable. Ensure that the chain or cable is long enough to permit the cap to hang clear of the arm opening when the cap is removed.

For mast arm poles, use full penetration welds with back-up ring at the pole base and at the arm base connection.

12.4. DRILLED PIER FOUNDATIONS FOR METAL TRAFFIC SIGNAL POLES

Analysis procedures and formulas shall be based on AASHTO 6th Edition, latest ACI code and the *Drilled Shafts: Construction Procedures and Design Methods* FHWA-NHI-10-016 manual. Design methods based on engineering publications or research papers needs to have prior approval from NCDOT. The Department reserves the right to accept or disapprove any method used for the analysis.

Use a Factor of Safety of 1.33 for torsion and 2.0 for bending for the foundation design.

Foundation design for lateral load shall not exceed 1" lateral deflection at top of foundation.

For lateral analysis, use LPILE Plus V6.0 or later. Inputs, results and corresponding graphs are to be submitted with the design calculations.

Skin Friction is to be calculated using the α -method for cohesive soils and the β -method for cohesion-less soils (**Broms method will not be accepted**). Detailed descriptions of the " α " and " β " methods can be found in *FHWA-NHI-10-016*.

Omit first 2.5ft for cohesive soils when calculating skin friction.

When hammer efficiency is not provided, assume a value of 0.70.

Design all custom foundations to carry the maximum capacity of each metal pole. For standard case strain poles only, if a custom foundation is designed, use the actual shear, axial and moment reactions from the Standard Foundation Selection Table shown on Standard Drawing No. M8.

When poor soil conditions are encountered which could create an excessively large foundation design, consideration may be given to allowing an exemption to the maximum capacity design. The contractor must gain approval from the engineer before reducing a foundation's capacity. On projects where poor soil is known to be present, it is advisable that the contractor consider getting foundations approved before releasing poles for fabrication.

TS-82

Have the contractor notify the engineer if the proposed foundation is to be installed on a slope other than 8H: 1V or flatter.

A. Description:

Furnish and install foundations for NCDOT metal poles with all necessary hardware in accordance with the plans and specifications.

Metal Pole Standards have been developed and implemented by NCDOT for use at signalized intersections in North Carolina. If the plans call for a standard pole, then a standard foundation may be selected from the plans. However, the Contractor is not required to use a standard foundation. If the Contractor chooses to design a non-standard site-specific foundation for a standard pole or if the plans call for a non-standard site-specific pole, design the foundation to conform to the applicable provisions in the NCDOT Metal Pole Standard Drawings and Section B7 (Non-Standard Foundation Design) below. If non-standard site specific foundations are designed for standard QPL approved strain poles, the foundation designer must use the design moment specified by load case on Metal Pole Standard Drawing Sheet M8. Failure to conform to this requirement will be grounds for rejection of the design.

If the Contractor chooses to design a non-standard foundation for a standard pole and the soil test results indicate a standard foundation is feasible for the site, the Contractor will be paid the cost of the standard foundation (drilled pier and wing wall, if applicable). Any additional costs associated with a non-standard site-specific foundation including additional materials, labor and equipment will be considered incidental to the cost of the standard foundation. All costs for the non-standard foundation design will also be considered incidental to the cost of the standard foundation.

B. Soil Test and Foundation Determination:

1. General:

Drilled piers are reinforced concrete sections, cast-in-place against in situ, undisturbed material. Drilled piers are of straight shaft type and vertical.

Some standard drilled piers for supporting poles with mast arms may require wing walls to resist torsional rotation. Based upon this provision and the results of the required soil test, a drilled pier length and wing wall requirement may be determined and constructed in accordance with the plans.

For non-standard site-specific poles, the contractor-selected pole fabricator will determine if the addition of wing walls is necessary for the supporting foundations.

2. Soil Test:

Perform a soil test at each proposed metal pole location. Complete all required fill placement and excavation at each signal pole location to finished grade before drilling each boring. Soil tests performed that are not in compliance with this requirement may be rejected and will not be paid. Drill one boring to a depth of 26 feet within a 25 foot radius of each proposed foundation.

Perform standard penetration tests (SPT) in accordance with ASTM D 1586 at depths of 1, 2.5, 5, 7.5, 10, 15, 20 and 26 feet. Discontinue the boring if one of the following occurs:

- A total of 100 blows have been applied in any 2 consecutive 6-in. intervals.
- A total of 50 blows have been applied with < 3-in. penetration.

TS-83

Describe each intersection as the “Intersection of (*Route or SR #*), (*Street Name*) and (*Route or SR #*), (*Street Name*), _____ County, Signal Inventory No. _____”. Label borings with “B- *N, S, E, W, NE, NW, SE or SW*” corresponding to the quadrant location within the intersection. Pole numbers should be made available to the Drill Contractor. Include pole numbers in the boring label if they are available. If they are not available, ensure the boring labels can be cross-referenced to corresponding pole numbers. For each boring, submit a legible (hand written or typed) boring log signed and sealed by a licensed Geologist or Professional Engineer registered in North Carolina. Include on each boring the SPT blow counts and N-values at each depth, depth of the boring, hammer efficiency, depth of water table and a general description of the soil types encountered using the AASHTO Classification System.

3. Standard Foundation Determination:

Use the following method for determining the Design N-value:

$$N_{AVG} = \frac{(N@1' + N@2.5' + \dots + N@Deepest \text{ Boring Depth})}{\text{Total Number of N-values}}$$

$$Y = (N@1')^2 + (N@2.5')^2 + \dots + (N@Deepest \text{ Boring Depth})^2$$

$$Z = (N@1' + N@2.5' + \dots + N@Deepest \text{ Boring Depth})$$

$$N_{STD \text{ DEV}} = \left[\frac{(\text{Total Number of N-values} \times Y) - Z^2}{(\text{Total Number of N-values}) \times (\text{Total Number of N-values} - 1)} \right]^{0.5}$$

Design N-value equals lesser of the following two conditions:

$$N_{AVG} - (N_{STD \text{ DEV}} \times 0.45)$$

Or

$$\text{Average of First Four N-Values} = \frac{(N@1' + N@2.5' + N@5' + N@7.5')}{4}$$

4

Note: If less than 4 N-values are obtained because of criteria listed in Section 2 above, use average of N-values collected for second condition. Do not include the N-value at the deepest boring depth for above calculations if the boring is discontinued at or before the required boring depth because of criteria listed in Section 2 above. Use N-value of zero for weight of hammer or weight of rod. If N-value is greater than 50, reduce N-value to 50 for calculations.

If standard NCDOT strain poles are shown on the plans and the Contractor chooses to use standard foundations, determine a drilled pier length, “L,” for each signal pole from the Standard Foundations Chart (sheet M 8) based on the Design N-value and the predominant soil type. For each standard pole location, submit a completed “Metal Pole Standard Foundation Selection Form” signed by the Contractor’s representative. Signature on form is for verification purposes only. Include the Design N-value calculation and resulting drilled pier length, “L,” on each form.

TS-84

If non-standard site-specific poles are shown on the plans, submit completed boring logs collected in accordance with Section 2 (Soil Test) above along with pole loading diagrams from the plans to the contractor-selected pole fabricator to assist in the pole and foundation design.

If one of the following occurs, the Standard Foundations Chart shown on the plans may not be used and a non-standard foundation may be required. In such case, contact the Engineer.

- The Design N-value is less than 4.
- The drilled pier length, “L”, determined from the Standard Foundations Chart, is greater than the depth of the corresponding boring.

In the case where a standard foundation cannot be used, the Department will be responsible for the additional cost of the non-standard foundation.

Foundation designs are based on level ground around the traffic signal pole. If the slope around the edge of the drilled pier is steeper than 8:1 (H:V) or the proposed foundation will be less than 10 feet from the top of an embankment slope, the Contractor is responsible for providing slope information to the foundation designer and to the Engineer so it can be considered in the design.

The “Metal Pole Standard Foundation Selection Form” may be found at:

<http://www.ncdot.gov/doh/preconstruct/highway/geotech/formdet/misc/MetalPole.pdf>

If assistance is needed, contact the Engineer.

4. Non-Standard Foundation Design:

Design non-standard foundations based upon site-specific soil test information collected in accordance with Section 2 (Soil Test) above. Design drilled piers for side resistance only in accordance with Section 4.6 of the *AASHTO Standard Specifications for Highway Bridges*. Use the computer software LPILE version-6.0 or later manufactured by Ensoft, Inc. to analyze drilled piers. Use the computer software gINT V8i or later manufactured by Bentley Systems, Inc. with the current NCDOT gINT library and data template to produce SPT boring logs. Provide a drilled pier foundation for each pole with a length and diameter that result in a horizontal lateral movement of less than 1 inch at the top of the pier and a horizontal rotational movement of less than 1 inch at the edge of the pier. Contact the Engineer for pole loading diagrams for standard poles to be used for non-standard foundation designs. Submit any non-standard foundation designs including drawings, calculations, and soil boring logs to the Engineer for review and approval before construction.

C. Drilled Pier Construction:

Construct drilled pier foundations in accordance with the *Foundations and Anchor Rod Assemblies for Metal Poles* provision.

12.5. CUSTOM DESIGN OF TRAFFIC SIGNAL SUPPORTS

A. General:

Design traffic signal supports with foundations consisting of metal strain poles or metal poles with mast arms.

The lengths of the metal signal poles shown on the plans are estimated from available data for bid purposes. Determine the actual length of each pole from field measurements and adjusted cross-sections. Furnish the revised pole heights to the Engineer. Use all other dimensional requirements shown on the plans.

TS-85

Ensure each pole includes an identification tag with information and location positions as defined on Metal Pole Standard Drawing Sheets M2, M3 and M4. All pole shaft tags must include the NCDOT Inventory number followed by the pole number shown on the traffic signal or ITS (non-signalized locations) plan.

Design all traffic signal support structures using the following 6th Edition AASHTO specifications:

- Design for a 50 year service life as recommended by Table 3.8.3-2.
- Use the wind pressure map developed from 3-second gust speeds, as provided in Article 3.8.
- Ensure signal support structures include natural wind gust loading and truck-induced gust loading in the fatigue design, as provided for in Articles 11.7.1.2 and 11.7.1.3, respectively. Designs need not consider periodic galloping forces.
- Assume the natural wind gust speed in North Carolina is 11.2 mph. For natural wind fatigue stress calculations, utilize a drag coefficient (C_d) computed for 11.2 mph wind velocity and not the basic wind speed velocity.
- Design for Category II fatigue, as provided for in Article 11.6, unless otherwise specified.
- Calculate all stresses using applicable equations from Section 5. The Maximum allowable stress ratios for all signal support designs are 0.9.
- Conform to article 10.4.2 and 11.8 for all deflection requirements.

Ensure that the design permits cables to be installed inside poles and mast arms.

Unless otherwise specified by special loading criteria, the computed surface area for ice load on signal heads is:

- 3-section, 12-inch, Surface area: 26.0 ft² (17.0 ft² without back plate)
- 4-section, 12-inch, Surface area: 32.0 ft² (21.0 ft² without back plate)
- 5-section, 12-inch, Surface area: 42.0 ft² (29.0 ft² without back plate)

The ice loading for signal heads defined above includes the additional surface area that back plates will induce. Special loading criteria may be specified in instances where back plates will not be installed on signal heads. Refer to the Loading Schedule on each Metal Pole Loading Diagram for revised signal head surface areas. The pole designer should revise ice loads accordingly in this instance. Careful examination of the plans when this is specified is important as this may impact sizing of the metal support structure and foundation design which could affect proposed bid quotes. All maximum stress ratios of 0.9 still apply.

Assume the combined minimum weight of a messenger cable bundle (including messenger cable, signal cable and detector lead-in cables) is 1.3 lbs/ft. Assume the combined minimum diameter of this cable bundle is 1.3 inches.

Ensure that designs provide a removable pole cap with stainless steel attachment screws for each pole top and mast arm end.

B. Metal Poles:

Submit design drawings for approval including pre-approved QPL pole drawings. Show all the necessary details and calculations for the metal poles including the foundation and connections. Include NCDOT inventory number on design drawings. Include as part of the design calculations the

TS-86

ASTM specification numbers for the materials to be used. Provide the types and sizes of welds on the design drawings. Include a Bill of Materials on design drawings. Ensure design drawings and calculations are signed, dated, and sealed by the responsible professional engineer licensed in the state of North Carolina. Immediately bring to the attention of the Engineer any structural deficiency that becomes apparent in any assembly or member of any assembly as a result of the design requirements imposed by these specifications, the plans, or the typical drawings. Said Professional Engineer is wholly responsible for the design of all poles and arms. Review and acceptance of these designs by the Department does not relieve the said Professional Engineer of his responsibility. **Do not fabricate the assemblies until receipt of the Department's approval of the design drawings.**

For mast arm poles, provide designs with provisions for pole plates and associated gussets and fittings for mast arm attachment. As part of each mast arm attachment, provide a grommeted 2" diameter hole on the shaft side of the connection to allow passage of the signal cables from the pole to the arm.

Where ice is present, assume wind loads as shown in Figure 3.9.4.2-3 of the 6th Edition AASHTO Specification for Group III loading.

For each strain pole, provide two messenger cable clamps and associated hardware to attach the messenger support cable. Ensure that the diameter of the clamps is appropriately designed to be adjustable from 1'-6" inches below the top, down to 6'-6" below the top of the pole. Do not attach more than one messenger support cable to a messenger cable clamp.

Provide a grounding lug(s) in the approximate vicinity of the messenger cable clamp for bonding and grounding messenger cable. Lugs must accept #4 or #6 AWG wire to bond messenger cables to the pole in order to provide an effective ground fault circuit path. Refer to Metal Pole Standard Drawing Sheet M6 for construction details.

Design tapers for all pole shafts that begin at the base with diameters that decrease uniformly at the rate of 0.14 inch per foot of length.

Design a base plate on each pole. The minimum base plate thickness for all poles is determined by the following criteria:

Case 1 Circular or rectangular solid base plate with the upright pole welded to the top surface of base plate with full penetration butt weld, and where no stiffeners are provided. A base plate with a small center hole, which is less than 1/3 of the upright diameter, and located concentrically with the upright pole, may be considered as a solid base plate.

The magnitude of bending moment in the base plate, induced by the anchoring force of each anchor bolt is $M = (P \times D_1) / 2$, where

M = bending moment at the critical section of the base plate induced by one anchor bolt

P = anchoring force of each anchor bolt

D₁ = horizontal distance between the anchor bolt center and the outer face of the upright, or the difference between the bolt circle radius and the outside radius of the upright

Locate the critical section at the face of the anchor bolt and perpendicular to the bolt circle radius. The overlapped part of two adjacent critical sections is considered ineffective.

TS-87

Case 2 Circular or rectangular base plate with the upright pole socketed into and attached to the base plate with two lines of fillet weld, and where no stiffeners are provided, or any base plate with a center hole that is larger in diameter than 1/3 of the upright diameter.

The magnitude of bending moment induced by the anchoring force of each anchor bolt is $M = P \times D_2$,

where P = anchoring force of each anchor bolt

D_2 = horizontal distance between the face of the upright and the face of the anchor bolt nut

Locate the critical section at the face of the anchor bolt top nut and perpendicular to the radius of the bolt circle. The overlapped part of two adjacent critical sections is considered ineffective.

If the base plate thickness calculated for Case 2 is less than Case 1, use the thickness calculated for Case 1.

The following additional owner requirements apply concerning pole base plates.

- Ensure that whichever case governs as defined above, the anchor bolt diameter is set to match the base plate thickness. If the minimum diameter required for the anchor bolt exceeds the thickness required for the base plate, set the base plate thickness equal to the required bolt diameter.
- For dual mast arm supports, or for single mast arm supports 50' or greater, use a minimum 8 bolt orientation with 2" diameter anchor bolts, and a 2" thick base plate.
- For all metal poles with mast arms, use a full penetration groove weld with a backing ring to connect the pole upright component to the base. Refer to Metal Pole Standard Drawing Sheet M4.

Ensure that designs have anchor bolt holes with a diameter 1/4 inch larger than the anchor bolt diameters in the base plate.

Ensure that the anchor bolts have the required diameters, lengths, and positions, and will develop strengths comparable to their respective poles.

Provide designs with a 6 x 12-inch hand hole with a reinforcing frame for each pole.

Provide designs with a terminal compartment with cover and screws in each pole that encompasses the hand hole and contains provisions for a 12-terminal barrier type terminal block.

For each pole, provide designs with provisions for a 1/2 inch minimum thread diameter, coarse thread stud and nut for grounding which will accommodate a #6 AWG ground wire. Ensure the lug is electrically bonded to the pole and is conveniently located inside the pole at the hand hole.

When required, design couplings on the pole for mounting pedestrian pushbuttons at a height of 42 inches above the bottom of the base. Provide mounting points consisting of 1-1/2 inch internally threaded half-couplings that comply with the NEC that are mounted within the poles. Ensure the couplings are essentially flush with the outside surfaces of the poles and are installed before any required galvanizing. Provide a threaded plug for each half coupling. Ensure that the surface of the plug is essentially flush with the outer end of the mounting point when installed and has a recessed hole to accommodate a standard wrench.

TS-88

C. Mast Arms:

Design all arm plates and necessary attachment hardware, including bolts and brackets as required by the plans.

Design for grommets holes on the arms to accommodate the cables for the signals if specified.

Design arms with weatherproof connections for attaching to the shaft of the pole.

Always use a full penetration groove weld with a backing ring to connect the mast arm to the pole. Refer to Metal Pole Standard Drawing Sheet M5.

Capacity of tapped flange plate must be sufficient to develop the full capacity of the connecting bolts. In all cases the flange plate of both arm and shaft must be at least as thick as the arm connecting bolts are in diameter.

12.6. METAL SIGNAL POLE REMOVALS

A. Description:

Remove and dispose of existing metal signal poles including mast arms, and remove and dispose of existing foundations, associated anchor bolts, electrical wires and connections.

B. Construction Methods:

1. Foundations:

Remove and promptly dispose of the metal signal pole foundations including reinforcing steel, electrical wires, and anchor bolts to a minimum depth of two feet below the finished ground elevation. At the Contractor's option, remove the complete foundation.

2. Metal Poles:

Assume ownership of the metal signal poles, remove the metal signal poles, and promptly transport the metal signal poles from the project. Use methods to remove the metal signal poles and attached traffic signal equipment that will not result in damage to other portions of the project or facility. Repair damages that are a result of the Contractor's actions at no additional cost to the Department.

Transport and properly dispose of the materials.

Backfill and compact disturbed areas to match the finished ground elevation. Seed unpaved areas.

Use methods to remove the foundations that will not result in damage to other portions of the project or facility. Repair damages that are a result of the Contractor's actions at no cost to the Department.

12.7. POLE NUMBERING SYSTEM

A. New Poles

Attach an identification tag to each pole shaft and mast arm section as shown on Metal Pole Standard Drawing Sheet M2 "Typical Fabrication Details Common To All Metal Poles".

TS-89

B. Reused Poles

Do not remove the original identification tag(s) from the pole shaft and/or mast arm sections. Add a new identification tag based on the new location for any reused poles and/or mast arms.

12.8. REUSED POLE SHAFTS AND/OR MAST ARMS

Provide shop drawings along with new foundation designs for review and approval prior to furnishing and/or installing any reused metal poles and/or mast arms. Use the same requirements as specified for new materials as stated above in these Special Provisions.

For reused pole shaft and mast arm combinations, it is preferable to use the original shafts and arms that were used together at the time of original installation.

12.9. MEASUREMENT AND PAYMENT

Actual number of metal strain signal poles (without regard to height or load capacity) furnished, installed and accepted.

Actual number of metal poles with single mast arms furnished, installed, and accepted.

Actual number of metal poles with dual mast arms furnished, installed, and accepted.

Actual number of reused metal strain signal poles (without regard to height or load capacity) furnished, installed and accepted.

Actual number of reused metal strain signal poles (without regard to height or load capacity) installed and accepted.

Actual number of reused metal poles with single mast arms furnished, installed, and accepted.

Actual number of reused metal poles with single mast arms installed and accepted.

Actual number of reused metal poles with dual mast arms furnished, installed, and accepted.

Actual number of reused metal poles with dual mast arms installed and accepted.

Actual number of soil tests with SPT borings drilled furnished and accepted.

Actual volume of concrete poured in cubic yards of drilled pier foundation furnished, installed and accepted.

Actual number of foundations with wing walls furnished, installed and accepted, excluding foundation length. Refer to method of measurement above for drilled pier foundation.

Actual number of designs for metal strain poles furnished and accepted.

Actual number of designs for mast arms with metal poles furnished and accepted.

Actual number of metal signal pole foundations removed and disposed.

Actual number of metal signal poles removed and disposed.

No measurement will be made for foundation designs prepared with metal pole designs, as these will be considered incidental to designing signal support structures.

Payment will be made under:

Metal Strain Signal PoleEach
Metal Pole with Single Mast ArmEach

TS-90

Metal Pole with Dual Mast Arm.....	Each
Furnish and Install Reused Metal Strain Signal Pole.....	Each
Install Reused Metal Strain Signal Pole.....	Each
Furnish and Install Reused Metal Pole with Single Mast Arm.....	Each
Install Reused Metal Pole with Single Mast Arm.....	Each
Furnish and Install Reused Metal Pole with Dual Mast Arm.....	Each
Install Reused Metal Pole with Dual Mast Arm.....	Each
Soil Test.....	Each
Drilled Pier Foundation.....	Cubic Yard
Foundation with Wing Walls (_____).....	Each
Metal Strain Pole Design.....	Each
Mast Arm with Metal Pole Design.....	Each
Metal Pole Foundation Removal.....	Each
Metal Pole Removal.....	Each

13. PROTECTIVE COATING FOR METAL POLES

13.1. Description

Protective coating for metal poles is a supplemental durable color coating that is applied to galvanized steel and aluminum traffic signal structures installed in locations where maintaining an aesthetic appearance is important. Powder Coating is the preferred supplemental protective coating process for coating galvanized steel and aluminum structures. However, for the purposes of this special provision, an Acrylic Primer and top coat paint system is included as an acceptable alternative when protective color coating is required.

Provide protective coating over galvanization for all steel poles including all necessary hardware in accordance with the plans and specifications. Any aluminum components do not need to be galvanized before application of protective coating.

13.2. Materials

With the exception of aluminum components, furnish all metal poles with galvanic protection along with a tough and durable application of protective coating. Aluminum components shall have a durable powder coating application. Galvanization is not required for aluminum components.

Furnish pole caps that have a low gloss powder finish applied over a hot-dipped galvanized surface. Comply with the applicable provisions of Section 442-10 and 442-12 of the *Standard Specifications*.

Ensure the selected color for protective coating has been verified and approved by the Engineer prior to fabrication.

13.3. Coating Shop Approval

Approve the coating shop facility prior to the application of any coating process. Submit all requests, procedures and documents electronically to:

- Mr. Brian Hunter, P.E., Chemical Testing Engineer
 - bhunter@ncdot.gov
- A) Submit a quality control procedure that the company has established to ensure a quality and durable coating. The quality control procedure shall contain at a minimum the following:

TS-91

- Qualified / Certified personnel to manage the QC Program and to conduct Quality Control tests
 - Qualified / certified coaters
 - Source and type of powder
 - How the powder will be stored
 - Powder application facility (heated or unheated)
 - Surface pre-treatment
 - Surface preparation including profile
 - Application methods
 - Curing conditions (conventional or infrared)
 - Curing Temperature
 - Adhesion & Holiday Detection
 - Repair Procedure
 - Storage and protection of coated items
 - Shipping and handling (packing, protection, and wrapping)
- B) Submit a powder certification from the manufacturer
- C) Submit the following to the Chemical Testing Engineer a minimum of four weeks prior to coating application.
1. Two test panels of ASTM A36 steel, $\frac{1}{4}$ or greater in thickness measuring 8 inches by 11 inches using the proposed color of the final coat; a powder coated over galvanized test panel and a powder coated over un-galvanized test panel.
 2. In addition, provide two (2) samples of the same or comparable material and thickness as production pieces. Ensure production piece replicas do not exceed twelve inches (12”) in length and width nor 50 pounds in weight.
 3. Submit all test panels with inspection reports and records according to *Standard Specifications*, Section 442, Section 1072, Section 1076, and Section 1080.
 4. Acceptance of the panels is determined by meeting the requirements of ASTM D-4541 of 800 psi for both galvanized and un-galvanized and production piece test panels.
 5. Send all panels to :
Materials and Tests Unit
1801 Blue Ridge Road
Raleigh, NC 27607
Attn: Chemical Testing Engineer

13.4. POWDER COATING

A. Galvanizing

Galvanize steel products in accordance with Section 1076 of the *Standard Specifications*. Ensure the fabricator or designated representative(s) that is supplying the components to be galvanized communicates with the galvanizer to indicate that the galvanized pieces will be powder coated to avoid water or chromate quenching.

TS-92

B. Surface Preparation

Comply with manufacturer's recommended surface coating specifications, Steel Structure Painting Council (SSPC) specifications and applicable articles of Section 442 (Painting Steel Structures) of the *Standard Specifications*. Ensure that surface preparations and treatments are performed and meet the requirements of the above referenced specifications.

Some pole components, specifically steel plates $\frac{3}{4}$ inches or more in thickness, may need blast cleaning prior to structure assembly to remove impurities and non-metallic foreign materials. Mechanically remove all weld flux after structure is assembled

Degrease and prepare steel structure for zinc coating after assembly using full immersion baths and pickling processes in heat controlled caustic and acid solutions. Rinse and clean structure to remove caustic or acid solutions by immersion in a circulating fresh water bath. Immerse structure in a heat controlled concentrated zinc ammonium chloride flux solution and air dry as a final prep before hot-dip galvanization.

Ensure that the surface preparation is no less than specified by the powder manufacturer's recommendations. Prepare all components to be coated in accordance with SSPC SP-2 (Hand Tool Cleaning) and/or SSPC SP-3 (Power Tool Cleaning). Remove all drainage spikes, high spots, protrusions or other surface defects using hand or power tools. Do not remove the galvanization below the limits set forth in AASHTO M111.

Remove grease, oils, moisture, scale, rust or any other foreign matter prior to powder coating to ensure ideal adhesion and coating performance. Prepare and coat the galvanized surface as soon as possible after the galvanization process.

C. Powder Coating Application and Curing

Prepare galvanized finish for powder coating by brush blasting in accordance with SSPC-SP7. Ensure all threaded components of the structure are protected from damage during blasting process.

Use thermosetting powder resin that meets 5A or 5B classifications of ASTM D3359. Apply powder coating electrostatically. Follow manufacturer's recommended preheating requirements. Ensure the top coat finish is applied uniformly to all surfaces with a dry film thickness of between 3.0 to 5.0 mils. Cure the top coat by heating the structure to manufacturer recommended temperatures at the duration required to ensure complete and uniform bond.

D. Quality Control

Ensure the applicator provides all test reports and documentation and inspects all coated material as outlined in the *Standard Specifications*, Section 442, Section 1072, Section 1076, and Section 1080. Ensure the quality control inspection is kept separate from the production functions.

E. Storage, Shipping, and Handling

Store all powder coated material inside or as directed by the Engineer.

Protect the product from incurring damage during all shipping, handling, and storing activities. Do not store the product directly on the ground or in areas where water may

TS-93

pool; the Engineer determines the effectiveness of all storage, shipping and handling methods.

F. Repair of Powder Coated Material

Repair all damage to the coating by the original method of application as outlined in the coating facility's repair procedure. Ensure all repair areas meet the original requirements for adhesion as stated in this Project Special Provision.

Photograph, document, and report all damages upon delivery to the project site prior to unloading. Provide documented damage notifications to the Engineer or to their authorized representative so the application firm can be notified. The Engineer has the authority to accept or reject the material as outlined in the *Standard Specifications*.

Submit to the Engineer a repair procedure for damaged coatings which occur during storage, transporting, handling and or installation. Utilize a liquid paint approved by the Department, compatible with the powder applied product. Ensure all repair areas demonstrate an adhesion rating of 400 psi in accordance with ASTM D-4541. Obtain Engineer's acceptance of the final finish.

13.5. ACRYLIC PRIMER AND TOP COAT PAINT SYSTEM 4 (MODIFIED)

A. Description

Follow NCDOT procedures for Powder Coating over Galvanizing. Provide an Acrylic Primer and top coat when a substitute for powder coating is necessary.

Provide supplemental coating for all mast arms with metal signal poles and all necessary hardware for the signalized intersection in accordance with NCDOT Standard specifications – sections 442 and 1080, as contained herein, and as shown on the plans.

Ensure all painting work for new structures, except field touch-up and bolt painting is performed in the shop.

B. Surface Preparation

Ensure all surface preparation is not less than that specified by the paint manufacturer's recommendations.

Ensure all components to be coated are prepared in accordance with SSPC SP2 (Hand Tool Cleaning and or SSPC SP-3 (Power Tool Cleaning). Remove all drainage spikes, high spots, protrusions or other surface defects using hand or power tools. Do not remove the galvanization below the limits set forth in AASHTO M111.

Perform abrasive sweep blasting in accordance with ASTM D6386. Refer to this section for a description of the abrasive blast material to be used. Use a material and technique capable of stripping action to remove corrosion products and to provide a rough surface profile while leaving base zinc layers intact.

Blow down all blasted surfaces with clean compressed air to provide a clean, dry surface.

TS-94

Ensure all surfaces are free of visible zinc oxides or zinc hydroxides.

C. Materials

Use an approved/qualified waterborne paint meeting the requirements of NCDOT Standard specification section 1080. Do not apply paint until each batch has been tested by the Department. Provide color as specified in the contract documents.

Ensure all paint used on this contract is produced by the same manufacturer.

D. Painting

Apply paint in accordance with the requirements of Section 1080 and Section 442 of the 2010 *Standard Specifications* using System 4 as modified herein.

System 4 (Modified) Acrylic Primer and Top Coats

Coat	Material	Mils Dry/Wet Film Thickness	Mils Dry/Wet Film Thickness
		Minimum	Maximum
Primer	1080-12 White	3.0 DFT	5.0 DFT
Stripe	1080-12 Brown	4.0 WFT	7.0 WFT
Topcoat	1080-12 Brown	2.0 DFT	4.0 DFT
Total		5.0 DFT	9.0 DFT

Shop paint all galvanized surfaces within 8 hours after surface preparation with the exception of field touch-up and bolt painting.

Mask off and do not paint all data plates and faying surfaces prior to application.

Spray apply all coatings except for the stripe coat. Brush apply the stripe coat to all plate edges, welds, bolt holes and bolts prior to applying the finish coat.

E. Curing

Store all material in a heated shop for a period no less than 24 hours once top coat has been applied. Continue storing material until requirements of ASTM D-1640 have been met.

F. Inspection

Provide inspection records showing the initial average thickness of the hot dipped galvanizing as well as the final average DFT measurement.

Ensure all material is of a uniform appearance free of runs, drips, and sags.

G. Handling

Do not handle, ship, or erect coated members until paint is thoroughly dry.

TS-95

Protect all shipping and handling either from the coating facility to project site and or storage site to area(s) to construction location from incurring damage to product. Wood blocks and nylon slings are recommended for securing, loading, hoisting or storing members.

H. Repair of Damaged Coating

Repair damage occurring to the galvanized portion of the coating during shipment or installation in accordance with Articles 1076-6 and 1080-9 of the *Standard Specifications*. Repair damage occurring to the painted portion of the coating during shipment or installation by applying 4.0-7.0 wet mils of topcoat with a brush or roller and feather or taper this to be level with the surrounding areas.

13.6. MEASUREMENT AND PAYMENT

Actual number of strain poles with protective coating applied furnished, installed, and accepted.

Actual number of single mast arm poles with protective coating applied furnished, installed, and accepted.

Actual number of dual mast arm poles with protective coating applied furnished, installed, and accepted.

Actual number of signal pedestals with protective coating applied furnished, installed, and accepted.

Actual number of pushbutton posts with protective coating applied furnished, installed, and accepted.

Payment will be made under:

Protective Coating for Strain Pole (_____)	Each
Protective Coating for Single Mast Arm Pole (_____)	Each
Protective Coating for Dual Mast Arm Pole (_____)	Each
Protective Coating for Signal Pedestal (_____)	Each
Protective Coating for Pushbutton Post (_____)	Each

14. JUNCTION BOX MARKERS

14.1. DESCRIPTION

Furnish and install junction box markers with all necessary hardware and adhesives to warn of buried fiber-optic communications cable.

14.2. MATERIALS

A. Junction Box Markers

Furnish durable, non-reflective junction box markers, also known as curb markers, fabricated from UV-resistant, non-metallic materials other than ceramic material, such as polyurethane or high impact polypropylene or other high impact plastic. Provide junction box markers that are designed for outdoor use, that are waterproof, that resist fading, that are temperature stable and that resist chemical and mechanical abrasion. Furnish junction box markers with a quick-setting adhesive designed for use with the junction box markers supplied and designed to permanently adhere

TS-96

junction box markers to Portland cement/concrete, steel, and cast iron as well as other non-porous hard surfaces. Do not provide markers that require intrusive fasteners to secure the marker to the surface. Do not provide adhesives that are not designed for use with the junction markers supplied. Provide junction box markers that do not require special tools such as torches, tamping machines or drills or hardware or special surface preparation for installation. Furnish junction box markers from a manufacturer that has been producing such junction box markers (i.e., curb markers) for a minimum of 10 consecutive years.

Order the junction box marker with the Division's Phone Number printed on the marker, hand written sharpie labeling is not acceptable. Consult with the Engineer to ensure the junction box labels are ordered with the correct Division phone number. Provide junction box markers that contain the text and symbols, text emphasis and text proportions depicted in the example format shown below.:

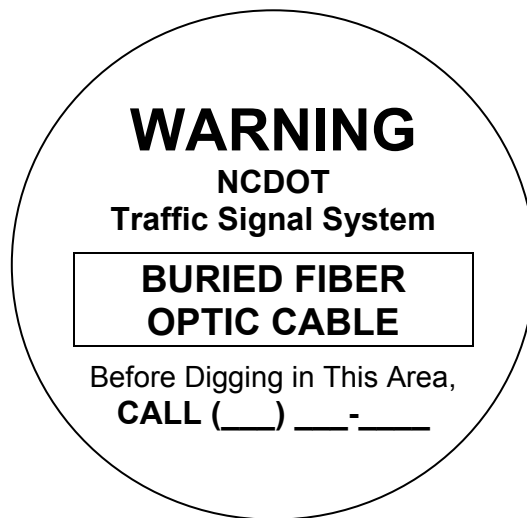

Overall Junction Box Marker Dimensions: 2.5" diameter

Text: Black

Background: Light Gray (to blend with concrete and granite surfaces)

Submit samples of proposed junction marker to the Engineer for approval before installation. In lieu of designing a custom junction box marker, the Contractor may submit for the Engineer's approval a stock/standard junction box marker format (i.e., off-the-shelf format) from the junction box marker manufacturer that differs from the example format proposed above but that still embodies the content and intent conveyed by the example format.

Have the junction box marker manufacturer provide a list of references along with contract information for at least five different municipal government agencies and/or state departments of transportation that have installed the proposed manufacturer's markers and can attest to the performance of the manufacturer's markers over a continuous period of no less than seven years. Submit these references to the Engineer for review in conjunction with submission of the sample.

TS-97

14.3. CONSTRUCTION METHODS

B. Junction Box Markers

Apply junction box markers to the surface of the junction box cover/lid on all new and/or existing junction boxes that are to be reused to house the fiber-optic communications cable. Additionally, at locations where a junction box is perpendicular to a raised curb place an additional junction box marker on the curb.

Clean surface to which the junction box marker will be applied. Make sure application surface is dry and free of any loose debris or cracks. Apply adhesive to back side of the junction box marker in accordance with manufacturer’s instructions. Apply additional adhesive when surface is uneven or textured to fill voids and assure secure adhesion. Apply the junction box marker to the application surface and press firmly. Ensure that entire edge around perimeter of marker is sealed to the application surface.

Position the marker in the approximate center of the junction box cover and orient the marker so that its text is parallel to long side of the cover. On curb sections install the marker on the flattest surface of the curb at a point that is perpendicular to the junction box.

Junction box markers are not required to be placed on flat surfaces of the roadway where there is no curbing, unless required by the Engineer.

14.4. MEASUREMENT AND PAYMENT

Junction Box Marker will be measured and paid for as the actual number of junction box markers furnished, installed, and accepted.

No measurement will be made of junction box marker adhesive as this will be considered incidental to furnishing and installing the junction box marker.

Payment will be made under:

Junction Box Marker.....Each

15. BACK PULL FIBER OPTIC CABLE

15.1. DESCRIPTION

Back pull and store or back pull and reinstall existing communications cable.

15.2. CONSTRUCTION

During project construction where instructed to back pull existing aerial sections of fiber optic communications cable, de-lash the cable from the messenger cable and back pull the cable to a point where it can be stored or re-routed as shown on the plans. If instructed, remove and discard the existing messenger cable and pole mounting hardware once the cable is safely out of harm’s way.

During project construction where instructed to back pull existing underground sections of fiber optic communications cable, back pull the cable to a point where it can be stored or re-routed as shown on the plans. If instructed, remove abandoned junction boxes and backfill with a suitable material to match the existing grade. Leave abandoned conduits in place unless otherwise noted.

Where instructed, re-pull the fiber optic cable back along messenger cable or through conduit systems.

TS-98

15.3. MEASUREMENT AND PAYMENT

Back Pull Fiber Optic Cable will be paid for as the actual linear feet of fiber optic cable back pulled and either stored or back pulled and rerouted. Payment is for the actual linear feet of cable back pulled.

No payment will be made for removing messenger cable and pole mounting hardware or removing junction boxes and back filling to match the surrounding grade as these items of work will be considered incidental to back pulling the fiber optic cable.

Payment will be made under:

Back Pull Fiber Optic Cable Linear Feet

16. SPLICE CABINET (FIBER OPTICS)

16.1. DESCRIPTION

Furnish and install splice cabinets and all necessary hardware in accordance with the plans and specifications for the purpose of splicing and terminating fiber-optic cable.

16.2. MATERIALS

Furnish NEMA Type 4 splice cabinets of sufficient size to accommodate the fiber-optic interconnect center. Provide sufficient size so that the equipment installed will not occupy more than 60 percent of the total cabinet volume.

16.3. CONSTRUCTION METHODS

A. General:

Locate cabinets so as not to obstruct sight distance of vehicles turning on red.

B. Pole Mounted:

Install pole-mounted splice cabinets. Install cabinets approximately five feet from the ground line to the top of the cabinet. Secure the cabinet to the pole using an approved installation method.

C. Base Mounted:

Install base mounted cabinets as shown on the plans and as approved by the Engineer. Refer to Section 1750 - Signal Cabinet Foundations of the *Standard Specifications* for installation requirements for the foundations. The following exceptions are made:

- Install only the required number of conduits as shown on the plans plus one additional spare stub out conduit.
- Do not provide a 24-inch working area on the backside of the cabinet. Provide only a 24-inch working area measured from the front of the cabinet and 3 inch lip measured from the sides and back of the cabinet.
- All other requirements apply.

16.4. MEASUREMENT AND PAYMENT

Actual number of fiber-optic splice cabinets (pole mounted) furnished, installed, and accepted.

Actual number of fiber-optic splice cabinets (base mounted) furnished, installed, and accepted.

TS-99

No measurement will be made for the cabinet foundation as it will be covered under Section 1750 – Signal Cabinet Foundations of the *Standard Specifications*.

Payment will be made under:

Fiber-optic Splice Cabinet (_____).....Each

17. ETHERNET EDGE SWITCH

Furnish and install a managed Ethernet edge switch as specified below that is fully compatible, interoperable, and completely interchangeable and functional within the existing City or Division traffic signal system communications network.

17.1. DESCRIPTION

A. Ethernet Edge Switch:

Furnish and install a hardened, field Ethernet edge switch (hereafter “edge switch”) for traffic signal controllers as specified below. Ensure that the edge switch provides wire-speed, fast Ethernet connectivity at transmission rates of 100 megabits per second from each remote ITS device location to the routing switches.

Contact the City or Division to arrange for the programming of the new Field Ethernet Switches with the necessary network configuration data, including but not limited to, the Project IP Address, Default Gateway, Subnet Mask and VLAN ID information. Provide a minimum five (5) days working notice to allow the City or Division to program the new devices.

B. Network Management:

Ensure that the edge switch is fully compatible with the City’s or Division’s existing Network Management Software.

17.2. MATERIALS

A. General:

Ensure that the edge switch is fully compatible and interoperable with the trunk Ethernet network interface and that the edge switch supports half and full duplex Ethernet communications.

Furnish an edge switch that provide 99.999% error-free operation, and that complies with the Electronic Industries Alliance (EIA) Ethernet data communication requirements using single-mode fiber-optic transmission medium and copper transmission medium. Ensure that the edge switch has a minimum mean time between failures (MTBF) of 10 years, or 87,600 hours, as calculated using the Bellcore/Telcordia SR-332 standard for reliability prediction.

B. Compatibility Acceptance

The Engineer has the authority to require the Contractor to submit a sample Field Ethernet Switch and Field Ethernet Transceiver along with all supporting documentation, software and testing procedures to allow a compatibility acceptance test be performed prior to approving the proposed Field Ethernet Switch and Field Ethernet Transceiver for deployment. **The Compatibility**

TS-100

Acceptance testing will ensure that the proposed device is 100% compatible and interoperable with the existing City Signal System network, monitoring software and Traffic Operations Center network hardware. Allow fifteen (15) working days for the Compatibility Acceptance Testing to be performed

C. Standards:

Ensure that the edge switch complies with all applicable IEEE networking standards for Ethernet communications, including but not limited to:

- IEEE 802.1D standard for media access control (MAC) bridges used with the Spanning Tree Protocol (STP);
- IEEE 802.1Q standard for port-based virtual local area networks (VLANs);
- IEEE 802.1P standard for Quality of Service (QoS);
- IEEE 802.1w standard for MAC bridges used with the Rapid Spanning Tree Protocol (RSTP);
- IEEE 802.1s standard for MAC bridges used with the Multiple Spanning Tree Protocol;
- IEEE 802.1x standard for port based network access control, including RADIUS;
- IEEE 802.3 standard for local area network (LAN) and metropolitan area network (MAN) access and physical layer specifications;
- IEEE 802.3u supplement standard regarding 100 Base TX/100 Base FX;
- IEEE 802.3x standard regarding flow control with full duplex operation; and
- IFC 2236 regarding IGMP v2 compliance.
- IEEE 802.1AB Link Layer Discovery Protocol (LLDP)
- IEEE 802.3ad Ethernet Link Aggregation
- IEEE 802.3i for 10BASE-T (10 Mbit/s over Fiber-Optic)
- IEEE 802.3ab for 1000BASE-T (1Gbit/s over Ethernet)
- IEEE 802.3z for 1000BASE-X (1 Gbit/s Ethernet over Fiber-Optic)

D. Functional:

Ensure that the edge switch supports all Layer 2 management features and certain Layer 3 features related to multicast data transmission and routing. These features shall include, but not be limited to:

- An STP healing/convergence rate that meets or exceeds specifications published in the IEEE 802.1D standard.
- An RSTP healing/convergence rate that meets or exceeds specifications published in the IEEE 802.1w standard.
- An Ethernet edge switch that is a port-based VLAN and supports VLAN tagging that meets or exceeds specifications as published in the IEEE 802.1Q standard, and has a minimum 4-kilobit VLAN address table (254 simultaneous).
- A forwarding/filtering rate that is a minimum of 14,880 packets per second for 10 megabits per second and 148,800 packets per second for 100 megabits per second.
- A minimum 4-kilobit MAC address table.
- Support of Traffic Class Expediting and Dynamic Multicast Filtering.

TS-101

- Support of, at a minimum, snooping of Version 2 & 3 of the Internet Group Management Protocol (IGMP).
- Support of remote and local setup and management via telnet or secure Web-based GUI and command line interfaces.
- Support of the Simple Network Management Protocol version 3 (SNMPv3). Verify that the Ethernet edge switch can be accessed using the resident EIA-232 management port, a telecommunication network, or the Trivial File Transfer Protocol (TFTP).
- Port security through controlling access by the users. Ensure that the Ethernet edge switch has the capability to generate an alarm and shut down ports when an unauthorized user accesses the network.
- Support of remote monitoring (RMON-1 & RMON-2) of the Ethernet agent.
- Support of the TFTP and SNTP. Ensure that the Ethernet edge switch supports port mirroring for troubleshooting purposes when combined with a network analyzer.

E. Physical Features:

Ports: Provide 10/100/1000 Mbps auto-negotiating ports (RJ-45) copper Fast Ethernet ports for all edge switches. Provide auto-negotiation circuitry that will automatically negotiate the highest possible data rate and duplex operation possible with attached devices supporting the IEEE 802.3 Clause 28 auto-negotiation standard.

Optical Ports: Ensure that all fiber-optic link ports operate at 1310 or 1550 nanometers in single mode. Provide Type LC connectors for the optical ports, as specified in the Plans or by the Engineer. Do not use mechanical transfer registered jack (MTRJ) type connectors.

Provide an edge switch having a minimum of two optical 100/1000 Base X ports capable of transmitting data at 100/1000 megabits per second. Ensure that each optical port consists of a pair of fibers; one fiber will transmit (TX) data and one fiber will receive (RX) data. Ensure that the optical ports have an optical power budget of at least 15 dB.

Copper Ports: Provide an edge switch that includes a minimum of four copper ports. Provide Type RJ-45 copper ports and that auto-negotiate speed (i.e., 10/100/1000 Base) and duplex (i.e., full or half). Ensure that all 10/100/1000 Base TX ports meet the specifications detailed in this section and are compliant with the IEEE 802.3 standard pinouts. Ensure that all Category 5E unshielded twisted pair/shielded twisted pair network cables are compliant with the EIA/TIA-568-B standard.

Port Security: Ensure that the edge switch supports/complies with the following (remotely) minimum requirements:

- Ability to configure static MAC addresses access;
- Ability to disable automatic address learning per ports; know hereafter as Secure Port. Secure Ports only forward; and
- Trap and alarm upon any unauthorized MAC address and shutdown for programmable duration. Port shutdown requires administrator to manually reset the port before communications are allowed.

F. Management Capabilities:

Ensure that the edge switch supports all Layer 2 management features and certain Layer 3 features related to multicast data transmission and routing. These features shall include, but not be limited to:

TS-102

- An STP healing/convergence rate that meets or exceeds specifications published in the IEEE 802.1 D standards;
- An RSTP healing/convergence rate that meets or exceeds specifications published in the IEEE 802.1w standard;
- An Ethernet edge switch that is a port-based VLAN and supports VLAN tagging that meets or exceeds specifications as published in the IEEE 802.1Q standard, and has a minimum 4-kilobit VLAN address table (254 simultaneous);
- A forwarding/filtering rate that is a minimum of 14,880 packets per second for 10 megabits per second, 148,800 packets per second for 100 megabits per second and 1,488,000 packets per second for 1000 megabits per second;
- A minimum 4-kilobit MAC address table;
- Support of Traffic Class Expediting and Dynamic Multicast Filtering.
- Support of, at a minimum, snooping of Version 2 & 3 of the Internet Group Management Protocol (IGMP);
- Support of remote and local setup and management via telnet or secure Web-based GUI and command line interfaces; and
- Support of the Simple Network Management Protocol (SNMP). Verify that the Ethernet edge switch can be accessed using the resident EIA-232 management port, a telecommunication network, or the Trivial File Transfer Protocol (TFTP).

Network Capabilities: Provide an edge switch that supports/complies with the following minimum requirements:

- Provide full implementation of IGMPv2 snooping (RFC 2236);
- Provide full implementation of SNMPv1, SNMPv2c, and/or SNMPv3;
- Provide support for the following RMON–1 groups, at a minimum:
 - Part 1: Statistics
 - Part 2: History
 - Part 3: Alarm
 - Part 9: Event
- Provide support for the following RMON–2 groups, at a minimum:
 - Part 13: Address Map
 - Part 16: Layer Host
 - Part 17: Layer Matrix
 - Part 18: User History
- Capable of mirroring any port to any other port within the switch;
- Meet the IEEE 802.1Q (VLAN) standard per port for up to four VLANs;
- Meet the IEEE 802.3ad (Port Trunking) standard for a minimum of two groups of four ports;
- Password manageable;
- Telnet/CLI;
- HTTP (Embedded Web Server) with Secure Sockets Layer (SSL); and
- Full implementation of RFC 783 (TFTP) to allow remote firmware upgrades.

Network Security: Provide an edge switch that supports/complies with the following (remotely) minimum network security requirements:

- Multi-level user passwords;
- RADIUS centralized password management (IEEE 802.1X);
- SNMPv3 encrypted authentication and access security;

TS-103

- Port security through controlling access by the users: ensure that the Ethernet edge switch has the capability to generate an alarm and shut down ports when an unauthorized user accesses the network;
- Support of remote monitoring (RMON-1&2) of the Ethernet agent; and
- Support of the TFTP and SNMP. Ensure that the Ethernet edge switch supports port mirroring for troubleshooting purposes when combined with a network analyzer.

G. Electrical Specifications:

Ensure that the edge switch operates and power is supplied with 115 volts of alternating current (VAC). Ensure that the edge switch has a minimum operating input of 110 VAC and a maximum operating input of 130 VAC. Ensure that if the device requires operating voltages other than 120 VAC, supply the required voltage converter. Ensure that the maximum power consumption does not exceed 50 watts. Ensure that the edge switch has diagnostic light emitting diodes (LEDs), including link, TX, RX, speed (for Category 5E ports only), and power LEDs.

H. Environmental Specifications:

Ensure that the edge switch performs all of the required functions during and after being subjected to an ambient operating temperature range of -30 degrees to 165 degrees Fahrenheit as defined in the environmental requirements section of the NEMA TS 2 standard, with a noncondensing humidity of 0 to 95%.

Provide certification that the device has successfully completed environmental testing as defined in the environmental requirements section of the NEMA TS 2 standard. Provide certification that the device meets the vibration and shock resistance requirements of Sections 2.1.9 and 2.1.10, respectively, of the NEMA TS 2 standard. Ensure that the edge switch is protected from rain, dust, corrosive elements, and typical conditions found in a roadside environment.

The edge switch shall meet or exceed the following environmental standards:

- IEEE 1613 (electric utility substations)
- IEC 61850-3 (electric utility substations)
- IEEE 61800-3 (variable speed drive systems)
- IEC 61000-6-2 (generic industrial)
- EMF – FCC Part 15 CISPR (EN5502) Class A

I. Ethernet Patch Cable:

Furnish a factory pre-terminated/pre-connectorized Ethernet patch cable with each edge switch. Furnish Ethernet patch cables meeting the following physical requirements:

- Five (5)-foot length
- Category 5e or better
- Factory-installed RJ-45 connectors on both ends
- Molded anti-snag hoods over connectors
- Gold plated connectors

Furnish Fast Ethernet patch cords meeting the following minimum performance requirements:

- TIA/EIA-568-B-5, Additional Transmission Performance Specifications for 4-pair 100 Ω Enhanced Category 5 Cabling

TS-104

- Frequency Range: 1-100 MHz
- Near-End Crosstalk (NEXT): 30.1 dB
- Power-sum NEXT: 27.1 dB
- Attenuation to Crosstalk Ratio (ACR): 6.1 dB
- Power-sum ACR: 3.1 dB
- Return Loss: 10dB
- Propagation Delay: 548 nsec

17.3. CONSTRUCTION METHODS

A. General:

Ensure that the edge switch is UL listed.

Verify that network/field/data patch cords meet all ANSI/EIA/TIA requirements for Category 5E and Category 6 four-pair unshielded twisted pair cabling with stranded conductors and RJ45 connectors.

Contact the Signal Shop a minimum of 5 days prior to installation for the most current edge switch IP Address, VLAN, subnet mask, default gateway and configuration files.

B. Edge Switch:

Mount the edge switch inside each field cabinet by securely fastening the edge switch to the upper end of the right rear vertical rail of the equipment rack using manufacturer-recommended or Engineer-approved attachment methods, attachment hardware and fasteners.

Ensure that the edge switch is mounted securely in the cabinet and is fully accessible by field technicians without blocking access to other equipment. Verify that fiber-optic jumpers consist of a length of cable that has connectors on both ends, primarily used for interconnecting termination or patching facilities and/or equipment.

17.4. MEASUREMENT AND PAYMENT

Ethernet edge switch will be measured and paid as the actual number of Ethernet edge switches furnished, installed, and accepted.

No separate measurement will be made for Ethernet patch cable, power cord, mounting hardware, nuts, bolts, brackets, or edge switch programming as these will be considered incidental to furnishing and installing the edge switch.

Payment will be made under:

Ethernet Edge Switch.....Each

18. COMMUNICATIONS SYSTEM SUPPORT EQUIPMENT

18.1. DESCRIPTION

Furnish communications system support equipment with all necessary hardware in accordance with the plans and specifications.

18.2. MATERIALS

A. General:

TS-105

Furnish equipment with test probes/leads, batteries (for battery-operated units), line cords (for AC-operated units), and carrying cases. Provide operating instructions and maintenance manuals with each item.

Before starting any system testing or training, furnish all communications system support equipment.

B. Fiber-Optic Support Equipment

B.1 Fiber-optic Restoration Kit:

Furnish a fully functional fiber-optic restoration kit consisting of the following items (minimum):

- Plier-type strippers
- Non-niks fiber stripper tool with procedures
- Buffer tube stripper tool with procedures
- Fiber-optic Cleaver (average cut less than 0.5 degrees from perpendicular) Diamond Blade
- Screw driver set
- 48 Alcohol wipes
- Tape, 3/4-inch, electrician
- Chemical removal wipes
- Metal ruler
- Tweezers
- Crimping pliers
- Mechanical Splice Manual
- Mechanical Splice Fixture
- 12, Non-adhesive, mechanical splices
- 2 Mechanical Splice Trays, 12 Mechanical Splice Devices, Compatible with the Interconnect Centers being installed in the Traffic Signal Controller Cabinets
- Scissors
- Hard-sided, padded, storage case

B.2 Fiber-optic Power Meter:

Furnish fiber-optic power meters for measuring absolute power and link losses, as well as monitoring power levels and testing threshold levels. Provide the following features:

- Spectral range 750 nm to 1700 nm
- Calibrated wavelengths 850, 1310, and 1550 nm
- Accuracy ± 3 percent (± 0.1 dB) at -20 dBm at 70 degrees F
at calibrated wavelengths

TS-106

- Readout resolution4 digits, 0.01 dBm
- DisplayBacklit LCD
- Fiber-optic connector ST type
- Power-up stabilizationLess than five seconds at ambient temperature
- Tone threshold settingsUser selectable from 1 to 35 dB, plus OFF
- Analog output port
 - Voltage0 to + 1 V FSD of linear power range
 - Output impedance5 kilohms, nominal
- Temperature
 - Operating32 to 122 degrees F
 - Storage0 to 150 degrees F
- Relative humidity5 to 95 percent, non-condensing
- Battery powerAlkaline: 28 hours; NiCad: 8 hours (recharger and NiCad batteries provided)
- Carrying case

B.3 Optical Light Generator:

Furnish optical light generators for measuring absolute power and link losses, as well as monitoring power levels and testing threshold levels. Provide the following features:

- Calibrated wavelengths 1310 nm, and 1550 nm
- Accuracy3 percent at 70 degrees F at calibrated wavelengths
- Fiber-optic connectorST type
- Power-up stabilizationLess than five seconds at ambient temperature
- Temperature
 - Operating32 to 122 degrees F
 - Storage-10 to 150 degrees F
- Relative humidity5 to 95 percent, non-condensing
- Battery powerAlkaline: 28 hours; NiCad: 8 hours (recharger and NiCad batteries provided)
- Carrying case

B.4 SMFO Transceiver (For Emergency Restoration):

Furnish SMFO transceivers identical to the type installed in the traffic signal controller cabinets to be used for emergency restoration of the system and the fiber-optic communications system.

B.5 Ethernet Edge Switch (For Emergency Restoration):

TS-107

Furnish Ethernet Edge Switch identical to the type installed in the traffic signal controller cabinets to be used for emergency restoration of the system and the fiber-optic communications system.

C. Wireless Radio Support Equipment

C.1 Wireless Radio Modem

Furnish wireless radio modem identical to the type installed in the traffic signal controller cabinets to be used for emergency restoration of the system and the wireless communications system.

C.2 Lightning Arrestor

Furnish wireless radio lightning arrestors identical to the type installed in the traffic signal controller cabinets to be used for emergency restoration of the transient voltage suppression equipment.

18.3. MEASUREMENT AND PAYMENT

Actual number of fiber-optic restoration kits furnished and accepted.

Actual number of fiber-optic power meters furnished and accepted.

Actual number of optical light generators furnished and accepted.

Actual number of fiber-optic transceivers furnished and accepted.

Actual number of Ethernet Edge Switch furnished and accepted.

Actual number of wireless radio modems furnished and accepted.

Actual number of wireless radio lightning arrestors furnished and accepted.

Payment will be made under:

Furnish Fiber-optic Restoration Kit.....	Each
Furnish Fiber-optic Power Meter.....	Each
Furnish Fiber-optic Light Generator.....	Each
Furnish Fiber-optic Transceiver.....	Each
Furnished Ethernet Edge Switch.....	Each
Furnish Wireless Radio Modem.....	Each
Furnish Wireless Lightning Arrestor.....	Each

19. FIBER-OPTIC TRAINING

19.1. DESCRIPTION

Provide training for the installation, operation and maintenance of the fiber-optic communications cable, fiber-optic transceivers, interconnect centers, splice trays and other related fiber-optic equipment in accordance with the plans and specifications.

19.2. MATERIALS

Provide training to properly install, operate, maintain, diagnose and repair each piece of equipment associated with the fiber-optic system. Provide approved manufacturer's representatives or other qualified personnel to conduct training courses. Provide training for a minimum of fifteen Department personnel.

TS-108

Before beginning the training course, submit detailed course curricula, draft manuals, and handouts, and resumes of the instructors for review and approval. The Engineer may request modification of the material and request courses desired by the Department.

Conduct all training courses at a location provided by the Department within the Division and at a time mutually agreed upon, but not later than the start of fiber-optic cable testing. Provide training material, manuals, and other handouts to serve not only as subject guidance, but also as quick reference for use by the students. Deliver course material in reproducible form immediately following the course.

Record each training course onto DVD(s) and deliver to the Engineer.

Provide instruction on basic fiber-optic theories and principals as well as the installation, operation, maintenance, identification, detection, and correction of malfunctions in fiber-optic communications cable and related hardware. Include field level troubleshooting as an integral part of the training.

Provide training for the fiber-optic system for the following categories and for the minimum number of hours shown:

COURSE OUTLINES (L = Lecture; D = Demonstration; H = Hands-on by Student)

TRANSCEIVER

DAY 1 (4 Hours)

Safety - (L)

Introduction to transceivers - (L)

Review of Maintenance Manual - (L)

Review of Operations Manual - (L)

Question and answer session

FIBER-OPTIC CABLE SYSTEM

DAY 1 (8 Hours)

Safety - (L)

Introduction to fiber optics, theory, and principals - (L)

Fiber and cable types -(L, H)

National Electrical Code considerations - (L, H)

plenum and riser type cable

out door cable, etc.

Introduction to terminating hardware, end equipment, and applications - (L, D, H)

connectors (ST, SC, etc.)

splice enclosure, splice trays, and connector panels

cable placement techniques

Question and answer session

TS-109

DAY 2 (8 Hours)

Cable handling and preparation (sheath removal, grip installation, etc.) - (L, D, H)

Splicing and terminating methods - (L, D, H)

 mechanical splicing using various techniques

 fusion splicing

 field termination of connectors types

Introduction to cable plant testing procedures - (L, D, H)

 proper usage of optical light generator and power meter

 optical time domain reflectometer usage

Class project (build working system using cables/connectors made by attendees) - (L, D, H)

Question and answer session

DAY 3 (4 Hours)

Class project -- Testing and troubleshooting -- (L, D, H)

Cable system maintenance and restoration -- (L)

Question and answer session

19.3. MEASUREMENT AND PAYMENT

Lump sum for fiber-optic training with training packages completed and accepted.

Payment will be made under:

Fiber-optic Training.....Lump Sum

20. MODIFY SPREAD SPECTRUM WIRELESS RADIO

20.1. DESCRIPTION

Make modifications to existing Spread Spectrum Radio installations.

20.2. MATERIALS

Material, equipment, and hardware furnished under this section shall be pre-approved on the Departments' QPL.

Reference Article 1098-18 "Spread Spectrum Wireless Radio" of the Standard Specifications for Roads and Structures.

20.3. CONSTRUCTION METHODS

This item of work involves making modifications to existing wireless installations which include relocating an existing radio from an existing cabinet to a new cabinet, and/or relocating existing components of the radio system from an existing pole to new poles (wood poles, metal strain poles, metal poles with mast arms, etc.). This item of work includes, but may not be limited to, the following:

 Relocating existing radio from an existing cabinet to a new cabinet

 Relocating or installing new Coaxial Cable

TS-110

- Furnishing and installing new N-Type Connectors
- Furnishing new Coaxial Cable and Shield Grounding Kits
- Relocating Antenna Mounting Hardware
- Relocating Antennas

This item of work may also involve converting an existing standalone radio site to a repeater site. This item of work includes, but may not be limited to, the following:

- Furnishing and installing new antenna(s)
- Furnishing and installing new antenna mounting hardware kits
- Furnishing and installing new 6 foot coaxial cable jumpers with N-Type Connectors
- Furnishing and installing new coaxial cable – power divider (Splitters)

20.7. MEASUREMENT AND PAYMENT

Modify Radio Installation will be measured as the actual number of modified radio installations that are modified and accepted.

This item includes relocating the radio, and furnishing and/or relocating and installing coaxial cable, N-Type Connectors, coaxial cable shield grounding kits, antenna mounting hardware, antennas, coaxial cable and power dividers. This item of work may also involve furnishing and installing new decals and furnishing or relocating signs. This item of work may also involve re-programming the radio.

Payment for new risers will be covered separately.

Payment will be made under:

Modify Radio InstallationEach

21. SOLAR POWER, 900 MHZ SPREAD SPECTRUM RADIO

21.1. DESCRIPTION

Furnish an operational Solar Power, 900MHz Spread Spectrum Radio System installed in a NEMA Type 3R enclosure for pole mounting.

Furnish material and workmanship conforming to the *National Electrical Code* (NEC), the *National Electrical Safety Code* (NESC), Underwriter’s Laboratories (UL) or a third-party listing agency accredited by the North Carolina Department of Insurance, and all local safety codes in effect on the date of advertisement. Comply with all regulations and codes imposed by the owner of affected utility poles.

TS-111

21.2. MATERIALS

A. 900MHz Wireless Radio System:

Furnish a 900 MHz Radio that complies with Section 1098-18 (B) of the 2018 Standard Specifications for Roads and Structures.

Furnish 8.5 dB or 13 dB gain Directional Antenna (Yagi Antenna) that complies with Section 1098-18 (F) of the 2018 Standard Specifications for Roads and Structures.

Furnish 3dB or 6 dB Omni Directional Antenna that complies with Section 1098-18 (G) of the 2018 Standard Specifications for Roads and Structures.

Furnish Antenna Mounting Hardware Kits that comply with Section 1098-18 (H) of the 2018 Standard Specifications for Roads and Structures.

Furnish 400 Series Coaxial Cable that complies with Section 1098-18 (I) of the 2018 Standard Specifications for Roads and Structures.

Furnish Standard N-Type Connectors that comply with Section 1098-18 (J) of the 2018 Standard Specifications for Roads and Structures.

Furnish Coaxial Cable Shield Grounding and Weatherproofing Kits that comply with Section 1098-18 (K) of the 2018 Standard Specifications for Roads and Structures.

Furnish Lightning Arrestors that comply with Section 1098-18 (L) of the 2018 Standard Specifications for Roads and Structures.

Furnish Coaxial Cable – Power Divider (Splitter) that complies with Section 1098-18 (M) of the 2018 Standard Specifications for Roads and Structures.

Furnish 1 inch and 2 inch Rigid Metallic Conduit that complies with Section 1091-3 (B) of the 2018 Standard Specifications for Roads and Structures.

Furnish 1 inch clamp-on aluminum weatherheads and 1 1/2 inch heat shrink tubing that complies with Section 1098-4 of the 2018 Standard Specifications for Roads and Structures.

B. Solar Powered Assembly:

B.1 General:

Furnish a Solar Power Assembly consisting of the following:

- Solar Array
- Solar Charge Controller
- Load Controller
- Battery(ies)
- NEMA 3R Equipment Cabinet

Ensure that DC disconnects are supplied between the Solar Array and the Solar Charge Controller, and between the Solar Charge Controller and the Battery(ies), and between the Battery(ies) and any other equipment.

TS-112

B.2 Solar Power System Design Requirements:

Provide to the Engineer for Approval, a submittal package with Engineering Calculations consisting of, as a minimum, schematic drawing, technical data sheets, and supporting documentation. Ensure the documentation demonstrates, in theory, that the battery(ies) will provide for continuous operation for a minimum of ten (10) consecutive days with no additional charging under the following conditions:

- a) Fully powering the Wireless Repeater Radio operating 24 hours a day with 50% of that time being in a standby (sleep) mode; and 50% of the time being in operational mode.

Provide drawings showing dimension, location of required equipment, cabinet electrical diagrams, part numbers and descriptions of required equipment and accessories to the Engineer.

B.3 Solar Array:

Furnish solar modules made in North America and have a minimum 20 year factory warranty. The solar array should have a minimum peak output of 80 Watts. Solar modules must be UL listed, FM Class I, Div II, Group C&D approved. For the solar array, power wiring should be 10-2, stranded copper, double insulated, sunlight resistant, 600V 90C rated cable. Ensure the solar array mount is manufactured from an aluminum alloy or stainless steel and is capable of withstanding 140 mph winds.

B.4 Solar Charger Controller:

Furnish a Pulse Width Modulation (PWM) solar charge controller that is UL listed, with a minimum 20A solid state, low voltage disconnect. The solar charge controller must be sealed with internal temperature compensation, lightning protection, reverse polarity protection, and LED indicators. Furnish controllers with the capability of 3 functions: battery charging, load control, and diversion regulation. Controllers must be furnished with fully adjustable DIP switches and RS-232 communications port to adjust the unit's operational modes. Ensure the solar charge controller is listed as a FM Class I, Div. II, Groups ABCD device and has the CE mark.

B.5 Load Controller:

Furnish a load controller that is identical to the solar charger controller provided as part of the solar power assembly. Configure the load controller to regulate the voltage of the assembly according to the manufacturer's recommendation.

B.6 Batteries:

Provide a 12V gel electrolyte, non-spillable, maintenance free battery. The battery(ies) should be able to provide power for 10 days without being charged by the Solar Array. Furnish battery(ies) with a minimum operating temperature of -76° F to 140°F.

TS-113

B.7 NEMA 3R Equipment Cabinet:

Provide a NEMA 3R type Equipment Cabinet enclosure that is of a pole mount design, with compartments to house the battery(ies) and electronic components separately. Ensure that the equipment installed inside the cabinet does not occupy more than 60% of the total cabinet volume.

Ensure that the battery compartment and the electronic equipment compartments are ventilated with a screen and louvered vents. Equip vents with standard-size, replaceable furnace type vent filters. Size the filter tray to adequately house and secure the filter in place. Ensure there are no obstructions on the interior face of the door to interfere with easy removal and replacement of filter.

Provide an enclosure that is fabricated with unpainted, natural, aluminum that complies with Section 7 of NEMA TS-2-1998. Ensure the equipment cabinet enclosure shell is fitted with one (1) Corbin Number 2 Key, lifting handles, exhaust ports. Provide all necessary hardware to mount the enclosure securely to the pole. Provide hardware that is stainless steel or a Department approved non-corrosive alternate including the hinges and lifting handle.

Provide roof with slope (from front to back) at a minimum ratio of 1" drop per 2 feet. Ensure roof is flush with front of the door. Ensure each exterior cabinet plane surface is constructed of a single sheet of seamless aluminum.

Provide a handle and three point latching mechanism designed to be disassembled using hand tools. Provide a shaft connecting the latching plate to the door handle by passing through the door within a bushing, bearing, or equivalent device. Provide a latching plate at least 1/8 inch thick and that mates securely with the lock bolt. Provide a lock bolt with a flat end (no bevel) and that has at least 1/4 inch of length in contact with the latching plate.

Ensure that the handle and lock are positioned so that the lock does not lie in the path of the rotating handle as the door is unlatched and that the handle points down in the latched position.

Provide a main door opening that encompasses the full frontal area of the cabinet shell. Ensure that the cabinet shell is sturdy and does not exhibit noticeable flexing, bending or distortion under normal conditions, except that a minor amount of flexing is permitted in the main door when the cabinet is open. In such case, the flexing must not result in permanent deformation of the door.

A police panel door is not required for these cabinets.

Equipment in the equipment cabinet enclosure will be shelf mounted. Provide one equipment shelf in the cabinet that extends the practical width of the cabinet. Ensure that the shelf can be moved up and down within the cabinet. Do not locate permanently mounted equipment in such a way that will restrict access to terminals. Ensure all components are arranged for easy access during servicing. When modular in construction, provide guides and positive connection devices to ensure proper pin alignment and connection.

Arrange equipment and terminals within the cabinet so that they will not interfere with the entrance, tracing and connection of conductors or other cables. Ensure all incoming and outgoing conductors are connected to terminal blocks. Ensure all field terminals are readily accessible without having to remove equipment to gain access. Ensure terminals are not located on the underside of shelf or at any other place where they are not readily visible or where they may present a hazard to personnel who might inadvertently touch them.

TS-114

Provide terminal blocks that are made of electrical grade thermoplastic or thermosetting plastic. Ensure each terminal block is of closed back design and has recessed-screw terminals with molded barriers between terminals. Ensure each terminal consists of two terminal screws with removable shorting bar between them. Ensure all terminal blocks and terminals are labeled with their intended functions. Provide labels that are visible and easy to read when the terminal blocks are wired.

21.3. CONSTRUCTION METHODS

A. Antenna Mounting:

The Engineer will approve final locations of any solar powered radio systems. Install the antenna, antenna mounting hardware, coaxial cable, power divider, antenna splitter cable and additional antenna at locations where it is determined that a dual antenna configuration is necessary to accommodate communications in multiple directions.

Install antenna in accordance with the antenna manufacturer's recommendations. Secure the antenna mounting hardware to the pole and route the coaxial cable such that no strain is placed on the N-Type Male coaxial connectors.

Install the coaxial cable shield grounding system by removing the outer jacket of the coaxial cable without damaging the cable shield. Install the shield grounding system following the cable manufacturer's recommendations. Install and weatherproof the connection using the appropriate weatherproofing materials and following the manufacturer's recommendations. On wood poles, secure the #6 AWG grounding lead cable to the pole ground using split bolt or compression type fitting or an Engineer approved method. On metal poles, secure the #6 AWG grounding lead cable to the pole using an Engineer approved method.

Install the coaxial cable in a 1 1/2 inch riser with heat shrink tubing for connecting into the equipment cabinet. Do not exceed the 1-inch bend radius of the coaxial cable as it traverses from the cabinet to the antenna assembly. Connect the lightning arrestor to the coaxial cable in the equipment cabinet. Properly ground and secure the arrestor in the cabinet. Permanently label all cables entering the cabinet.

Place a copy of all manufacturer equipment specifications and instruction and maintenance manuals in the equipment cabinet.

B. Solar Power Assembly:

Do not obstruct the sight distance of vehicles when locating and installing the equipment cabinet. Mount equipment cabinet so that the height to the middle of the cabinet is 4 feet above grade. Secure the cabinet to the pole using 3/4" stainless steel straps or a method approved by the Engineer.

Ensure that the equipment cabinet along with solar array(s) and its mounting hardware are capable of surviving sustains winds of 140 MPH. Ensure the solar array(s) does not obstruct the view of traffic and that the array(s) are arranged for optimal sunlight exposure for charging of the battery(ies). Mount the array(s) at a minimum height of 25 feet above ground level.

Run field wiring from the solar power array(s) to the equipment cabinet through 1 inch riser with weatherhead and make connections inside the equipment cabinets as required. Install separate DC

TS-115

disconnects between the solar array and the solar charger controller and between the solar charger controller and the battery(ies), and between the battery(ies) and any other equipment. Ensure the DC disconnect allows personnel working on the system to safely isolate critical items from each other while performing maintenance and trouble shooting. Ensure that all wiring including grounding of the solar photovoltaic system meets the requirements of Article 690 of the National Electric Code (NEC) and these project special provisions.

To protect against high voltage power surges, furnish and install one grounding electrode at the equipment cabinet.

Terminate all wires using spade connectors under binding screws on terminal blocks. Label all terminal blocks and terminals for easy identification. Label all wires and harnesses for easy identification. Neatly secure all wiring and harness inside the cabinet in a method approved by the Engineer.

Provide and leave all data interface cables, installation manuals, and specifications and materials used to program any equipment in the Equipment Cabinet. Program all equipment for operation.

21.4. MEASUREMENT AND PAYMENT

Actual number of Solar Power, 900MHz Spread Spectrum Radio Systems furnished, installed and accepted.

This item includes the appropriate sized Solar Power Assembly (Solar Array, Solar Charger Controller, Battery, NEMA 3R equipment cabinet), 1 inch riser with weatherhead, 1 1/2 inch riser with heat shrink tubing, antenna(s), radio, data interface cable/serial cable, coaxial cable, lightning arrestor, radio frequency signal jumper, coaxial cable power divider (Splitter), coaxial cable connectors, coaxial cable shield grounding system with weatherproofing, labeling and any integration, installation materials and configuration software necessary to complete this work, including the Solar Power System Design Calculations and warranties, will be incidental.

Payment will be made under:

Solar Power, 900MHz Spread Spectrum Radio Each

INTELLIGENT TRANSPORTATION SYSTEMS CCTV PROJECT SPECIAL PROVISIONS

Contents

1. GENERAL REQUIREMENTS	2
1.1 DESCRIPTION	2
A. <i>General</i>	2
B. <i>Scope</i>	2
C. <i>Qualified Products</i>	2
D. <i>Warranties</i>	2
2. SOLAR POWER ASSEMBLY	3
2.1 DESCRIPTION	3
2.2 MATERIAL	3
A. <i>Solar Array</i>	3
B. <i>Solar Charger Controller</i>	3
C. <i>Batteries</i>	4
D. <i>Solar Power Assembly Cabinet</i>	4
2.3 CONSTRUCTION METHODS	4
2.4 MEASUREMENT AND PAYMENT	4
3. CCTV CAMERA EQUIPMENT	5
3.1 DESCRIPTION	5
3.2 MATERIAL	5
A. <i>General</i>	5
B. <i>Camera and Lens</i>	5
C. <i>Video Encoding</i>	6
D. <i>Camera Housing</i>	7
E. <i>Pan and Tilt Unit</i>	7
F. <i>Control Receiver/Driver</i>	7
G. <i>CCTV Camera Attachment to Pole</i>	7
H. <i>Surge Suppression</i>	8
3.3 CONSTRUCTION METHODS	8
A. <i>General</i>	8
B. <i>Electrical and Mechanical Requirements</i>	8
3.4 MEASUREMENT AND PAYMENT	8
4. CCTV FIELD EQUIPMENT CABINET	9
4.1 DESCRIPTION	9
4.2 MATERIAL	9
A. <i>Shelf Drawer</i>	9
B. <i>Cabinet Light</i>	9
C. <i>Surge Protection for System Equipment</i>	10
4.3 CONSTRUCTION METHODS	12
4.4 MEASUREMENT AND PAYMENT	12

GENERAL REQUIREMENTS

1.1 DESCRIPTION

A. General

Conform to these Project Special Provisions, Project Plans, and the *2018 Standard Specifications for Roads and Structures* (also referred to hereinafter as the “Standard Specifications”). The current edition of these specifications and publications in effect on the date of advertisement will apply.

In the event of a conflict between these Project Special Provisions and the Standard Specifications, these Project Special Provisions govern.

B. Scope

The scope of this project includes the installation and integration of 5 new pedestal mount Dynamic Message Sign systems (DMSs) and 7 new CCTV cameras at the following locations:

1. CCTV – electrical power, install new CCTV camera assembly and equipment cabinet on new wood pole with a new electrical service.
2. CCTV- Solar powered, install a new CCTV camera assembly and equipment cabinet on a new wood pole. Install solar power assembly equipment.

Integrate the new CCTVs at the Division X Traffic Services office in (List City and Address). Conduct device and system tests as described in these Project Special Provisions.

C. Qualified Products

Furnish new equipment, materials, and hardware unless otherwise required. Inscribe manufacturer’s name, model number, serial number, and any additional information needed for proper identification on each piece of equipment housed in a case or housing.

Furnish factory assembled cables without adapters, unless otherwise approved by the Engineer, for all cables required to interconnect any field or central equipment.

Certain equipment listed in these Project Special Provisions must be pre-approved on the Department’s ITS & Signals 2018 Qualified Products List (QPL) by the date of installation. Equipment, material, and hardware not pre-approved when required will not be allowed for use on the project.

The QPL is available on the Department’s website. The QPL website is:

<http://www.ncdot.org/doh/preconstruct/traffic/ITSS/SMS/qpl/>

D. Warranties

Provide manufacturer’s warranties on Contractor-furnished equipment for material and workmanship that are customarily issued by the equipment manufacturer and that are at least two years in length from successful completion of the 30-day observation period. Include unconditional coverage for all parts and labor necessary or incidental to repair of defective equipment or workmanship and malfunctions that arise during warranty period.

Ensure all contractor-furnished equipment; including pieces and components of equipment, hardware, firmware, software, middleware, internal components, and subroutines which perform any date or time data recognition function, calculation, or sequencing will support a four digit year format for a period of at least 50 years.

Upon successful completion of the 30-day observation period, transfer manufacturer's warranties with proper validation by the manufacturer to the Department or its designated maintaining agency.

2. SOLAR POWER ASSEMBLY

2.1 DESCRIPTION

Install new solar power assembly equipment with equipment cabinets and all necessary hardware in accordance with these Project Special Provisions and the Plans. Comply with the provisions of Section 1700 of the Standard Specifications.

2.2 MATERIAL

Furnish and install a solar power assembly at the locations shown in the Plans consisting of the following:

- Solar Array
- Solar Charge Controller
- Batteries
- Assembly Cabinet
- Concrete Cabinet Pad

A. Solar Array

Furnish solar modules made in North America and have a minimum 20 year factory warranty. The solar array should have a minimum peak output of 100W. Solar modules must be UL listed, FM Class I, Div II, Group C & D approved. For the solar array, power wiring should be 10-2, stranded copper, double insulated, sunlight resistant, 600V 90C rated cable. The array mount will attach to the side of the CCTV pole with stainless steel fasteners. The array mount must be aluminum alloy or stainless steel. The array must be capable of withstanding 125 mph winds.

B. Solar Charger Controller

Furnish solar charge controllers that are UL listed, a minimum 45A with solid state, low voltage disconnects. Ensure that the solar charge regulator is sealed with internal temperature compensation, lightning protection, reverse polarity protection, and LED indicators. Provide controllers with the capability of 3 functions: battery charging, load control, and diversion regulation. Controllers must be furnished with fully adjustable DIP switches and RS-232 communications port to adjust the unit's operational modes. Ensure the solar charge regulator is FMS Class I, Groups ABCD and have the CE mark.

C. Batteries

Provide 12V gel electrolyte, non-spillable, maintenance free batteries. Furnish batteries capable of providing power for 10 days without being charged by the Solar Array and Solar Charge Controller. Furnish batteries with a minimum operating temperature of -76° F to 140°F.

D. Solar Power Assembly Cabinet

Furnish a solar power assembly cabinet constructed of 0.125” aluminum with stainless steel hardware. There must be separate compartments for the batteries and the electronics. The enclosures must be NEMA 3R rated and large enough to contain all solar equipment and incidental components, including 20% spare space.

2.3 CONSTRUCTION METHODS

Furnish and install new solar power assemblies. Provide wiring, disconnects, and all other required equipment as required by Article 690 of the NEC.

Install solar panel collectors at a height that will prohibit theft and/or vandalism. At a minimum, mount the solar panel collectors 20 feet from ground level. Installation of multiple collector panels shall be approved by the Engineer prior to installation.

Ensure that the maximum resistance between the grounding electrode and all points in the grounding system does not exceed 5 ohms.

In addition to the requirements of the NEC, test grounding electrode resistance at the connection point to the electrical service ground bus for a maximum of 20 ohms. Furnish and install ground rods to the grounding electrode system as necessary to meet the test requirements.

2.4 MEASUREMENT AND PAYMENT

Solar Power Assembly will be measured and paid as the actual number of solar power assemblies furnished, installed and accepted.

No measurement will be made for solar arrays, solar power assembly equipment cabinet, installing breakers, inverters, temperature sensors, concrete cabinet pad, mounting system, grounding system, conduits, risers, wiring, and hardware as these will be considered incidental to furnishing and installing the solar power assembly.

Payment will be made under:

Pay Item	Pay Unit
Solar Power Assembly	Each

3. CCTV CAMERA EQUIPMENT

3.1 DESCRIPTION

Furnish and install hybrid CCTV camera equipment with analog and digital video outputs described in these Project Special Provisions. Furnish equipment that is compatible, interoperable, and completely interchangeable with existing Pelco Spectra IV high-performance dome equipment currently in use by NCDOT in this Region. Ensure that the equipment is fully compatible with all features of the existing *VideoPro* video management software currently in use by NCDOT in this Region.

3.2 MATERIAL

A. General

Furnish and install new CCTV camera assemblies at the locations shown on the Plans. Each assembly consists of the following:

- One dome CCTV color digital signal processing camera unit with zoom lens, filter, control circuit, and accessories in a single enclosed unit
- Built-in video encoder capable of H.264 compression for video transmission using IP protocols
- Motorized pan, tilt, and zoom
- Pole-mount camera attachment assembly
- All necessary cable, connectors and incidental hardware to make a complete and operable system
- A lightning arrestor installed in-line between the CCTV camera and the equipment cabinet components.
- A NEMA-rated enclosure constructed of aluminum with a clear acrylic dome or approved equal Camera Unit housing.

B. Camera and Lens

1. Cameras

Furnish new charged-coupled device (CCD) color cameras. The camera must meet the following minimum requirements:

- Video signal format: NTSC composite color video output, 1 volt peak to peak
- Automatic Gain Control (AGC): 0-20 dB, peak-average adjustable
- Automatic focus: Automatic with manual override
- White balance: Automatic through the lens with manual override
- Overexposure protection: The camera must have built-in circuitry or a protection device to prevent any damage to the camera when pointed at strong light sources, including the sun
- Sensitivity: 1.5 lux at 90% scene reflectance
- Signal to noise ratio: Greater than 50-dB

- Video output Connection: 1-volt peak to peak, 75 ohms terminated, BNC connector
- Power: 24 VAC or less

2. Zoom Lens

Furnish each camera with a motorized zoom lens that is high performance integrated dome system or approved equivalent with automatic iris control with manual override and neutral density spot filter. Furnish lenses that meet the following optical specifications:

- Focal length: 3.4 mm to 119mm, 35X optical zoom, and 12X electronic zoom
- Preset positioning: 64 Presets

The lens must be capable of both automatic and remote manual control iris and focus override operation. The lens must be equipped for remote control of zoom and focus, including automatic movement to any of the preset zoom and focus positions. Mechanical or electrical means must be provided to protect the motors from overrunning in extreme positions. The operating voltages of the lens must be compatible with the outputs of the camera control.

C. Video Encoding

1. Video Specification

- Video Resolution: 704x480, NTSC
- Frame Rate: scalable from 1 fps up to 30 fps
- Two simultaneous video streams (Dual H.264 and MJPEG):
 - Video 1: H.264 (Main Profile, at minimum)
 - Video 2: H.264 or MJPEG

2. Networking Standards:

- Port: RJ-45
- Network Connection: 10/100 Mbps auto-negotiate
- Built-in Web Server
- Unicast & multicast support
- Supported Protocols: DNS, IGMPv2, NTP, RTSP, RTP, TCP, UDP, DHCP, HTTP, IPv4

The video camera shall allow for the simultaneous encoding and transmission of the two digital video streams, one in H.264 format (high-resolution) and one in H.264 or MJPEG format (low-resolution).

Initially use UDP/IP for video transport and TCP/IP for camera control transport unless otherwise approved by the Engineer.

The 10/100BaseTX port shall support half-duplex or full-duplex and provide auto negotiation, and shall be initially configured for full-duplex.

The camera unit shall be remotely manageable using standard network applications via web browser interface administration. Telnet or SNMP monitors shall be provided.

D. Camera Housing

Furnish new dome style enclosure for the CCTV assemblies. Equip each housing with mounting assembly for attachment to the CCTV camera pole. The enclosures must be equipped with a sunshield and be fabricated from corrosion resistant aluminum and finished in a neutral color of weather resistant enamel. The enclosure must meet or exceed NEMA 4X ratings. The viewing area of the enclosure must be tempered glass.

E. Pan and Tilt Unit

Equip each new dome style assembly with a pan and tilt unit. The pan and tilt unit must be integral to the high performance integrated dome system. The pan and tilt unit must be rated for outdoor operation, provide dynamic braking for instantaneous stopping, prevent drift, and have minimum backlash. The pan and tilt units must meet or exceed the following specifications:

- Pan: continuous 360 Degrees
- Tilt: up/down 180 degrees minimum
- Input voltage: 24 VAC 50/60Hz
- Motors: Two-phase induction type, continuous duty, instantaneous reversing
- Preset Positioning: 256 PTZ presets per camera

F. Control Receiver/Driver

Provide each new camera unit with a control receiver/driver that is integral to the CCTV dome assembly. The control receiver/driver will receive serial asynchronous data initiated from a camera control unit, decode the command data, perform error checking, and drive the pan/tilt unit, camera controls, and motorized lens. As a minimum, the control receiver/drivers must provide the following functions:

- Zoom in/out
- Automatic focus with manual override
- Tilt up/down
- Automatic iris with manual override
- Pan right/left
- Minimum 256 preset positions for pan, tilt, and zoom

In addition, each control receiver/driver must accept status information from the pan/tilt unit and motorized lens for preset positioning of those components. The control receiver/driver will relay pan, tilt, zoom, and focus positions from the field to the remote camera control unit. The control receiver/driver must accept “goto” preset commands from the camera control unit, decode the command data, perform error checking, and drive the pan/tilt and motorized zoom lens to the correct preset position. The preset commands from the camera control unit will consist of unique values for the desired pan, tilt, zoom, and focus positions.

G. CCTV Camera Attachment to Pole

At locations shown in the Plans where new CCTV cameras are to be installed on new CCTV poles, furnish an attachment assembly for the CCTV camera unit. Use stainless steel banding approved by the Engineer.

Furnish CCTV attachments that allow for the removal and replacement of the CCTV enclosure as well as providing a weatherproof, weather tight, seal that does not allow moisture to enter the enclosure.

Furnish a CCTV Camera Attachment Assembly that is able to withstand wind loading at the maximum wind speed and gust factor called for in these Special Provisions and can support a minimum camera unit dead load of 45 pounds.

H. Surge Suppression

Protect all equipment at the top of the pole grounded metal oxide varistors connecting each power conductor to ground.

Protect the electrical, coaxial, and Ethernet cables from the CCTV unit entering the equipment cabinet with surge protection.

3.3 CONSTRUCTION METHODS

A. General

Mount CCTV camera units at a height sufficient to adequately see traffic in all directions and as approved by the Engineer. The maximum attachment height is 35 feet above ground level.

Mount the CCTV camera units such that a minimum 5 feet of clearance is maintained between the camera and the top of the pole.

Obtain approval of the camera locations and orientation from the Engineer prior to installing the CCTV camera assemblies.

Mount CCTV cameras on the side of poles nearest intended field of view. Avoid occluding the view with the pole.

B. Electrical and Mechanical Requirements

Ground all equipment as called for in the Standard Specifications, these Special Provisions, and the Plans.

Install surge protectors on all ungrounded conductors entering the CCTV enclosure. House the protectors in a small, ventilated weatherproof cabinet attached near the CCTV attachment point in a manner approved by the Engineer.

3.4 MEASUREMENT AND PAYMENT

Hybrid CCTV camera assembly will be measured and paid as the actual number of hybrid CCTV assemblies furnished, installed, integrated, and accepted. No separate measurement will be made for electrical cabling, coaxial cabling, Ethernet cabling, connectors, CCTV camera attachment assemblies, conduit, condulets, grounding equipment, surge protectors, CCTV control software, or any other equipment or labor required to install the CCTV assembly.

No separate payment will be made for coaxial cable. Coaxial cable, furnished and installed in the quantities required, will be incidental to the "CCTV Assembly" pay item.

Payment will be made under:

Pay Item

Hybrid CCTV Camera AssemblyEach

4. CCTV FIELD EQUIPMENT CABINET

4.1 DESCRIPTION

Furnish 336 pole mounted cabinets to house CCTV control and transmission equipment. The cabinets must consist of a cabinet housing, 19-inch EIA mounting cage, and power distribution assembly (PDA #3 as described in the CALTRANS TSCES).

The cabinet housing must conform to sections 6.2.2 (Housing Construction), 6.2.3 (Door Latches and Locks), 6.2.4 (Housing Ventilation), and 6.2.5 (Hinges and Door Catches) of the CALTRANS TSCES. Do not equip the cabinet housings with a police panel.

The cabinet cage must conform to section 6.3 of the CALTRANS TSCES.

Terminal blocks on the PDA #3 Assembly have internal wiring for the Model 200 switch pack sockets. Do not use terminal blocks on PDA #3 as power terminals for cabinet devices. Do not furnish cabinet with "Input Panels" described in section 6.4.7.1 of the TSCES. Do furnish cabinet with "Service Panels" as described in section 6.4.7.1 of the TSCES and as depicted on drawing TSCES-9 in the TSCES. Use service panel #2.

Furnish terminal blocks for power for cabinet CCTV and communications devices as needed to accommodate the number of devices in the cabinet.

Do not furnish cabinets with C1, C5, or C6 harness, input file, output file, monitor units, model 208 unit, model 430 unit, or switch packs.

Furnish all conduits, shelving, mounting adapters, and other equipment as necessary to route cabling, mount equipment, and terminate conduit in equipment cabinet.

4.2 MATERIAL

A. Shelf Drawer

Provide a pull out, hinged-top drawer, having sliding tracks, with lockout and quick disconnect feature in the equipment cabinet. Furnish a pullout drawer that extends a minimum of 14 inches that is capable of being lifted to gain access to the interior of the drawer. Minimum interior dimensions of the drawer are to be 1 inch high, 13 inches deep, and 16 inches wide. Provide drawers capable of supporting a 40-pound device or component when fully extended.

B. Cabinet Light

Each cabinet must include two (2) fluorescent lighting fixtures (one front, one back) mounted horizontally inside the top portion of the cabinet. The fixtures must include a cool white lamp, and must be operated by normal power factor UL-listed ballast. A door-actuated switch must be

installed to turn on the applicable cabinet light when the front door or back door is opened. The lights must be mounted not to interfere with the upper door stay.

C. Surge Protection for System Equipment

Each cabinet must be provided with devices to protect the CCTV and communications equipment from electrical surges and over voltages as described below.

1. Main AC Power Input

Each cabinet must be provided with a hybrid-type, power line surge protection device mounted inside the power distribution assembly. The protector must be installed between the applied line voltage and earth ground. The surge protector must be capable of reducing the effect of lightning transient voltages applied to the AC line. The protector must be mounted inside the Power Distribution Assembly housing facing the rear of the cabinet. The protector must include the following features and functions:

- Maximum AC line voltage: 140 VAC.
- Twenty pulses of peak current, each of which must rise in 8 microseconds and fall in 20 microseconds to ½ the peak: 20000 Amperes.
- The protector must be provided with the following terminals:
 - Main Line (AC Line first stage terminal).
 - Main Neutral (AC Neutral input terminal).
 - Equipment Line Out (AC line second state output terminal, 19 amps).
 - Equipment Neutral Out (Neutral terminal to protected equipment).
 - GND (Earth connection).
- The Main AC line in and the Equipment Line out terminals must be separated by a 200 Microhenry (minimum) inductor rated to handle 10 AMP AC Service.
- The first stage clamp must be between Main Line and Ground terminals.
- The second stage clamp must be between Equipment Line Out and Equipment Neutral.
- The protector for the first and second stage clamp must have an MOV or similar solid state device rated at 20 KA and must be of a completely solid state design (i.e., no gas discharge tubes allowed).
- The Main Neutral and Equipment Neutral Out must be connected together internally and must have an MOV similar solid state device or gas discharge tube rated at 20 KA between Main Neutral and Ground terminals.
- Peak Clamp Voltage: 350 volts at 20 KA. (Voltage measured between Equipment Line Out and Equipment Neutral Out terminals. Current applied between Main Line and Ground Terminals with Ground and Main Neutral terminals externally tied together).
- Voltage must never exceed 350 volts.
- The Protector must be epoxy-encapsulated in a flame-retardant material.
- Continuous service current: 10 Amps at 120 VAC RMS.
- The Equipment Line Out must provide power to cabinet CCTV and communications equipment and to the 24V power supply.

2. Ground Bus

Provide a neutral bus that is not connected to the earth ground or the logic ground anywhere within the cabinet. Ensure that the earth ground bus and the neutral ground bus each have ten compression type terminals, each of which can accommodate wires ranging from number 14 through number 4 AWG.

3. Uninterruptible Power Supply (UPS)

Furnish and install one rack mounted UPS in each new cabinet that meet the following minimum specifications:

Output

Output Power Capacity	480 Watts / 750 VA
Max Configurable Power	480 Watts / 750 VA
Nominal Output Voltage	120V
Output Voltage Distortion	Less than 5% at full load
Output Frequency (sync to mains)	57 - 63 Hz for 60 Hz nominal
Crest Factor	up to 5:1
Waveform Type	Sine wave
Output Connections	(4) NEMA 5-15R

Input

Nominal Input Voltage	120V
Input Frequency	50/60 Hz +/- 3 Hz (auto sensing)
Input Connections	NEMA 5-15P
Cord Length	6 feet
Input voltage range for main operations	82 - 144V
Input voltage adjustable range for mains operation	75 -154 V

Battery Type

Maintenance-free sealed Lead-Acid battery with suspended electrolyte, leak-proof.

Typical recharge time	2 hours
-----------------------	---------

Communications & Management

Interface Port(s)	DB-9 RS-232, USB
Control panel	LED status display with load and battery bar-graphs

Surge Protection and Filtering

Surge energy rating	480 Joules
---------------------	------------

Environmental

Operating Environment	32 - 104 °F
Operating Relative Humidity	0 - 95%

Storage Temperature	5 - 113 °F
Storage Relative Humidity	0 - 95%

Conformance

Regulatory Approvals	FCC Part 15 Class A, UL 1778
----------------------	------------------------------

4.3 CONSTRUCTION METHODS

For each field equipment cabinet installation, use stainless steel banding or other method approved by the Engineer to fasten cabinet to pole. Install field equipment cabinets so that the height to the middle of the enclosure is 4 feet from ground level. No risers shall enter the top or sides of the equipment cabinet.

Install all conduits, condulets, and attachments to equipment cabinets in a manner that preserves the minimum bending radius of cables and creates water proof connections and seals.

Install a UPS in each cabinet and power all CCTV cameras from the UPS.

4.4 MEASUREMENT AND PAYMENT

Field equipment cabinet will be measured and paid as the actual number of CCTV equipment cabinets furnished, installed and accepted.

No payment will be made for the UPS, cabling, connectors, cabinet attachment assemblies, conduit, condulets, risers, grounding equipment, surge protectors, or any other equipment or labor required to install the field equipment cabinet and integrate the cabinets with the CCTV equipment.

Payment will be made under:

Pay Item	Pay Unit
Field Equipment Cabinet.....	Each

PORTLAND CEMENT CONCRETE PRODUCTION AND DELIVERY:

(9-15-20)

1000, 1014, 1024

Revise the 2018 Standard Specifications as follows:

Page 10-6, Table 1000-1, REQUIREMENTS FOR CONCRETE, replace with the following:

TABLE 1000-1 REQUIREMENTS FOR CONCRETE											
Class of Concrete	Min. Compressive Strength at 28 days	Maximum Water-Cement Ratio				Consistency Maximum Slump		Cement Content			
		Air-Entrained Concrete		Non-Air- Entrained Concrete		Vibrated	Non- Vibrated	Vibrated		Non-Vibrated	
		Rounded Aggregate	Angular Aggregate	Rounded Aggregate	Angular Aggregate			Min.	Max.	Min.	Max.
		Units	psi					inch	inch	lb/cy	lb/cy
AA	4500	0.381	0.426	---	---	3.5 ^A	---	639	715	---	---
AA Slip Form	4500	0.381	0.426	---	---	1.5	---	639	715	---	---
Drilled Pier	4500	---	---	0.450	0.450	---	5 – 7 dry 7 - 9 wet	---	---	640	800
A	3000	0.488	0.532	0.550	0.594	3.5 ^A	4.0	564	---	602	---
B	2500	0.488	0.567	0.559	0.630	1.5 machine placed 2.5 ^A hand placed	4.0	508	---	545	---
Sand Light- weight	4500	---	0.420	---	---	4.0 ^A	---	715	---	---	---
Latex Modified	3000 (at 7 days)	0.400	0.400	---	---	6.0	---	658	---	---	---
Flowable Fill excavatable	150 max. (at 56 days)	as needed	as needed	as needed	as needed	---	Flowable	---	---	40	100
Flowable Fill non- excavatable	125	as needed	as needed	as needed	as needed	---	Flowable	---	---	100	as needed
Pavement	4500 Design, field	0.559	0.559	---	---	1.5 slip form	---	526	---	---	---
	650 flexural, design only										

Precast	See Table 1077-1	as needed	as needed	---	---	6.0	as needed	as needed	as needed	as needed	as needed
Prestressed	per contract	See Table 1078-1	See Table 1078-1	---	---	8.0	---	564	as needed	---	---

- A. The slump may be increased to 6 inches, provided the increase in slump is achieved by adding a chemical admixture conforming to Section 1024-3. In no case shall the water-cement ratio on the approved design be exceeded. Concrete exhibiting segregation and/or excessive bleeding will be rejected. Utilizing an Admixture to modify slump does not relinquish the contractor’s responsibility to ensure the final product quality and overall configuration meets design specifications. Caution should be taken when placing these modified mixes on steep grades to prevent unintended changes to the set slope.

MATERIAL AND EQUIPMENT STORAGE & PARKING OF PERSONAL VEHICLES:

11-17-21

1101

SP11 R03

Revise the *2018 Standard Specifications* as follows:

Page 11-2, Article 1101-8 MATERIAL AND EQUIPMENT STORAGE, line 35-38, delete and replace with the following:

When work is not in progress, keep all personnel, equipment, machinery, tools, construction debris, materials and supplies away from active travel lanes that meets Table 1101-1.

TABLE 1101-1 MATERIAL AND EQUIPMENT STORAGE FROM ACTIVE TRAVEL LANES	
Posted Speed Limit (mph)	Distance (ft)
40 or less	≥ 18
45-50	≥ 28
55	≥ 32
60 or higher	≥ 40

When vehicles, equipment and materials are protected by concrete barrier or guardrail, they shall be offset at least 5 feet from the barrier or guardrail.

Page 11-2, Article 1101-9 PARKING OF PERSONAL VEHICLES, line 40-41, delete and replace with the following:

Provide staging areas for personal vehicle parking in accordance with section 1101-8 or as directed by the Engineer before use.

WORK ZONE INSTALLER:

(7-20-21)

1101, 1150

SP11 R04

Provide the service of at least one qualified work zone installer during the setup, installation, and removal of temporary traffic control within the highway right of way. The qualified work zone installer shall serve as crew leader and shall be on site and directing the installation and removal of temporary traffic control. If multiple temporary traffic control installations or removals are occurring simultaneously, then each shall have a qualified work zone installer.

The work zone installer shall be qualified by an NCDOT approved training agency in the safe and competent set up of temporary traffic control. For a complete listing of approved training agencies, see the Work Zone Safety Training webpage.

A work zone supervisor, in accordance with Article 1101-13 of the *Standard Specifications*, may fulfill the role of the work zone installer during the setup, installation, and removal of temporary traffic control within the highway right of way provided they are on site and directing the installation and removal of temporary traffic control.

All other individuals participating in the setup, installation, and removal of temporary traffic control within the highway right of way shall be certified as a qualified flagger in accordance with Article 1150-3 of the *Standard Specifications*, even if flagging is not being performed as part of the traffic control.

Provide the name and contact information of all qualified work zone installers to the Engineer prior to or at the preconstruction conference. Additionally, provide a qualification statement that all other individuals participating in the setup, installation, and removal of temporary traffic control are qualified flaggers that have been properly trained through an NCDOT approved training agency.

STANDARD SPECIAL PROVISION
AVAILABILITY OF FUNDS – TERMINATION OF CONTRACTS

(5-20-08)

Z-2

General Statute 143C-6-11. (h) Highway Appropriation is hereby incorporated verbatim in this contract as follows:

(h) Amounts Encumbered. – Transportation project appropriations may be encumbered in the amount of allotments made to the Department of Transportation by the Director for the estimated payments for transportation project contract work to be performed in the appropriation fiscal year. The allotments shall be multiyear allotments and shall be based on estimated revenues and shall be subject to the maximum contract authority contained in *General Statute 143C-6-11(c)*. Payment for transportation project work performed pursuant to contract in any fiscal year other than the current fiscal year is subject to appropriations by the General Assembly. Transportation project contracts shall contain a schedule of estimated completion progress, and any acceleration of this progress shall be subject to the approval of the Department of Transportation provided funds are available. The State reserves the right to terminate or suspend any transportation project contract, and any transportation project contract shall be so terminated or suspended if funds will not be available for payment of the work to be performed during that fiscal year pursuant to the contract. In the event of termination of any contract, the contractor shall be given a written notice of termination at least 60 days before completion of scheduled work for which funds are available. In the event of termination, the contractor shall be paid for the work already performed in accordance with the contract specifications.

Payment will be made on any contract terminated pursuant to the special provision in accordance with Subarticle 108-13(D) of the *2018 Standard Specifications*.

STANDARD SPECIAL PROVISION**ERRATA**

(10-16-18) (Rev. 8-16-22)

Z-4

Revise the *2018 Standard Specifications* as follows:

Division 4

Page 4-84, Article 458-5 MEASUREMENT AND PAYMENT, line 31, replace article number “454-1” with “458-1”.

Division 6

Page 6-7, Article 609-1 DESCRIPTION, line 29, replace article number “609-10” with “609-9”.

Page 6-26, Subarticle 610-13(A)(1) Acceptance for New Construction, line 31, replace Table number “610-7” with “610-8”.

Page 6-29, Subarticle 610-13(B) North Carolina Hearne Straightedge, line 32, replace Table number “610-8” with “610-9”.

Page 6-31, Article 610-14 DENSITY ACCEPTANCE, Specified Density prior to line 30 and line 32, replace Table number “610-6” with “610-7”.

Division 7

Page 7-27, Article 725-1 MEASUREMENT AND PAYMENT, line 4, replace article number “725-1” with “724-4”.

Page 7-28, Article 725-1 MEASUREMENT AND PAYMENT, line 10, replace article number “725-1” with “725-3”.

Division 10

Page 10-37, Article 1012-4, LIGHTWEIGHT AGGREGATE, line 4, replace Table number “1012-8” with “1012-5”.

Page 10-78, Article 1056-4 GEOTEXTILES, TABLE 1056-1, Permittivity, Type 2, replace “Table 6^D” with “Table 7^D” and **Permittivity, Type 3^B,** replace “Table 7^D” with “Table 8^D”.

Page 10-121, Article 1076-7, REPAIR OF GALVANIZING, line 8, replace article number “1080-9” with “1080-7”.

Page 10-162, Article 1080-50 PAINT FOR VERTICAL MARKERS, line 1, replace article number “1080-50” with “1080-10”.

Page 10-162, Article 1080-61 EPOXY RESIN FOR REINFORCING STEEL, line 5, replace article number “1080-61” with “1080-11”.

Page 10-162, Article 1080-72 ABRASIVE MATERIALS FOR BLAST CLEANING STEEL, line 22, replace article number “1080-72” with “1080-12”.

Page 10-163, Article 1080-83 FIELD PERFORMANCE AND SERVICES, line 25, replace article number “1080-83” with “1080-13”.

Division 17

Page 17-15, Article 1715-4 MEASUREMENT AND PAYMENT, lines 42-44, replace the second sentence with the following:

An example is an installation of a single 1.25 inch HDPE conduit would be paid as:

Directional Drill (1)(1.25") Linear Foot

Page 17-15, Subarticle 1715-3(E) Bore and Jack, line 5, replace article number “1540-4” with “1550-4”.

Page 17-15, Subarticle 1715-3(E) Bore and Jack, lines 10 & 11, replace "*NCDOT Policies and Procedures for Accommodating Utilities on Highway Rights of Way*" with "*NCDOT Utilities Accommodations Manual*".

STANDARD SPECIAL PROVISION**PLANT AND PEST QUARANTINES**

(Imported Fire Ant, Gypsy Moth, Witchweed, Emerald Ash Borer, Guava Root Knot Nematode, And Other Noxious Weeds)

(3-18-03) (Rev. 5-21-19)

Z-04a

Within Quarantined Area

This project may be within a county regulated for plant and/or pests. If the project or any part of the Contractor's operations is located within a quarantined area, thoroughly clean all equipment prior to moving out of the quarantined area. Comply with federal/state regulations by obtaining a certificate or limited permit for any regulated article moving from the quarantined area.

Originating in a Quarantined County

Obtain a certificate or limited permit issued by the N.C. Department of Agriculture/United States Department of Agriculture. Have the certificate or limited permit accompany the article when it arrives at the project site.

Contact

Contact the N.C. Department of Agriculture/United States Department of Agriculture at 1-800-206-9333, 919-707-3730, or <https://www.ncagr.gov/plantindustry/Plant/quaran/table2.htm> to determine those specific project sites located in the quarantined area or for any regulated article used on this project originating in a quarantined county.

Regulated Articles Include

1. Soil, sand, gravel, compost, peat, humus, muck, and decomposed manure, separately or with other articles. This includes movement of articles listed above that may be associated with cut/waste, ditch pulling, and shoulder cutting.
2. Plants with roots including grass sod.
3. Plant crowns and roots.
4. Bulbs, corms, rhizomes, and tubers of ornamental plants.
5. Hay, straw, fodder, and plant litter of any kind.
6. Clearing and grubbing debris.
7. Used agricultural cultivating and harvesting equipment.
8. Used earth-moving equipment.
9. Any other products, articles, or means of conveyance, of any character, if determined by an inspector to present a hazard of spreading imported fire ant, gypsy moth, witchweed, emerald ash borer, guava root knot nematode, or other noxious weeds.

STANDARD SPECIAL PROVISION**TITLE VI AND NONDISCRIMINATION:**

(6-28-77)(Rev 6/19/2018)

Z-6

Revise the *2018 Standard Specifications* as follows:

Replace Article 103-4(B) with the following:

The North Carolina Department of Transportation is committed to carrying out the U.S. Department of Transportation's policy of ensuring nondiscrimination in the award and administration of contracts.

The provisions of this section related to United States Department of Transportation (US DOT) Order 1050.2A, Title 49 Code of Federal Regulations (CFR) part 21, 23 United States Code (U.S.C.) 140 and 23 CFR part 200 (or 49 CFR 303, 49 U.S.C. 5332 or 49 U.S.C. 47123) are applicable to all North Carolina Department of Transportation (NCDOT) contracts and to all related subcontracts, material supply, engineering, architectural and other service contracts, regardless of dollar amount. Any Federal provision that is specifically required not specifically set forth is hereby incorporated by reference.

(1) Title VI Assurances (USDOT Order 1050.2A, Appendix A)

During the performance of this contract, the contractor, for itself, its assignees, and successors in interest (hereinafter referred to as the "contractor") agrees as follows:

(a) Compliance with Regulations

The contractor (hereinafter includes consultants) shall comply with the Acts and the Regulations relative to Nondiscrimination in Federally-assisted programs of the U.S. Department of Transportation, Federal Highway Administration (FHWA), as they may be amended from time to time, which are herein incorporated by reference and made a part of this contract.

(b) Nondiscrimination

The contractor, with regard to the work performed by it during the contract, shall not discriminate on the grounds of race, color, or national origin in the selection and retention of subcontractors, including procurements of materials and leases of equipment. The contractor shall not participate directly or indirectly in the discrimination prohibited by the Acts and the Regulations, including employment practices when the contract covers any activity, project, or program set forth in Appendix B of 49 CFR Part 21.

(c) Solicitations for Subcontractors, Including Procurements of Materials and Equipment

In all solicitations, either by competitive bidding, or negotiation made by the contractor for work to be performed under a subcontract, including procurements of materials, or leases of equipment, each potential subcontractor or supplier shall be notified by the contractor of the contractor's obligations under this contract and the Acts and the Regulations relative to Nondiscrimination on the grounds of race, color, or national origin.

(d) Information and Reports

The contractor shall provide all information and reports required by the Acts, the Regulations, and directives issued pursuant thereto and shall permit access to its books, records, accounts, other sources of information, and its facilities as may be determined by the Recipient or the FHWA to be pertinent to ascertain compliance with such Acts, Regulations, and instructions. Where any information required of a contractor is in the exclusive possession of another who fails or refuses to furnish the information, the contractor shall so certify to the Recipient or the FHWA, as appropriate, and shall set forth what efforts it has made to obtain the information.

(e) Sanctions for Noncompliance:

In the event of a contractor's noncompliance with the Non-discrimination provisions of this contract, the Recipient will impose such contract sanctions as it and/or the FHWA may determine to be appropriate, including, but not limited to:

- (i) Withholding payments to the contractor under the contract until the contractor complies; and/or
 - (ii) Cancelling, terminating, or suspending a contract, in whole or in part.
- (f) Incorporation of Provisions

The contractor shall include the provisions of paragraphs (a) through (f) in every subcontract, including procurements of materials and leases of equipment, unless exempt by the Acts, the Regulations and directives issued pursuant thereto. The contractor shall take action with respect to any subcontract or procurement as the Recipient or the FHWA may direct as a means of enforcing such provisions including sanctions for noncompliance. Provided, that if the contractor becomes involved in, or is threatened with litigation by a subcontractor, or supplier because of such direction, the contractor may request the Recipient to enter into any litigation to protect the interests of the Recipient. In addition, the contractor may request the United States to enter into the litigation to protect the interests of the United States.

(2) Title VI Nondiscrimination Program (23 CFR 200.5(p))

The North Carolina Department of Transportation (NCDOT) has assured the USDOT that, as a condition to receiving federal financial assistance, NCDOT will comply with Title VI of the Civil Rights Act of 1964 and all requirements imposed by Title 49 CFR part 21 and related nondiscrimination authorities to ensure that no person shall, on the ground of race, color, national origin, limited English proficiency, sex, age, or disability (including religion/creed or income-level, where applicable), be excluded from participation in, be denied the benefits of, or be subjected to discrimination under any programs, activities, or services conducted or funded by NCDOT. Contractors and other organizations under contract or agreement with NCDOT must also comply with Title VI and related authorities, therefore:

- (a) During the performance of this contract or agreement, contractors (e.g., subcontractors, consultants, vendors, prime contractors) are responsible for complying with NCDOT's Title VI Program. Contractors are not required to prepare or submit Title VI Programs. To comply with this section, the prime contractor shall:
 - 1. Post NCDOT's Notice of Nondiscrimination and the Contractor's own Equal Employment Opportunity (EEO) Policy in conspicuous locations accessible to all employees, applicants and subcontractors on the jobsite.
 - 2. Physically incorporate the required Title VI clauses into all subcontracts on federally-assisted and state-funded NCDOT projects, and ensure inclusion by subcontractors into all lower-tier subcontracts.
 - 3. Required Solicitation Language. The Contractor shall include the following notification in all solicitations for bids and requests for work or material, regardless of funding source:

“The North Carolina Department of Transportation, in accordance with the provisions of Title VI of the Civil Rights Act of 1964 (78 Stat. 252, 42 U.S.C. §§ 2000d to 2000d-4) and the Regulations, hereby notifies all bidders that it will affirmatively ensure that any contract entered into pursuant to this advertisement, disadvantaged business enterprises will be afforded full and fair opportunity to submit bids in response to this invitation and will not be discriminated against on the grounds of race, color, or national origin in consideration for an award. In accordance with other related nondiscrimination authorities, bidders and contractors will also not be discriminated against on the grounds of sex, age, disability, low-income level, creed/religion, or limited English proficiency in consideration for an award.”

4. Physically incorporate the FHWA-1273, in its entirety, into all subcontracts and subsequent lower tier subcontracts on Federal-aid highway construction contracts only.
 5. Provide language assistance services (i.e., written translation and oral interpretation), free of charge, to LEP employees and applicants. Contact NCDOT OCR for further assistance, if needed.
 6. For assistance with these Title VI requirements, contact the NCDOT Title VI Nondiscrimination Program at 1-800-522-0453.
- (b) Subrecipients (e.g. cities, counties, LGAs, planning organizations) may be required to prepare and submit a Title VI Plan to NCDOT, including Title VI Assurances and/or agreements. Subrecipients must also ensure compliance by their contractors and subrecipients with Title VI. (23 CFR 200.9(b)(7))
- (c) If reviewed or investigated by NCDOT, the contractor or subrecipient agrees to take affirmative action to correct any deficiencies found within a reasonable time period, not to exceed 90 calendar days, unless additional time is granted by NCDOT. (23 CFR 200.9(b)(15))
- (d) The Contractor is responsible for notifying subcontractors of NCDOT's External Discrimination Complaints Process.
1. **Applicability**
Title VI and related laws protect participants and beneficiaries (e.g., members of the public and contractors) from discrimination by NCDOT employees, subrecipients and contractors, regardless of funding source.
 2. **Eligibility**
Any person—or class of persons—who believes he/she has been subjected to discrimination based on race, color, national origin, Limited English Proficiency (LEP), sex, age, or disability (and religion in the context of employment, aviation, or transit) may file a written complaint. The law also prohibits intimidation or retaliation of any sort.
 3. **Time Limits and Filing Options**
Complaints may be filed by the affected individual(s) or a representative and must be filed no later than 180 calendar days after the following:
 - (i) The date of the alleged act of discrimination; or
 - (ii) The date when the person(s) became aware of the alleged discrimination; or
 - (iii) Where there has been a continuing course of conduct, the date on which that conduct was discontinued or the latest instance of the conduct.Title VI and related discrimination complaints may be submitted to the following entities:
 - North Carolina Department of Transportation, Office of Civil Rights, Title VI Program, 1511 Mail Service Center, Raleigh, NC 27699-1511; toll free 1-800-522-0453
 - Federal Highway Administration, North Carolina Division Office, 310 New Bern Avenue, Suite 410, Raleigh, NC 27601, 919-747-7010
 - US Department of Transportation, Departmental Office of Civil Rights, External Civil Rights Programs Division, 1200 New Jersey Avenue, SE, Washington, DC 20590; 202-366-4070
 4. **Format for Complaints**
Complaints must be in writing and signed by the complainant(s) or a representative, and include the complainant's name, address, and telephone number. Complaints received by fax or e-mail will be acknowledged and processed. Allegations received by telephone will be reduced to writing and provided to the complainant for confirmation or revision before processing. Complaints will be accepted in other languages, including Braille.
 5. **Discrimination Complaint Form**
Contact NCDOT Civil Rights to receive a full copy of the Discrimination Complaint Form and procedures.

6. Complaint Basis

Allegations must be based on issues involving race, color, national origin (LEP), sex, age, disability, or religion (in the context of employment, aviation or transit). “Basis” refers to the complainant’s membership in a protected group category.

TABLE 103-1 COMPLAINT BASIS			
Protected Categories	Definition	Examples	Applicable Nondiscrimination Authorities
Race and Ethnicity	An individual belonging to one of the accepted racial groups; or the perception, based usually on physical characteristics that a person is a member of a racial group	Black/African American, Hispanic/Latino, Asian, American Indian/Alaska Native, Native Hawaiian/Pacific Islander, White	Title VI of the Civil Rights Act of 1964; 49 CFR Part 21; 23 CFR 200; 49 U.S.C. 5332(b); 49 U.S.C. 47123. <i>(Executive Order 13166)</i>
Color	Color of skin, including shade of skin within a racial group	Black, White, brown, yellow, etc.	
National Origin <i>(Limited English Proficiency)</i>	Place of birth. Citizenship is not a factor. <i>(Discrimination based on language or a person’s accent is also covered)</i>	Mexican, Cuban, Japanese, Vietnamese, Chinese	
Sex	Gender. The sex of an individual. <i>Note: Sex under this program does not include sexual orientation.</i>	Women and Men	1973 Federal-Aid Highway Act; 49 U.S.C. 5332(b); 49 U.S.C. 47123.
Age	Persons of any age	21-year-old person	Age Discrimination Act of 1975 49 U.S.C. 5332(b); 49 U.S.C. 47123.
Disability	Physical or mental impairment, permanent or temporary, or perceived.	Blind, alcoholic, para-amputee, epileptic, diabetic, arthritic	Section 504 of the Rehabilitation Act of 1973; Americans with Disabilities Act of 1990
Religion (in the context of employment) <i>(Religion/ Creed in all aspects of any aviation or transit-related construction)</i>	An individual belonging to a religious group; or the perception, based on distinguishable characteristics that a person is a member of a religious group. In practice, actions taken as a result of the moral and ethical beliefs as to what is right and wrong, which are sincerely held with the strength of traditional religious views. <i>Note: Does not have to be associated with a recognized religious group or church; if an individual sincerely holds to the belief, it is a protected religious practice.</i>	Muslim, Christian, Sikh, Hindu, etc.	Title VII of the Civil Rights Act of 1964; 23 CFR 230; FHWA-1273 Required Contract Provisions. <i>(49 U.S.C. 5332(b); 49 U.S.C. 47123)</i>

(3) Pertinent Nondiscrimination Authorities

During the performance of this contract, the contractor, for itself, its assignees, and successors in interest agrees to comply with the following non-discrimination statutes and authorities, including, but not limited to:

- (a) Title VI of the Civil Rights Act of 1964 (42 U.S.C. § 2000d et seq., 78 stat. 252), (prohibits discrimination on the basis of race, color, national origin); and 49 CFR Part 21.
 - (b) The Uniform Relocation Assistance and Real Property Acquisition Policies Act of 1970, (42 U.S.C. § 4601), (prohibits unfair treatment of persons displaced or whose property has been acquired because of Federal or Federal-aid programs and projects);
 - (c) Federal-Aid Highway Act of 1973, (23 U.S.C. § 324 et seq.), (prohibits discrimination on the basis of sex);
 - (d) Section 504 of the Rehabilitation Act of 1973, (29 U.S.C. § 794 et seq.), as amended, (prohibits discrimination on the basis of disability) and 49 CFR Part 27;
 - (e) The Age Discrimination Act of 1975, as amended, (42 U.S.C. § 6101 et seq.), (prohibits discrimination on the basis of age);
 - (f) Airport and Airway Improvement Act of 1982, (49 USC § 471, Section 47123), as amended, (prohibits discrimination based on race, creed, color, national origin, or sex);
 - (g) The Civil Rights Restoration Act of 1987, (PL 100-209), (Broadened the scope, coverage and applicability of Title VI of the Civil Rights Act of 1964, The Age Discrimination Act of 1975 and Section 504 of the Rehabilitation Act of 1973, by expanding the definition of the terms "programs or activities" to include all of the programs or activities of the Federal-aid recipients, sub-recipients and contractors, whether such programs or activities are Federally funded or not);
 - (h) Titles II and III of the Americans with Disabilities Act, which prohibit discrimination on the basis of disability in the operation of public entities, public and private transportation systems, places of public accommodation, and certain testing entities (42 U.S.C. §§ 12131-12189) as implemented by Department of Transportation regulations at 49 C.F.R. parts 37 and 38;
 - (i) The Federal Aviation Administration's Nondiscrimination statute (49 U.S.C. § 47123) (prohibits discrimination on the basis of race, color, national origin, and sex);
 - (j) Executive Order 12898, Federal Actions to Address Environmental Justice in Minority Populations and Low-Income Populations, which ensures Nondiscrimination against minority populations by discouraging programs, policies, and activities with disproportionately high and adverse human health or environmental effects on minority and low-income populations;
 - (k) Executive Order 13166, Improving Access to Services for Persons with Limited English Proficiency, and resulting agency guidance, national origin discrimination includes discrimination because of Limited English proficiency (LEP). To ensure compliance with Title VI, you must take reasonable steps to ensure that LEP persons have meaningful access to your programs (70 Fed. Reg. at 74087 to 74100);
 - (l) Title IX of the Education Amendments of 1972, as amended, which prohibits you from discriminating because of sex in education programs or activities (20 U.S.C. 1681 et seq).
 - (m) Title VII of the Civil Rights Act of 1964 (42 U.S.C. § 2000e et seq., Pub. L. 88-352), (prohibits employment discrimination on the basis of race, color, religion, sex, or national origin).
- (4) Additional Title VI Assurances**
- **The following Title VI Assurances (Appendices B, C and D) shall apply, as applicable*
- (a) Clauses for Deeds Transferring United States Property (1050.2A, Appendix B)
The following clauses will be included in deeds effecting or recording the transfer of real property, structures, or improvements thereon, or granting interest therein from the United States pursuant to the provisions of Assurance 4.

NOW, THEREFORE, the U.S. Department of Transportation as authorized by law and upon the condition that the North Carolina Department of Transportation (NCDOT) will accept title to the lands and maintain the project constructed thereon in accordance with the North Carolina General Assembly, the Regulations for the Administration of the Federal-Aid Highway Program, and the policies and procedures prescribed by the Federal Highway Administration of the U.S. Department of Transportation in accordance and in compliance with all requirements imposed by Title 49, Code of Federal Regulations, U.S. Department of Transportation, Subtitle A, Office of the Secretary, Part 21, Nondiscrimination in Federally-assisted programs of the U.S. Department of Transportation pertaining to and effectuating the provisions of Title VI of the Civil Rights Act of 1964 (78 Stat. 252; 42 U.S.C. § 2000d to 2000d-4), does hereby remise, release, quitclaim and convey unto the NCDOT all the right, title and interest of the U.S. Department of Transportation in and to said lands described in Exhibit A attached hereto and made a part hereof.

(HABENDUM CLAUSE)

TO HAVE AND TO HOLD said lands and interests therein unto the North Carolina Department of Transportation (NCDOT) and its successors forever, subject, however, to the covenants, conditions, restrictions and reservations herein contained as follows, which will remain in effect for the period during which the real property or structures are used for a purpose for which Federal financial assistance is extended or for another purpose involving the provision of similar services or benefits and will be binding on the NCDOT, its successors and assigns.

The NCDOT, in consideration of the conveyance of said lands and interests in lands, does hereby covenant and agree as a covenant running with the land for itself, its successors and assigns, that (1) no person will on the grounds of race, color, or national origin, be excluded from participation in, be denied the benefits of, or be otherwise subjected to discrimination with regard to any facility located wholly or in part on, over, or under such lands hereby conveyed [,] [and]* (2) that the NCDOT will use the lands and interests in lands and interests in lands so conveyed, in compliance with all requirements imposed by or pursuant to Title 49, Code of Federal Regulations, U.S. Department of Transportation, Subtitle A, Office of the Secretary, Part 21, Non-discrimination in Federally-assisted programs of the U.S. Department of Transportation, Effectuation of Title VI of the Civil Rights Act of 1964, and as said Regulations and Acts may be amended [, and (3) that in the event of breach of any of the above-mentioned nondiscrimination conditions, the Department will have a right to enter or re-enter said lands and facilities on said land, and that above described land and facilities will thereon revert to and vest in and become the absolute property of the U.S. Department of Transportation and its assigns as such interest existed prior to this instruction].*

(*Reverter clause and related language to be used only when it is determined that such a clause is necessary in order to make clear the purpose of Title VI.)

- (b) Clauses for Transfer of Real Property Acquired or Improved Under the Activity, Facility, or Program (1050.2A, Appendix C)

The following clauses will be included in deeds, licenses, leases, permits, or similar instruments entered into by the North Carolina Department of Transportation (NCDOT) pursuant to the provisions of Assurance 7(a):

1. The (grantee, lessee, permittee, etc. as appropriate) for himself/herself, his/her heirs, personal representatives, successors in interest, and assigns, as a part of the consideration hereof, does hereby covenant and agree [in the case of deeds and leases add "as a covenant running with the land"] that:

- (i.) In the event facilities are constructed, maintained, or otherwise operated on the property described in this (deed, license, lease, permit, etc.) for a purpose for which a U.S. Department of Transportation activity, facility, or program is extended or for another purpose involving the provision of similar services or benefits, the (grantee, licensee, lessee, permittee, etc.) will maintain and operate such facilities and services in compliance with all requirements imposed by the Acts and Regulations (as may be amended) such that no person on the grounds of race, color, or national origin, will be excluded from participation in, denied the benefits of, or be otherwise subjected to discrimination in the use of said facilities.
2. With respect to licenses, leases, permits, etc., in the event of breach of any of the above Nondiscrimination covenants, the NCDOT will have the right to terminate the (lease, license, permit, etc.) and to enter, re-enter, and repossess said lands and facilities thereon, and hold the same as if the (lease, license, permit, etc.) had never been made or issued. *
3. With respect to a deed, in the event of breach of any of the above Nondiscrimination covenants, the NCDOT will have the right to enter or re-enter the lands and facilities thereon, and the above described lands and facilities will there upon revert to and vest in and become the absolute property of the NCDOT and its assigns. *

(*Reverter clause and related language to be used only when it is determined that such a clause is necessary to make clear the purpose of Title VI.)

(c) Clauses for Construction/Use/Access to Real Property Acquired Under the Activity, Facility or Program (1050.2A, Appendix D)

The following clauses will be included in deeds, licenses, permits, or similar instruments/agreements entered into by the North Carolina Department of Transportation (NCDOT) pursuant to the provisions of Assurance 7(b):

1. The (grantee, licensee, permittee, etc., as appropriate) for himself/herself, his/her heirs, personal representatives, successors in interest, and assigns, as a part of the consideration hereof, does hereby covenant and agree (in the case of deeds and leases add, "as a covenant running with the land") that (1) no person on the ground of race, color, or national origin, will be excluded from participation in, denied the benefits of, or be otherwise subjected to discrimination in the use of said facilities, (2) that in the construction of any improvements on, over, or under such land, and the furnishing of services thereon, no person on the ground of race, color, or national origin, will be excluded from participation in, denied the benefits of, or otherwise be subjected to discrimination, (3) that the (grantee, licensee, lessee, permittee, etc.) will use the premises in compliance with all other requirements imposed by or pursuant to the Acts and Regulations, as amended, set forth in this Assurance.
2. With respect to (licenses, leases, permits, etc.), in the event of breach of any of the above Non-discrimination covenants, the NCDOT will have the right to terminate the (license, permit, etc., as appropriate) and to enter or re-enter and repossess said land and the facilities thereon, and hold the same as if said (license, permit, etc., as appropriate) had never been made or issued. *
3. With respect to deeds, in the event of breach of any of the above Nondiscrimination covenants, the NCDOT will there upon revert to and vest in and become the absolute property of the NCDOT and its assigns. *

(*Reverter clause and related language to be used only when it is determined that such a clause is necessary to make clear the purpose of Title VI.)

STANDARD SPECIAL PROVISION**MINORITY AND FEMALE EMPLOYMENT REQUIREMENTS**

Z-7

NOTICE OF REQUIREMENTS FOR AFFIRMATIVE ACTION TO ENSURE EQUAL EMPLOYMENT OPPORTUNITY (*EXECUTIVE NUMBER 11246*)

1. The goals and timetables for minority and female participation, expressed in percentage terms for the Contractor's aggregate workforce in each trade on all construction work in the covered area, see as shown on the attached sheet entitled "Employment Goals for Minority and Female participation".

These goals are applicable to all the Contractor's construction work (whether or not it is Federal or federally assisted) performed in the covered area. If the Contractor performs construction work in a geographical area located outside of the covered area, it shall apply the goals established for such geographical area where the work is actually performed. With regard to this second area, the Contractor also is subject to the goals for both its federally involved and nonfederally involved construction.

The Contractor's compliance with the Executive Order and the regulations in *41 CFR Part 60-4* shall be based on its implementation of the Equal Opportunity Clause, specific affirmative action obligations required by the specifications set forth in *41 CFR 60-4.3(a)*, and its effort to meet the goals. The hours of minority and female employment and training must be substantially uniform throughout the length of the contract, and in each trade and the Contractor shall make a good faith effort to employ minorities and women evenly on each of its projects. The transfer of minority or female employees or trainees from Contractor to Contractor or from project to project for the sole purpose of meeting the Contractor's goals shall be a violation of the contract, the executive Order and the regulations in *41 CFR Part 60-4*. Compliance with the goals will be measured against the total work hours performed.

2. As used in this Notice and in the contract resulting from this solicitation, the "covered area" is the county or counties shown on the cover sheet of the proposal form and contract.

**EMPLOYMENT GOALS FOR MINORITY
AND FEMALE PARTICIPATION**

Economic Areas

Area 023 29.7%

Bertie County
Camden County
Chowan County
Gates County
Hertford County
Pasquotank County
Perquimans County

Area 024 31.7%

Beaufort County
Carteret County
Craven County
Dare County
Edgecombe County
Green County
Halifax County
Hyde County
Jones County
Lenoir County
Martin County
Nash County
Northampton County
Pamlico County
Pitt County
Tyrrell County
Washington County
Wayne County
Wilson County

Area 025 23.5%

Columbus County
Duplin County
Onslow County
Pender County

Area 026 33.5%

Bladen County
Hoke County
Richmond County
Robeson County
Sampson County
Scotland County

Area 027 24.7%

Chatham County
Franklin County
Granville County
Harnett County
Johnston County
Lee County
Person County
Vance County
Warren County

Area 028 15.5%

Alleghany County
Ashe County
Caswell County
Davie County
Montgomery County
Moore County
Rockingham County
Surry County
Watauga County
Wilkes County

Area 029 15.7%

Alexander County
Anson County
Burke County
Cabarrus County
Caldwell County
Catawba County
Cleveland County
Iredell County
Lincoln County
Polk County
Rowan County
Rutherford County
Stanly County

Area 0480 8.5%

Buncombe County
Madison County

Area 030 6.3%

Avery County
Cherokee County
Clay County
Graham County
Haywood County
Henderson County
Jackson County
McDowell County
Macon County
Mitchell County
Swain County
Transylvania County
Yancey County

SMSA Areas

Area 5720 26.6%

Currituck County

Area 9200 20.7%

Brunswick County

New Hanover County

Area 2560 24.2%

Cumberland County

Area 6640 22.8%

Durham County

Orange County

Wake County

Area 1300 16.2%

Alamance County

Area 3120 16.4%

Davidson County

Forsyth County

Guilford County

Randolph County

Stokes County

Yadkin County

Area 1520 18.3%

Gaston County

Mecklenburg County

Union County

Goals for Female

Participation in Each Trade

(Statewide) 6.9%

STANDARD SPECIAL PROVISION

REQUIRED CONTRACT PROVISIONS FEDERAL - AID CONSTRUCTION CONTRACTS

FHWA - 1273 Electronic Version - May 1, 2012

Z-8

- I. General
- II. Nondiscrimination
- III. Nonsegregated Facilities
- IV. Davis-Bacon and Related Act Provisions
- V. Contract Work Hours and Safety Standards Act Provisions
- VI. Subletting or Assigning the Contract
- VII. Safety: Accident Prevention
- VIII. False Statements Concerning Highway Projects
- IX. Implementation of Clean Air Act and Federal Water Pollution Control Act
- X. Compliance with Governmentwide Suspension and Debarment Requirements
- XI. Certification Regarding Use of Contract Funds for Lobbying

ATTACHMENTS

- A. Employment and Materials Preference for Appalachian Development Highway System or Appalachian Local Access Road Contracts (included in Appalachian contracts only)

I. GENERAL

1. Form FHWA-1273 must be physically incorporated in each construction contract funded under Title 23 (excluding emergency contracts solely intended for debris removal). The contractor (or subcontractor) must insert this form in each subcontract and further require its inclusion in all lower tier subcontracts (excluding purchase orders, rental agreements and other agreements for supplies or services).
The applicable requirements of Form FHWA-1273 are incorporated by reference for work done under any purchase order, rental agreement or agreement for other services. The prime contractor shall be responsible for compliance by any subcontractor, lower-tier subcontractor or service provider.
Form FHWA-1273 must be included in all Federal-aid design-build contracts, in all subcontracts and in lower tier subcontracts (excluding subcontracts for design services, purchase orders, rental agreements and other agreements for supplies or services). The design-builder shall be responsible for compliance by any subcontractor, lower-tier subcontractor or service provider.
Contracting agencies may reference Form FHWA-1273 in bid proposal or request for proposal documents, however, the Form FHWA-1273 must be physically incorporated (not referenced) in all contracts, subcontracts and lower-tier subcontracts (excluding purchase orders, rental agreements and other agreements for supplies or services related to a construction contract).
2. Subject to the applicability criteria noted in the following sections, these contract provisions shall apply to all work performed on the contract by the contractor's own organization and with the assistance of workers under the contractor's immediate superintendence and to all work performed on the contract by piecework, station work, or by subcontract.
3. A breach of any of the stipulations contained in these Required Contract Provisions may be sufficient grounds for withholding of progress payments, withholding of final payment, termination of the contract, suspension / debarment or any other action determined to be appropriate by the contracting agency and FHWA.
4. Selection of Labor: During the performance of this contract, the contractor shall not use convict labor for any purpose within the limits of a construction project on a Federal-aid highway unless it is labor performed by convicts who are on parole, supervised release, or probation. The term Federal-aid highway does not include roadways functionally classified as local roads or rural minor collectors.

II. NONDISCRIMINATION

The provisions of this section related to 23 CFR Part 230 are applicable to all Federal-aid construction contracts and to all related construction subcontracts of \$10,000 or more. The provisions of 23 CFR Part 230 are not applicable to material supply, engineering, or architectural service contracts.

In addition, the contractor and all subcontractors must comply with the following policies: Executive Order 11246, 41 CFR 60, 29 CFR 1625-1627, Title 23 USC Section 140, the Rehabilitation Act of 1973, as amended (29 USC 794), Title VI of the Civil Rights Act of 1964, as amended, and related regulations including 49 CFR Parts 21, 26 and 27; and 23 CFR Parts 200, 230, and 633.

The contractor and all subcontractors must comply with: the requirements of the Equal Opportunity Clause in 41 CFR 60-1.4(b) and, for all construction contracts exceeding \$10,000, the Standard Federal Equal Employment Opportunity Construction Contract Specifications in 41 CFR 60-4.3.

Note: The U.S. Department of Labor has exclusive authority to determine compliance with Executive Order 11246 and the policies of the Secretary of Labor including 41 CFR 60, and 29 CFR 1625-1627. The contracting agency and the FHWA have the authority and the responsibility to ensure compliance with Title 23 USC Section 140, the Rehabilitation Act of 1973, as amended (29 USC 794), and Title VI of the Civil Rights Act of 1964, as amended, and related regulations including 49 CFR Parts 21, 26 and 27; and 23 CFR Parts 200, 230, and 633.

The following provision is adopted from 23 CFR 230, Appendix A, with appropriate revisions to conform to the U.S. Department of Labor (US DOL) and FHWA requirements.

1. **Equal Employment Opportunity:** Equal employment opportunity (EEO) requirements not to discriminate and to take affirmative action to assure equal opportunity as set forth under laws, executive orders, rules, regulations (28 CFR 35, 29 CFR 1630, 29 CFR 1625-1627, 41 CFR 60 and 49 CFR 27) and orders of the Secretary of Labor as modified by the provisions prescribed herein, and imposed pursuant to 23 U.S.C. 140 shall constitute the EEO and specific affirmative action standards for the contractor's project activities under this contract. The provisions of the Americans with Disabilities Act of 1990 (42 U.S.C. 12101 et seq.) set forth under 28 CFR 35 and 29 CFR 1630 are incorporated by reference in this contract. In the execution of this contract, the contractor agrees to comply with the following minimum specific requirement activities of EEO:

- a. The contractor will work with the contracting agency and the Federal Government to ensure that it has made every good faith effort to provide equal opportunity with respect to all of its terms and conditions of employment and in their review of activities under the contract.
- b. The contractor will accept as its operating policy the following statement:
"It is the policy of this Company to assure that applicants are employed, and that employees are treated during employment, without regard to their race, religion, sex, color, national origin, age or disability. Such action shall include: employment, upgrading, demotion, or transfer; recruitment or recruitment advertising; layoff or termination; rates of pay or other forms of compensation; and selection for training, including apprenticeship, pre-apprenticeship, and/or on-the-job training."
2. **EEO Officer:** The contractor will designate and make known to the contracting officers an EEO Officer who will have the responsibility for and must be capable of effectively administering and promoting an active EEO program and who must be assigned adequate authority and responsibility to do so.
3. **Dissemination of Policy:** All members of the contractor's staff who are authorized to hire, supervise, promote, and discharge employees, or who recommend such action, or who are substantially involved in such action, will be made fully cognizant of, and will implement, the contractor's EEO policy and contractual responsibilities to provide EEO in each grade and classification of employment. To ensure that the above agreement will be met, the following actions will be taken as a minimum:
 - a. Periodic meetings of supervisory and personnel office employees will be conducted before the start of work and then not less often than once every six months, at which time the contractor's EEO policy and its implementation will be reviewed and explained. The meetings will be conducted by the EEO Officer.
 - b. All new supervisory or personnel office employees will be given a thorough indoctrination by the EEO Officer, covering all major aspects of the contractor's EEO obligations within thirty days following their reporting for duty with the contractor.
 - c. All personnel who are engaged in direct recruitment for the project will be instructed by the EEO Officer in the contractor's procedures for locating and hiring minorities and women.
 - d. Notices and posters setting forth the contractor's EEO policy will be placed in areas readily accessible to employees, applicants for employment and potential employees.
 - e. The contractor's EEO policy and the procedures to implement such policy will be brought to the attention of employees by means of meetings, employee handbooks, or other appropriate means.
4. **Recruitment:** When advertising for employees, the contractor will include in all advertisements for employees the notation: "An Equal Opportunity Employer." All such advertisements will be placed in publications having a large circulation among minorities and women in the area from which the project work force would normally be derived.
 - a. The contractor will, unless precluded by a valid bargaining agreement, conduct systematic and direct recruitment through public and private employee referral sources likely to yield qualified minorities and women. To meet this requirement, the contractor will identify sources of potential minority group employees, and establish with such identified sources procedures whereby minority and women applicants may be referred to the contractor for employment consideration.
 - b. In the event the contractor has a valid bargaining agreement providing for exclusive hiring hall referrals, the contractor is expected to observe the provisions of that agreement to the extent that the system meets the contractor's compliance with EEO contract provisions. Where implementation of such an agreement has the effect of discriminating against minorities or women, or obligates the contractor to do the same, such implementation violates Federal nondiscrimination provisions.
 - c. The contractor will encourage its present employees to refer minorities and women as applicants for employment. Information and procedures with regard to referring such applicants will be discussed with employees.
5. **Personnel Actions:** Wages, working conditions, and employee benefits shall be established and administered, and personnel actions of every type, including hiring, upgrading, promotion, transfer, demotion, layoff, and termination, shall be taken without regard to race, color, religion, sex, national origin, age or disability. The following procedures shall be followed:
 - a. The contractor will conduct periodic inspections of project sites to insure that working conditions and employee facilities do not indicate discriminatory treatment of project site personnel.
 - b. The contractor will periodically evaluate the spread of wages paid within each classification to determine any evidence of discriminatory wage practices.
 - c. The contractor will periodically review selected personnel actions in depth to determine whether there is evidence of discrimination. Where evidence is found, the contractor will promptly take corrective action. If the review indicates that the discrimination may extend beyond the actions reviewed, such corrective action shall include all affected persons.
 - d. The contractor will promptly investigate all complaints of alleged discrimination made to the contractor in connection with its obligations under this contract, will attempt to resolve such complaints, and will take appropriate corrective action within a reasonable time. If the investigation indicates that the discrimination may affect persons other than the complainant, such corrective action shall include such other persons. Upon completion of each investigation, the contractor will inform every complainant of all of their avenues of appeal.
6. **Training and Promotion:**
 - a. The contractor will assist in locating, qualifying, and increasing the skills of minorities and women who are applicants for employment or current employees. Such efforts should be aimed at developing full journey level status employees in the type of trade or job classification involved.
 - b. Consistent with the contractor's work force requirements and as permissible under Federal and State regulations, the contractor shall make full use of training programs, i.e., apprenticeship, and on-the-job training programs for the geographical area of contract performance. In the event a special provision for training is provided under this contract, this subparagraph will be superseded as indicated in the special provision. The contracting agency may reserve training positions for persons who receive welfare assistance in accordance with 23 U.S.C. 140(a).
 - c. The contractor will advise employees and applicants for employment of available training programs and entrance requirements for each.
 - d. The contractor will periodically review the training and promotion potential of employees who are minorities and women and will encourage eligible employees to apply for such training and promotion.

7. **Unions:** If the contractor relies in whole or in part upon unions as a source of employees, the contractor will use good faith efforts to obtain the cooperation of such unions to increase opportunities for minorities and women. Actions by the contractor, either directly or through a contractor's association acting as agent, will include the procedures set forth below:
 - a. The contractor will use good faith efforts to develop, in cooperation with the unions, joint training programs aimed toward qualifying more minorities and women for membership in the unions and increasing the skills of minorities and women so that they may qualify for higher paying employment.
 - b. The contractor will use good faith efforts to incorporate an EEO clause into each union agreement to the end that such union will be contractually bound to refer applicants without regard to their race, color, religion, sex, national origin, age or disability.
 - c. The contractor is to obtain information as to the referral practices and policies of the labor union except that to the extent such information is within the exclusive possession of the labor union and such labor union refuses to furnish such information to the contractor, the contractor shall so certify to the contracting agency and shall set forth what efforts have been made to obtain such information.
 - d. In the event the union is unable to provide the contractor with a reasonable flow of referrals within the time limit set forth in the collective bargaining agreement, the contractor will, through independent recruitment efforts, fill the employment vacancies without regard to race, color, religion, sex, national origin, age or disability; making full efforts to obtain qualified and/or qualifiable minorities and women. The failure of a union to provide sufficient referrals (even though it is obligated to provide exclusive referrals under the terms of a collective bargaining agreement) does not relieve the contractor from the requirements of this paragraph. In the event the union referral practice prevents the contractor from meeting the obligations pursuant to Executive Order 11246, as amended, and these special provisions, such contractor shall immediately notify the contracting agency.
8. **Reasonable Accommodation for Applicants / Employees with Disabilities:** The contractor must be familiar with the requirements for and comply with the Americans with Disabilities Act and all rules and regulations established there under. Employers must provide reasonable accommodation in all employment activities unless to do so would cause an undue hardship.
9. **Selection of Subcontractors, Procurement of Materials and Leasing of Equipment:** The contractor shall not discriminate on the grounds of race, color, religion, sex, national origin, age or disability in the selection and retention of subcontractors, including procurement of materials and leases of equipment. The contractor shall take all necessary and reasonable steps to ensure nondiscrimination in the administration of this contract.
 - a. The contractor shall notify all potential subcontractors and suppliers and lessors of their EEO obligations under this contract.
 - b. The contractor will use good faith efforts to ensure subcontractor compliance with their EEO obligations.
10. **Assurance Required by 49 CFR 26.13(b):**
 - a. The requirements of 49 CFR Part 26 and the State DOT's U.S. DOT-approved DBE program are incorporated by reference.
 - b. The contractor or subcontractor shall not discriminate on the basis of race, color, national origin, or sex in the performance of this contract. The contractor shall carry out applicable requirements of 49 CFR Part 26 in the award and administration of DOT-assisted contracts. Failure by the contractor to carry out these requirements is a material breach of this contract, which may result in the termination of this contract or such other remedy as the contracting agency deems appropriate.
11. **Records and Reports:** The contractor shall keep such records as necessary to document compliance with the EEO requirements. Such records shall be retained for a period of three years following the date of the final payment to the contractor for all contract work and shall be available at reasonable times and places for inspection by authorized representatives of the contracting agency and the FHWA.
 - a. The records kept by the contractor shall document the following:
 - (1) The number and work hours of minority and non-minority group members and women employed in each work classification on the project;
 - (2) The progress and efforts being made in cooperation with unions, when applicable, to increase employment opportunities for minorities and women; and
 - (3) The progress and efforts being made in locating, hiring, training, qualifying, and upgrading minorities and women;
 - b. The contractors and subcontractors will submit an annual report to the contracting agency each July for the duration of the project, indicating the number of minority, women, and non-minority group employees currently engaged in each work classification required by the contract work. This information is to be reported on Form FHWA-1391. The staffing data should represent the project work force on board in all or any part of the last payroll period preceding the end of July. If on-the-job training is being required by special provision, the contractor will be required to collect and report training data. The employment data should reflect the work force on board during all or any part of the last payroll period preceding the end of July.

III. NONSEGREGATED FACILITIES

This provision is applicable to all Federal-aid construction contracts and to all related construction subcontracts of \$10,000 or more.

The contractor must ensure that facilities provided for employees are provided in such a manner that segregation on the basis of race, color, religion, sex, or national origin cannot result. The contractor may neither require such segregated use by written or oral policies nor tolerate such use by employee custom. The contractor's obligation extends further to ensure that its employees are not assigned to perform their services at any location, under the contractor's control, where the facilities are segregated. The term "facilities" includes waiting rooms, work areas, restaurants and other eating areas, time clocks, restrooms, washrooms, locker rooms, and other storage or dressing areas, parking lots, drinking fountains, recreation or entertainment areas, transportation, and housing provided for employees. The contractor shall provide separate or single-user restrooms and necessary dressing or sleeping areas to assure privacy between sexes.

IV. DAVIS-BACON AND RELATED ACT PROVISIONS

This section is applicable to all Federal-aid construction projects exceeding \$2,000 and to all related subcontracts and lower-tier subcontracts (regardless of subcontract size). The requirements apply to all projects located within the right-of-way of a roadway that is functionally classified as Federal-aid highway. This excludes roadways functionally classified as local roads or rural minor collectors, which are exempt. Contracting agencies may elect to apply these requirements to other projects.

The following provisions are from the U.S. Department of Labor regulations in 29 CFR 5.5 "Contract provisions and related matters" with minor revisions to conform to the FHWA-1273 format and FHWA program requirements.

1. Minimum wages

- a. All laborers and mechanics employed or working upon the site of the work, will be paid unconditionally and not less often than once a week, and without subsequent deduction or rebate on any account (except such payroll deductions as are permitted by regulations issued by the Secretary of Labor under the Copeland Act (29 CFR part 3)), the full amount of wages and bona fide fringe benefits (or cash equivalents

thereof) due at time of payment computed at rates not less than those contained in the wage determination of the Secretary of Labor which is attached hereto and made a part hereof, regardless of any contractual relationship which may be alleged to exist between the contractor and such laborers and mechanics.

Contributions made or costs reasonably anticipated for bona fide fringe benefits under section 1(b)(2) of the Davis-Bacon Act on behalf of laborers or mechanics are considered wages paid to such laborers or mechanics, subject to the provisions of paragraph 1.d. of this section; also, regular contributions made or costs incurred for more than a weekly period (but not less often than quarterly) under plans, funds, or programs which cover the particular weekly period, are deemed to be constructively made or incurred during such weekly period. Such laborers and mechanics shall be paid the appropriate wage rate and fringe benefits on the wage determination for the classification of work actually performed, without regard to skill, except as provided in 29 CFR 5.5(a)(4). Laborers or mechanics performing work in more than one classification may be compensated at the rate specified for each classification for the time actually worked therein: Provided, That the employer's payroll records accurately set forth the time spent in each classification in which work is performed. The wage determination (including any additional classification and wage rates conformed under paragraph 1.b. of this section) and the Davis-Bacon poster (WH-1321) shall be posted at all times by the contractor and its subcontractors at the site of the work in a prominent and accessible place where it can be easily seen by the workers.

- b. (1) The contracting officer shall require that any class of laborers or mechanics, including helpers, which is not listed in the wage determination and which is to be employed under the contract shall be classified in conformance with the wage determination. The contracting officer shall approve an additional classification and wage rate and fringe benefits therefore only when the following criteria have been met:
 - (i) The work to be performed by the classification requested is not performed by a classification in the wage determination; and
 - (ii) The classification is utilized in the area by the construction industry; and
 - (iii) The proposed wage rate, including any bona fide fringe benefits, bears a reasonable relationship to the wage rates contained in the wage determination.
 - (2) If the contractor and the laborers and mechanics to be employed in the classification (if known), or their representatives, and the contracting officer agree on the classification and wage rate (including the amount designated for fringe benefits where appropriate), a report of the action taken shall be sent by the contracting officer to the Administrator of the Wage and Hour Division, Employment Standards Administration, U.S. Department of Labor, Washington, DC 20210. The Administrator, or an authorized representative, will approve, modify, or disapprove every additional classification action within 30 days of receipt and so advise the contracting officer or will notify the contracting officer within the 30-day period that additional time is necessary.
 - (3) In the event the contractor, the laborers or mechanics to be employed in the classification or their representatives, and the contracting officer do not agree on the proposed classification and wage rate (including the amount designated for fringe benefits, where appropriate), the contracting officer shall refer the questions, including the views of all interested parties and the recommendation of the contracting officer, to the Wage and Hour Administrator for determination. The Wage and Hour Administrator, or an authorized representative, will issue a determination within 30 days of receipt and so advise the contracting officer or will notify the contracting officer within the 30-day period that additional time is necessary.
 - (4) The wage rate (including fringe benefits where appropriate) determined pursuant to paragraphs 1.b.(2) or 1.b.(3) of this section, shall be paid to all workers performing work in the classification under this contract from the first day on which work is performed in the classification.
- c. Whenever the minimum wage rate prescribed in the contract for a class of laborers or mechanics includes a fringe benefit which is not expressed as an hourly rate, the contractor shall either pay the benefit as stated in the wage determination or shall pay another bona fide fringe benefit or an hourly cash equivalent thereof.
 - d. If the contractor does not make payments to a trustee or other third person, the contractor may consider as part of the wages of any laborer or mechanic the amount of any costs reasonably anticipated in providing bona fide fringe benefits under a plan or program, Provided, That the Secretary of Labor has found, upon the written request of the contractor, that the applicable standards of the Davis-Bacon Act have been met. The Secretary of Labor may require the contractor to set aside in a separate account assets for the meeting of obligations under the plan or program.
2. **Withholding.** The contracting agency shall upon its own action or upon written request of an authorized representative of the Department of Labor, withhold or cause to be withheld from the contractor under this contract, or any other Federal contract with the same prime contractor, or any other federally-assisted contract subject to Davis-Bacon prevailing wage requirements, which is held by the same prime contractor, so much of the accrued payments or advances as may be considered necessary to pay laborers and mechanics, including apprentices, trainees, and helpers, employed by the contractor or any subcontractor the full amount of wages required by the contract. In the event of failure to pay any laborer or mechanic, including any apprentice, trainee, or helper, employed or working on the site of the work, all or part of the wages required by the contract, the contracting agency may, after written notice to the contractor, take such action as may be necessary to cause the suspension of any further payment, advance, or guarantee of funds until such violations have ceased.
 3. **Payrolls and basic records**
 - a. Payrolls and basic records relating thereto shall be maintained by the contractor during the course of the work and preserved for a period of three years thereafter for all laborers and mechanics working at the site of the work. Such records shall contain the name, address, and social security number of each such worker, his or her correct classification, hourly rates of wages paid (including rates of contributions or costs anticipated for bona fide fringe benefits or cash equivalents thereof of the types described in section 1(b)(2)(B) of the Davis-Bacon Act), daily and weekly number of hours worked, deductions made and actual wages paid. Whenever the Secretary of Labor has found under 29 CFR 5.5(a)(1)(iv) that the wages of any laborer or mechanic include the amount of any costs reasonably anticipated in providing benefits under a plan or program described in section 1(b)(2)(B) of the Davis-Bacon Act, the contractor shall maintain records which show that the commitment to provide such benefits is enforceable, that the plan or program is financially responsible, and that the plan or program has been communicated in writing to the laborers or mechanics affected, and records which show the costs anticipated or the actual cost incurred in providing such benefits. Contractors employing apprentices or trainees under approved programs shall maintain written evidence of the registration of apprenticeship programs and certification of trainee programs, the registration of the apprentices and trainees, and the ratios and wage rates prescribed in the applicable programs.
 - b. (1) The contractor shall submit weekly for each week in which any contract work is performed a copy of all payrolls to the contracting agency. The payrolls submitted shall set out accurately and completely all of the information required to be maintained under 29 CFR 5.5(a)(3)(i), except that full social security numbers and home addresses shall not be included on weekly transmittals. Instead the payrolls shall only need to include an individually identifying number for each employee (e.g. , the last four digits of the employee's social security number). The required weekly payroll information may be submitted in any form desired. Optional Form WH-347 is available for

this purpose from the Wage and Hour Division Web site at <http://www.dol.gov/esa/whd/forms/wh347instr.htm> or its successor site. The prime contractor is responsible for the submission of copies of payrolls by all subcontractors. Contractors and subcontractors shall maintain the full social security number and current address of each covered worker, and shall provide them upon request to the contracting agency for transmission to the State DOT, the FHWA or the Wage and Hour Division of the Department of Labor for purposes of an investigation or audit of compliance with prevailing wage requirements. It is not a violation of this section for a prime contractor to require a subcontractor to provide addresses and social security numbers to the prime contractor for its own records, without weekly submission to the contracting agency.

- (2) Each payroll submitted shall be accompanied by a "Statement of Compliance," signed by the contractor or subcontractor or his or her agent who pays or supervises the payment of the persons employed under the contract and shall certify the following:
 - (i) That the payroll for the payroll period contains the information required to be provided under §5.5 (a)(3)(ii) of Regulations, 29 CFR part 5, the appropriate information is being maintained under §5.5 (a)(3)(i) of Regulations, 29 CFR part 5, and that such information is correct and complete;
 - (ii) That each laborer or mechanic (including each helper, apprentice, and trainee) employed on the contract during the payroll period has been paid the full weekly wages earned, without rebate, either directly or indirectly, and that no deductions have been made either directly or indirectly from the full wages earned, other than permissible deductions as set forth in Regulations, 29 CFR part 3;
 - (iii) That each laborer or mechanic has been paid not less than the applicable wage rates and fringe benefits or cash equivalents for the classification of work performed, as specified in the applicable wage determination incorporated into the contract.
 - (3) The weekly submission of a properly executed certification set forth on the reverse side of Optional Form WH-347 shall satisfy the requirement for submission of the "Statement of Compliance" required by paragraph 3.b.(2) of this section.
 - (4) The falsification of any of the above certifications may subject the contractor or subcontractor to civil or criminal prosecution under section 1001 of title 18 and section 231 of title 31 of the United States Code.
- c. The contractor or subcontractor shall make the records required under paragraph 3.a. of this section available for inspection, copying, or transcription by authorized representatives of the contracting agency, the State DOT, the FHWA, or the Department of Labor, and shall permit such representatives to interview employees during working hours on the job. If the contractor or subcontractor fails to submit the required records or to make them available, the FHWA may, after written notice to the contractor, the contracting agency or the State DOT, take such action as may be necessary to cause the suspension of any further payment, advance, or guarantee of funds. Furthermore, failure to submit the required records upon request or to make such records available may be grounds for debarment action pursuant to 29 CFR 5.12.
4. **Apprentices and trainees**
- a. Apprentices (programs of the USDOL). Apprentices will be permitted to work at less than the predetermined rate for the work they performed when they are employed pursuant to and individually registered in a bona fide apprenticeship program registered with the U.S. Department of Labor, Employment and Training Administration, Office of Apprenticeship Training, Employer and Labor Services, or with a State Apprenticeship Agency recognized by the Office, or if a person is employed in his or her first 90 days of probationary employment as an apprentice in such an apprenticeship program, who is not individually registered in the program, but who has been certified by the Office of Apprenticeship Training, Employer and Labor Services or a State Apprenticeship Agency (where appropriate) to be eligible for probationary employment as an apprentice.

The allowable ratio of apprentices to journeymen on the job site in any craft classification shall not be greater than the ratio permitted to the contractor as to the entire work force under the registered program. Any worker listed on a payroll at an apprentice wage rate, who is not registered or otherwise employed as stated above, shall be paid not less than the applicable wage rate on the wage determination for the classification of work actually performed. In addition, any apprentice performing work on the job site in excess of the ratio permitted under the registered program shall be paid not less than the applicable wage rate on the wage determination for the work actually performed. Where a contractor is performing construction on a project in a locality other than that in which its program is registered, the ratios and wage rates (expressed in percentages of the journeyman's hourly rate) specified in the contractor's or subcontractor's registered program shall be observed.

Every apprentice must be paid at not less than the rate specified in the registered program for the apprentice's level of progress, expressed as a percentage of the journeymen hourly rate specified in the applicable wage determination. Apprentices shall be paid fringe benefits in accordance with the provisions of the apprenticeship program. If the apprenticeship program does not specify fringe benefits, apprentices must be paid the full amount of fringe benefits listed on the wage determination for the applicable classification. If the Administrator determines that a different practice prevails for the applicable apprentice classification, fringes shall be paid in accordance with that determination.

In the event the Office of Apprenticeship Training, Employer and Labor Services, or a State Apprenticeship Agency recognized by the Office, withdraws approval of an apprenticeship program, the contractor will no longer be permitted to utilize apprentices at less than the applicable predetermined rate for the work performed until an acceptable program is approved.
 - b. Trainees (programs of the USDOL). Except as provided in 29 CFR 5.16, trainees will not be permitted to work at less than the predetermined rate for the work performed unless they are employed pursuant to and individually registered in a program which has received prior approval, evidenced by formal certification by the U.S. Department of Labor, Employment and Training Administration.

The ratio of trainees to journeymen on the job site shall not be greater than permitted under the plan approved by the Employment and Training Administration.

Every trainee must be paid at not less than the rate specified in the approved program for the trainee's level of progress, expressed as a percentage of the journeyman hourly rate specified in the applicable wage determination. Trainees shall be paid fringe benefits in accordance with the provisions of the trainee program. If the trainee program does not mention fringe benefits, trainees shall be paid the full amount of fringe benefits listed on the wage determination unless the Administrator of the Wage and Hour Division determines that there is an apprenticeship program associated with the corresponding journeyman wage rate on the wage determination which provides for less than full fringe benefits for apprentices. Any employee listed on the payroll at a trainee rate who is not registered and participating in a training plan approved by the Employment and Training Administration shall be paid not less than the applicable wage rate on the wage determination for the classification of work actually performed. In addition, any trainee performing work on the job site in excess of the ratio permitted under the registered program shall be paid not less than the applicable wage rate on the wage determination for the work actually performed.

In the event the Employment and Training Administration withdraws approval of a training program, the contractor will no longer be permitted to utilize trainees at less than the applicable predetermined rate for the work performed until an acceptable program is approved.
 - c. Equal employment opportunity. The utilization of apprentices, trainees and journeymen under this part shall be in conformity with the equal employment opportunity requirements of Executive Order 11246, as amended, and 29 CFR part 30.
 - d. Apprentices and Trainees (programs of the U.S. DOT). Apprentices and trainees working under apprenticeship and skill training programs which have been certified by the Secretary of Transportation as promoting EEO in connection with Federal-aid highway construction programs

are not subject to the requirements of paragraph 4 of this Section IV. The straight time hourly wage rates for apprentices and trainees under such programs will be established by the particular programs. The ratio of apprentices and trainees to journeymen shall not be greater than permitted by the terms of the particular program.

5. **Compliance with Copeland Act requirements.** The contractor shall comply with the requirements of 29 CFR part 3, which are incorporated by reference in this contract.
6. **Subcontracts.** The contractor or subcontractor shall insert Form FHWA-1273 in any subcontracts and also require the subcontractors to include Form FHWA-1273 in any lower tier subcontracts. The prime contractor shall be responsible for the compliance by any subcontractor or lower tier subcontractor with all the contract clauses in 29 CFR 5.5.
7. **Contract termination:** debarment. A breach of the contract clauses in 29 CFR 5.5 may be grounds for termination of the contract, and for debarment as a contractor and a subcontractor as provided in 29 CFR 5.12.
8. **Compliance with Davis-Bacon and Related Act requirements.** All rulings and interpretations of the Davis-Bacon and Related Acts contained in 29 CFR parts 1, 3, and 5 are herein incorporated by reference in this contract.
9. **Disputes concerning labor standards.** Disputes arising out of the labor standards provisions of this contract shall not be subject to the general disputes clause of this contract. Such disputes shall be resolved in accordance with the procedures of the Department of Labor set forth in 29 CFR parts 5, 6, and 7. Disputes within the meaning of this clause include disputes between the contractor (or any of its subcontractors) and the contracting agency, the U.S. Department of Labor, or the employees or their representatives.
10. **Certification of eligibility.**
 - a. By entering into this contract, the contractor certifies that neither it (nor he or she) nor any person or firm who has an interest in the contractor's firm is a person or firm ineligible to be awarded Government contracts by virtue of section 3(a) of the Davis-Bacon Act or 29 CFR 5.12(a)(1).
 - b. No part of this contract shall be subcontracted to any person or firm ineligible for award of a Government contract by virtue of section 3(a) of the Davis-Bacon Act or 29 CFR 5.12(a)(1).
 - c. The penalty for making false statements is prescribed in the U.S. Criminal Code, 18 U.S.C. 1001.

V. CONTRACT WORK HOURS AND SAFETY STANDARDS ACT

The following clauses apply to any Federal-aid construction contract in an amount in excess of \$100,000 and subject to the overtime provisions of the Contract Work Hours and Safety Standards Act. These clauses shall be inserted in addition to the clauses required by 29 CFR 5.5(a) or 29 CFR 4.6. As used in this paragraph, the terms laborers and mechanics include watchmen and guards.

1. **Overtime requirements.** No contractor or subcontractor contracting for any part of the contract work which may require or involve the employment of laborers or mechanics shall require or permit any such laborer or mechanic in any workweek in which he or she is employed on such work to work in excess of forty hours in such workweek unless such laborer or mechanic receives compensation at a rate not less than one and one-half times the basic rate of pay for all hours worked in excess of forty hours in such workweek.
2. **Violation; liability for unpaid wages; liquidated damages.** In the event of any violation of the clause set forth in paragraph (1.) of this section, the contractor and any subcontractor responsible therefor shall be liable for the unpaid wages. In addition, such contractor and subcontractor shall be liable to the United States (in the case of work done under contract for the District of Columbia or a territory, to such District or to such territory), for liquidated damages. Such liquidated damages shall be computed with respect to each individual laborer or mechanic, including watchmen and guards, employed in violation of the clause set forth in paragraph (1.) of this section, in the sum of \$10 for each calendar day on which such individual was required or permitted to work in excess of the standard workweek of forty hours without payment of the overtime wages required by the clause set forth in paragraph (1.) of this section.
3. **Withholding for unpaid wages and liquidated damages.** The FHWA or the contacting agency shall upon its own action or upon written request of an authorized representative of the Department of Labor withhold or cause to be withheld, from any moneys payable on account of work performed by the contractor or subcontractor under any such contract or any other Federal contract with the same prime contractor, or any other federally-assisted contract subject to the Contract Work Hours and Safety Standards Act, which is held by the same prime contractor, such sums as may be determined to be necessary to satisfy any liabilities of such contractor or subcontractor for unpaid wages and liquidated damages as provided in the clause set forth in paragraph (2.) of this section.
4. **Subcontracts.** The contractor or subcontractor shall insert in any subcontracts the clauses set forth in paragraph (1.) through (4.) of this section and also a clause requiring the subcontractors to include these clauses in any lower tier subcontracts. The prime contractor shall be responsible for compliance by any subcontractor or lower tier subcontractor with the clauses set forth in paragraphs (1.) through (4.) of this section.

VI. SUBLETTING OR ASSIGNING THE CONTRACT

This provision is applicable to all Federal-aid construction contracts on the National Highway System.

1. The contractor shall perform with its own organization contract work amounting to not less than 30 percent (or a greater percentage if specified elsewhere in the contract) of the total original contract price, excluding any specialty items designated by the contracting agency. Specialty items may be performed by subcontract and the amount of any such specialty items performed may be deducted from the total original contract price before computing the amount of work required to be performed by the contractor's own organization (23 CFR 635.116).
 - a. The term "perform work with its own organization" refers to workers employed or leased by the prime contractor, and equipment owned or rented by the prime contractor, with or without operators. Such term does not include employees or equipment of a subcontractor or lower tier subcontractor, agents of the prime contractor, or any other assignees. The term may include payments for the costs of hiring leased employees

from an employee leasing firm meeting all relevant Federal and State regulatory requirements. Leased employees may only be included in this term if the prime contractor meets all of the following conditions:

- (1) the prime contractor maintains control over the supervision of the day-to-day activities of the leased employees;
 - (2) the prime contractor remains responsible for the quality of the work of the leased employees;
 - (3) the prime contractor retains all power to accept or exclude individual employees from work on the project; and
 - (4) the prime contractor remains ultimately responsible for the payment of predetermined minimum wages, the submission of payrolls, statements of compliance and all other Federal regulatory requirements.
- b. "Specialty Items" shall be construed to be limited to work that requires highly specialized knowledge, abilities, or equipment not ordinarily available in the type of contracting organizations qualified and expected to bid or propose on the contract as a whole and in general are to be limited to minor components of the overall contract.
2. The contract amount upon which the requirements set forth in paragraph (1) of Section VI is computed includes the cost of material and manufactured products which are to be purchased or produced by the contractor under the contract provisions.
 3. The contractor shall furnish (a) a competent superintendent or supervisor who is employed by the firm, has full authority to direct performance of the work in accordance with the contract requirements, and is in charge of all construction operations (regardless of who performs the work) and (b) such other of its own organizational resources (supervision, management, and engineering services) as the contracting officer determines is necessary to assure the performance of the contract.
 4. No portion of the contract shall be sublet, assigned or otherwise disposed of except with the written consent of the contracting officer, or authorized representative, and such consent when given shall not be construed to relieve the contractor of any responsibility for the fulfillment of the contract. Written consent will be given only after the contracting agency has assured that each subcontract is evidenced in writing and that it contains all pertinent provisions and requirements of the prime contract.
 5. The 30% self-performance requirement of paragraph (1) is not applicable to design-build contracts; however, contracting agencies may establish their own self-performance requirements.

VII. SAFETY: ACCIDENT PREVENTION

This provision is applicable to all Federal-aid construction contracts and to all related subcontracts.

1. In the performance of this contract the contractor shall comply with all applicable Federal, State, and local laws governing safety, health, and sanitation (23 CFR 635). The contractor shall provide all safeguards, safety devices and protective equipment and take any other needed actions as it determines, or as the contracting officer may determine, to be reasonably necessary to protect the life and health of employees on the job and the safety of the public and to protect property in connection with the performance of the work covered by the contract.
2. It is a condition of this contract, and shall be made a condition of each subcontract, which the contractor enters into pursuant to this contract, that the contractor and any subcontractor shall not permit any employee, in performance of the contract, to work in surroundings or under conditions which are unsanitary, hazardous or dangerous to his/her health or safety, as determined under construction safety and health standards (29 CFR 1926) promulgated by the Secretary of Labor, in accordance with Section 107 of the Contract Work Hours and Safety Standards Act (40 U.S.C. 3704).
3. Pursuant to 29 CFR 1926.3, it is a condition of this contract that the Secretary of Labor or authorized representative thereof, shall have right of entry to any site of contract performance to inspect or investigate the matter of compliance with the construction safety and health standards and to carry out the duties of the Secretary under Section 107 of the Contract Work Hours and Safety Standards Act (40 U.S.C.3704).

VIII. FALSE STATEMENTS CONCERNING HIGHWAY PROJECTS

This provision is applicable to all Federal-aid construction contracts and to all related subcontracts.

In order to assure high quality and durable construction in conformity with approved plans and specifications and a high degree of reliability on statements and representations made by engineers, contractors, suppliers, and workers on Federal-aid highway projects, it is essential that all persons concerned with the project perform their functions as carefully, thoroughly, and honestly as possible. Willful falsification, distortion, or misrepresentation with respect to any facts related to the project is a violation of Federal law. To prevent any misunderstanding regarding the seriousness of these and similar acts, Form FHWA-1022 shall be posted on each Federal-aid highway project (23 CFR 635) in one or more places where it is readily available to all persons concerned with the project:

18 U.S.C. 1020 reads as follows:

"Whoever, being an officer, agent, or employee of the United States, or of any State or Territory, or whoever, whether a person, association, firm, or corporation, knowingly makes any false statement, false representation, or false report as to the character, quality, quantity, or cost of the material used or to be used, or the quantity or quality of the work performed or to be performed, or the cost thereof in connection with the submission of plans, maps, specifications, contracts, or costs of construction on any highway or related project submitted for approval to the Secretary of Transportation; or

Whoever knowingly makes any false statement, false representation, false report or false claim with respect to the character, quality, quantity, or cost of any work performed or to be performed, or materials furnished or to be furnished, in connection with the construction of any highway or related project approved by the Secretary of Transportation; or

Whoever knowingly makes any false statement or false representation as to material fact in any statement, certificate, or report submitted pursuant to provisions of the Federal-aid Roads Act approved July 1, 1916, (39 Stat. 355), as amended and supplemented;

Shall be fined under this title or imprisoned not more than 5 years or both."

IX. IMPLEMENTATION OF CLEAN AIR ACT AND FEDERAL WATER POLLUTION CONTROL ACT

This provision is applicable to all Federal-aid construction contracts and to all related subcontracts.

By submission of this bid/proposal or the execution of this contract, or subcontract, as appropriate, the bidder, proposer, Federal-aid construction contractor, or subcontractor, as appropriate, will be deemed to have stipulated as follows:

1. That any person who is or will be utilized in the performance of this contract is not prohibited from receiving an award due to a violation of Section 508 of the Clean Water Act or Section 306 of the Clean Air Act.
2. That the contractor agrees to include or cause to be included the requirements of paragraph (1) of this Section X in every subcontract, and further agrees to take such action as the contracting agency may direct as a means of enforcing such requirements.

X. CERTIFICATION REGARDING DEBARMENT, SUSPENSION, INELIGIBILITY AND VOLUNTARY EXCLUSION

This provision is applicable to all Federal-aid construction contracts, design-build contracts, subcontracts, lower-tier subcontracts, purchase orders, lease agreements, consultant contracts or any other covered transaction requiring FHWA approval or that is estimated to cost \$25,000 or more – as defined in 2 CFR Parts 180 and 1200.

1. Instructions for Certification – First Tier Participants:

- a. By signing and submitting this proposal, the prospective first tier participant is providing the certification set out below.
- b. The inability of a person to provide the certification set out below will not necessarily result in denial of participation in this covered transaction. The prospective first tier participant shall submit an explanation of why it cannot provide the certification set out below. The certification or explanation will be considered in connection with the department or agency's determination whether to enter into this transaction. However, failure of the prospective first tier participant to furnish a certification or an explanation shall disqualify such a person from participation in this transaction.
- c. The certification in this clause is a material representation of fact upon which reliance was placed when the contracting agency determined to enter into this transaction. If it is later determined that the prospective participant knowingly rendered an erroneous certification, in addition to other remedies available to the Federal Government, the contracting agency may terminate this transaction for cause of default.
- d. The prospective first tier participant shall provide immediate written notice to the contracting agency to whom this proposal is submitted if any time the prospective first tier participant learns that its certification was erroneous when submitted or has become erroneous by reason of changed circumstances.
- e. The terms "covered transaction," "debarred," "suspended," "ineligible," "participant," "person," "principal," and "voluntarily excluded," as used in this clause, are defined in 2 CFR Parts 180 and 1200. "First Tier Covered Transactions" refers to any covered transaction between a grantee or subgrantee of Federal funds and a participant (such as the prime or general contractor). "Lower Tier Covered Transactions" refers to any covered transaction under a First Tier Covered Transaction (such as subcontracts). "First Tier Participant" refers to the participant who has entered into a covered transaction with a grantee or subgrantee of Federal funds (such as the prime or general contractor). "Lower Tier Participant" refers any participant who has entered into a covered transaction with a First Tier Participant or other Lower Tier Participants (such as subcontractors and suppliers).
- f. The prospective first tier participant agrees by submitting this proposal that, should the proposed covered transaction be entered into, it shall not knowingly enter into any lower tier covered transaction with a person who is debarred, suspended, declared ineligible, or voluntarily excluded from participation in this covered transaction, unless authorized by the department or agency entering into this transaction.
- g. The prospective first tier participant further agrees by submitting this proposal that it will include the clause titled "Certification Regarding Debarment, Suspension, Ineligibility and Voluntary Exclusion-Lower Tier Covered Transactions," provided by the department or contracting agency, entering into this covered transaction, without modification, in all lower tier covered transactions and in all solicitations for lower tier covered transactions exceeding the \$25,000 threshold.
- h. A participant in a covered transaction may rely upon a certification of a prospective participant in a lower tier covered transaction that is not debarred, suspended, ineligible, or voluntarily excluded from the covered transaction, unless it knows that the certification is erroneous. A participant is responsible for ensuring that its principals are not suspended, debarred, or otherwise ineligible to participate in covered transactions. To verify the eligibility of its principals, as well as the eligibility of any lower tier prospective participants, each participant may, but is not required to, check the Excluded Parties List System website (<https://www.epls.gov/>), which is compiled by the General Services Administration.
- i. Nothing contained in the foregoing shall be construed to require the establishment of a system of records in order to render in good faith the certification required by this clause. The knowledge and information of the prospective participant is not required to exceed that which is normally possessed by a prudent person in the ordinary course of business dealings.
- j. Except for transactions authorized under paragraph (f) of these instructions, if a participant in a covered transaction knowingly enters into a lower tier covered transaction with a person who is suspended, debarred, ineligible, or voluntarily excluded from participation in this transaction, in addition to other remedies available to the Federal Government, the department or agency may terminate this transaction for cause or default.

* * * * *

2. Certification Regarding Debarment, Suspension, Ineligibility and Voluntary Exclusion – First Tier Participants:

- a. The prospective first tier participant certifies to the best of its knowledge and belief, that it and its principals:
 - (1) Are not presently debarred, suspended, proposed for debarment, declared ineligible, or voluntarily excluded from participating in covered transactions by any Federal department or agency;
 - (2) Have not within a three-year period preceding this proposal been convicted of or had a civil judgment rendered against them for commission of fraud or a criminal offense in connection with obtaining, attempting to obtain, or performing a public (Federal, State or local) transaction or contract under a public transaction; violation of Federal or State antitrust statutes or commission of embezzlement, theft, forgery, bribery, falsification or destruction of records, making false statements, or receiving stolen property;
 - (3) Are not presently indicted for or otherwise criminally or civilly charged by a governmental entity (Federal, State or local) with commission of any of the offenses enumerated in paragraph (a)(2) of this certification; and
 - (4) Have not within a three-year period preceding this application/proposal had one or more public transactions (Federal, State or local) terminated for cause or default.
- b. Where the prospective participant is unable to certify to any of the statements in this certification, such prospective participant shall attach an explanation to this proposal.

2. Instructions for Certification - Lower Tier Participants:

(Applicable to all subcontracts, purchase orders and other lower tier transactions requiring prior FHWA approval or estimated to cost \$25,000 or more - 2 CFR Parts 180 and 1200)

- a. By signing and submitting this proposal, the prospective lower tier is providing the certification set out below.
- b. The certification in this clause is a material representation of fact upon which reliance was placed when this transaction was entered into. If it is later determined that the prospective lower tier participant knowingly rendered an erroneous certification, in addition to other remedies

- available to the Federal Government, the department, or agency with which this transaction originated may pursue available remedies, including suspension and/or debarment.
- c. The prospective lower tier participant shall provide immediate written notice to the person to which this proposal is submitted if at any time the prospective lower tier participant learns that its certification was erroneous by reason of changed circumstances.
 - d. The terms "covered transaction," "debarred," "suspended," "ineligible," "participant," "person," "principal," and "voluntarily excluded," as used in this clause, are defined in 2 CFR Parts 180 and 1200. You may contact the person to which this proposal is submitted for assistance in obtaining a copy of those regulations. "First Tier Covered Transactions" refers to any covered transaction between a grantee or subgrantee of Federal funds and a participant (such as the prime or general contractor). "Lower Tier Covered Transactions" refers to any covered transaction under a First Tier Covered Transaction (such as subcontracts). "First Tier Participant" refers to the participant who has entered into a covered transaction with a grantee or subgrantee of Federal funds (such as the prime or general contractor). "Lower Tier Participant" refers any participant who has entered into a covered transaction with a First Tier Participant or other Lower Tier Participants (such as subcontractors and suppliers).
 - e. The prospective lower tier participant agrees by submitting this proposal that, should the proposed covered transaction be entered into, it shall not knowingly enter into any lower tier covered transaction with a person who is debarred, suspended, declared ineligible, or voluntarily excluded from participation in this covered transaction, unless authorized by the department or agency with which this transaction originated.
 - f. The prospective lower tier participant further agrees by submitting this proposal that it will include this clause titled "Certification Regarding Debarment, Suspension, Ineligibility and Voluntary Exclusion-Lower Tier Covered Transaction," without modification, in all lower tier covered transactions and in all solicitations for lower tier covered transactions exceeding the \$25,000 threshold.
 - g. A participant in a covered transaction may rely upon a certification of a prospective participant in a lower tier covered transaction that is not debarred, suspended, ineligible, or voluntarily excluded from the covered transaction, unless it knows that the certification is erroneous. A participant is responsible for ensuring that its principals are not suspended, debarred, or otherwise ineligible to participate in covered transactions. To verify the eligibility of its principals, as well as the eligibility of any lower tier prospective participants, each participant may, but is not required to, check the Excluded Parties List System website (<https://www.epls.gov/>), which is compiled by the General Services Administration.
 - h. Nothing contained in the foregoing shall be construed to require establishment of a system of records in order to render in good faith the certification required by this clause. The knowledge and information of participant is not required to exceed that which is normally possessed by a prudent person in the ordinary course of business dealings.
 - i. Except for transactions authorized under paragraph e of these instructions, if a participant in a covered transaction knowingly enters into a lower tier covered transaction with a person who is suspended, debarred, ineligible, or voluntarily excluded from participation in this transaction, in addition to other remedies available to the Federal Government, the department or agency with which this transaction originated may pursue available remedies, including suspension and/or debarment.

* * * * *

Certification Regarding Debarment, Suspension, Ineligibility and Voluntary Exclusion—Lower Tier Participants:

1. The prospective lower tier participant certifies, by submission of this proposal, that neither it nor its principals is presently debarred, suspended, proposed for debarment, declared ineligible, or voluntarily excluded from participating in covered transactions by any Federal department or agency.
2. Where the prospective lower tier participant is unable to certify to any of the statements in this certification, such prospective participant shall attach an explanation to this proposal.

* * * * *

XI. CERTIFICATION REGARDING USE OF CONTRACT FUNDS FOR LOBBYING

This provision is applicable to all Federal-aid construction contracts and to all related subcontracts which exceed \$100,000 (49 CFR 20).

1. The prospective participant certifies, by signing and submitting this bid or proposal, to the best of his or her knowledge and belief, that:
 - a. No Federal appropriated funds have been paid or will be paid, by or on behalf of the undersigned, to any person for influencing or attempting to influence an officer or employee of any Federal agency, a Member of Congress, an officer or employee of Congress, or an employee of a Member of Congress in connection with the awarding of any Federal contract, the making of any Federal grant, the making of any Federal loan, the entering into of any cooperative agreement, and the extension, continuation, renewal, amendment, or modification of any Federal contract, grant, loan, or cooperative agreement.
 - b. If any funds other than Federal appropriated funds have been paid or will be paid to any person for influencing or attempting to influence an officer or employee of any Federal agency, a Member of Congress, an officer or employee of Congress, or an employee of a Member of Congress in connection with this Federal contract, grant, loan, or cooperative agreement, the undersigned shall complete and submit Standard Form-LLL, "Disclosure Form to Report Lobbying," in accordance with its instructions.
2. This certification is a material representation of fact upon which reliance was placed when this transaction was made or entered into. Submission of this certification is a prerequisite for making or entering into this transaction imposed by 31 U.S.C. 1352. Any person who fails to file the required certification shall be subject to a civil penalty of not less than \$10,000 and not more than \$100,000 for each such failure.
3. The prospective participant also agrees by submitting its bid or proposal that the participant shall require that the language of this certification be included in all lower tier subcontracts, which exceed \$100,000 and that all such recipients shall certify and disclose accordingly.

STANDARD SPECIAL PROVISION**ON-THE-JOB TRAINING**

(10-16-07) (Rev. 4-21-15)

Z-10

Description

The North Carolina Department of Transportation will administer a custom version of the Federal On-the-Job Training (OJT) Program, commonly referred to as the Alternate OJT Program. All contractors (existing and newcomers) will be automatically placed in the Alternate Program. Standard OJT requirements typically associated with individual projects will no longer be applied at the project level. Instead, these requirements will be applicable on an annual basis for each contractor administered by the OJT Program Manager.

On the Job Training shall meet the requirements of 23 CFR 230.107 (b), 23 USC – Section 140, this provision and the On-the-Job Training Program Manual.

The Alternate OJT Program will allow a contractor to train employees on Federal, State and privately funded projects located in North Carolina. However, priority shall be given to training employees on NCDOT Federal-Aid funded projects.

Minorities and Women

Developing, training and upgrading of minorities and women toward journeyman level status is a primary objective of this special training provision. Accordingly, the Contractor shall make every effort to enroll minority and women as trainees to the extent that such persons are available within a reasonable area of recruitment. This training commitment is not intended, and shall not be used, to discriminate against any applicant for training, whether a member of a minority group or not.

Assigning Training Goals

The Department, through the OJT Program Manager, will assign training goals for a calendar year based on the contractors' past three years' activity and the contractors' anticipated upcoming year's activity with the Department. At the beginning of each year, all contractors eligible will be contacted by the Department to determine the number of trainees that will be assigned for the upcoming calendar year. At that time the Contractor shall enter into an agreement with the Department to provide a self-imposed on-the-job training program for the calendar year. This agreement will include a specific number of annual training goals agreed to by both parties. The number of training assignments may range from 1 to 15 per contractor per calendar year. The Contractor shall sign an agreement to fulfill their annual goal for the year.\

Training Classifications

The Contractor shall provide on-the-job training aimed at developing full journeyman level workers in the construction craft/operator positions. Preference shall be given to providing training in the following skilled work classifications:

Equipment Operators	Office Engineers
Truck Drivers	Estimators
Carpenters	Iron / Reinforcing Steel Workers
Concrete Finishers	Mechanics
Pipe Layers	Welders

The Department has established common training classifications and their respective training requirements that may be used by the contractors. However, the classifications established are not all-inclusive. Where the training is oriented toward construction applications, training will be allowed in lower-level management positions such as office engineers and estimators. Contractors shall submit new classifications for specific job functions that their employees are performing. The Department will review and recommend for acceptance to FHWA the new classifications proposed by contractors, if applicable. New classifications shall meet the following requirements:

Proposed training classifications are reasonable and realistic based on the job skill classification needs, and

The number of training hours specified in the training classification is consistent with common practices and provides enough time for the trainee to obtain journeyman level status.

The Contractor may allow trainees to be trained by a subcontractor provided that the Contractor retains primary responsibility for meeting the training and this provision is made applicable to the subcontract. However, only the Contractor will receive credit towards the annual goal for the trainee.

Where feasible, 25 percent of apprentices or trainees in each occupation shall be in their first year of apprenticeship or training. The number of trainees shall be distributed among the work classifications on the basis of the contractor's needs and the availability of journeymen in the various classifications within a reasonable area of recruitment.

No employee shall be employed as a trainee in any classification in which they have successfully completed a training course leading to journeyman level status or in which they have been employed as a journeyman.

Records and Reports

The Contractor shall maintain enrollment, monthly and completion reports documenting company compliance under these contract documents. These documents and any other information as requested shall be submitted to the OJT Program Manager.

Upon completion and graduation of the program, the Contractor shall provide each trainee with a certification Certificate showing the type and length of training satisfactorily completed.

Trainee Interviews

All trainees enrolled in the program will receive an initial and Trainee/Post graduate interview conducted by the OJT program staff.

Trainee Wages

Contractors shall compensate trainees on a graduating pay scale based upon a percentage of the prevailing minimum journeyman wages (Davis-Bacon Act). Minimum pay shall be as follows:

60 percent	of the journeyman wage for the first half of the training period
75 percent	of the journeyman wage for the third quarter of the training period
90 percent	of the journeyman wage for the last quarter of the training period

In no instance shall a trainee be paid less than the local minimum wage. The Contractor shall adhere to the minimum hourly wage rate that will satisfy both the NC Department of Labor (NCDOL) and the Department.

Achieving or Failing to Meet Training Goals

The Contractor will be credited for each trainee employed by him on the contract work who is currently enrolled or becomes enrolled in an approved program and who receives training for at least 50 percent of the specific program requirement. Trainees will be allowed to be transferred between projects if required by the Contractor's scheduled workload to meet training goals.

If a contractor fails to attain their training assignments for the calendar year, they may be taken off the NCDOT's Bidders List.

Measurement and Payment

No compensation will be made for providing required training in accordance with these contract documents.

STANDARD SPECIAL PROVISION
MINIMUM WAGES
GENERAL DECISION NC20220090 02/25/2022 NC90

Z-090

Date: February 25, 2022

General Decision Number: NC20220090 02/25/2022 NC90

Superseded General Decision Numbers: NC20210090

State: North Carolina

Construction Type: HIGHWAY

COUNTIES:

Brunswick	Greene	Onslow
Cumberland	Hoke	Pender
Currituck	Johnston	Pitt
Edgecombe	Nash	Wake
Franklin	New Hanover	Wayne

HIGHWAY CONSTRUCTION PROJECTS (excluding tunnels, building structures in rest area projects & railroad construction; bascule, suspension & spandrel arch bridges designed for commercial navigation, bridges involving marine construction; and other major bridges).

Note: Contracts subject to the Davis-Bacon Act are generally required to pay at least the applicable minimum wage rate required under Executive Order 14026 or Executive Order 13658. Please note that these Executive Orders apply to covered contracts entered into by the federal government that are subject to the Davis-Bacon Act itself, but do not apply to contracts subject only to the Davis-Bacon Related Acts, including those set forth at 29 CFR 5.1(a)(2)-(60).

<p>If the contract is entered into on or after January 30, 2022, or the contract is renewed or extended (e.g., an option is exercised) on or after January 30, 2022:</p>	<p>Executive Order 14026 generally applies to the contract.</p> <p>The contractor must pay all covered workers at least \$15.00 per hour (or the applicable wage rate listed on this wage determination, if it is higher) for all hours spent performing on that contract in 2022.</p>
<p>If the contract was awarded on or between January 1, 2015 and January 29, 2022, and the contract is not renewed or extended on or after January 30, 2022:</p>	<p>Executive Order 13658 generally applies to the contract.</p> <p>The contractor must pay all covered workers at least \$11.25 per hour (or the applicable wage rate listed on this wage determination, if it is higher) for all hours spent performing on that contract in 2022.</p>

The applicable Executive Order minimum wage rate will be adjusted annually. If this contract is covered by one of the Executive Orders and a classification considered necessary for performance

of work on the contract does not appear on this wage determination, the contractor must still submit a conformance request.

Additional information on contractor requirements and worker protections under the Executive Orders is available at <https://www.dol.gov/agencies/whd/government-contracts>.

Modification Number	Publication Date
0	01/07/2022
1	02/25/2022

SUNC2014-005 11/17/2014

	Rates	Fringes
BLASTER	21.04	
CARPENTER	13.72 **	
CEMENT MASON/CONCRETE FINISHER	14.48 **	
ELECTRICIAN		
Electrician	17.97	
Telecommunications Technician	16.79	.63
IRONWORKER	16.02	
LABORER		
Asphalt Raker and Spreader	12.46 **	
Asphalt Screed/Jackman	14.33 **	
Carpenter Tender	12.88 **	
Cement Mason/Concrete Finisher Tender	12.54 **	
Common or General	10.20 **	
Guardrail/Fence Installer	12.87 **	
Pipelayer	12.17 **	
Traffic Signal/Lighting Installer	14.89 **	
PAINTER		
Bridge	24.57	
POWER EQUIPMENT OPERATORS		
Asphalt Broom Tractor	11.85 **	
Bulldozer Fine	17.04	
Bulldozer Rough	14.34 **	
Concrete Grinder/Groover	20.34	2.30
Crane Boom Trucks	20.54	
Crane Other	20.08	
Crane Rough/All-Terrain	20.67	
Drill Operator Rock	14.38 **	
Drill Operator Structure	21.14	
Excavator Fine	16.60	
Excavator Rough	14.00 **	
Grader/Blade Fine	18.47	
Grader/Blade Rough	14.62 **	
Loader 2 Cubic Yards or Less	13.76 **	
Loader Greater Than 2 Cubic Yards	14.14 **	
Material Transfer Vehicle (Shuttle Buggy)	15.18	
Mechanic	17.55	
Milling Machine	15.36	
Off-Road Hauler/Water Tanker	11.36 **	
Oiler/Greaser	13.55 **	

	Rates	Fringes
Pavement Marking Equipment	12.11 **	
Paver Asphalt	15.59	
Paver Concrete	18.20	
Roller Asphalt Breakdown	12.45 **	
Roller Asphalt Finish	13.85 **	
Roller Other	11.36 **	
Scraper Finish	12.71 **	
Scraper Rough	11.35 **	
Slip Form Machine	16.50	
Tack Truck/Distributor Operator	14.52 **	
TRUCK DRIVER		
GVWR of 26,000 Lbs or Less	11.12 **	
GVWR of 26,001 Lbs or Greater	12.37 **	

Welders – Receive rate prescribed for craft performing operation to which welding is incidental.

** Workers in this classification may be entitled to a higher minimum wage under Executive Order 14026 (\$15.00) or 13658 (\$11.25). Please see the Note at the top of the wage determination for more information.

Note: Executive Order (EO) 13706, Establishing Paid Sick Leave for Federal Contractors applies to all contracts subject to the Davis-Bacon Act for which the contract is awarded (and any solicitation was issued) on or after January 1, 2017. If this contract is covered by the EO, the contractor must provide employees with 1 hour of paid sick leave for every 30 hours they work, up to 56 hours of paid sick leave each year. Employees must be permitted to use paid sick leave for their own illness, injury or other health-related needs, including preventive care; to assist a family member (or person who is like family to the employee) who is ill, injured, or has other health-related needs, including preventive care; or for reasons resulting from, or to assist a family member (or person who is like family to the employee) who is a victim of, domestic violence, sexual assault, or stalking. Additional information on contractor requirements and worker protections under the EO is available at <https://www.dol.gov/agencies/whd/government-contracts>.

Unlisted classifications needed for work not included within the scope of the classifications listed may be added after award only as provided in the labor standards contract clauses (29 CFR 5.5(a)(1)(ii)).

The body of each wage determination lists the classification and wage rates that have been found to be prevailing for the cited type(s) of construction in the area covered by the wage determination. The classifications are listed in alphabetical order of "identifiers" that indicate whether the particular rate is a union rate (current union negotiated rate for local), a survey rate (weighted average rate) or a union average rate (weighted union average rate).

Union Rate Identifiers

A four letter classification abbreviation identifier enclosed in dotted lines beginning with characters other than "SU" or "UAVG" denotes that the union classification and rate were prevailing for that classification in the survey. Example: PLUM0198-005 07/01/2014. PLUM is an abbreviation identifier of the union which prevailed in the survey for this classification, which

in this example would be Plumbers. 0198 indicates the local union number or district council number where applicable, i.e., Plumbers Local 0198. The next number, 005 in the example, is an internal number used in processing the wage determination. 07/01/2014 is the effective date of the most current negotiated rate, which in this example is July 1, 2014.

Union prevailing wage rates are updated to reflect all rate changes in the collective bargaining agreement (CBA) governing this classification and rate.

Survey Rate Identifiers

Classifications listed under the "SU" identifier indicate that no one rate prevailed for this classification in the survey and the published rate is derived by computing a weighted average rate based on all the rates reported in the survey for that classification. As this weighted average rate includes all rates reported in the survey, it may include both union and non-union rates. Example: SULA2012-007 5/13/2014. SU indicates the rates are survey rates based on a weighted average calculation of rates and are not majority rates. LA indicates the State of Louisiana. 2012 is the year of survey on which these classifications and rates are based. The next number, 007 in the example, is an internal number used in producing the wage determination. 5/13/2014 indicates the survey completion date for the classifications and rates under that identifier.

Survey wage rates are not updated and remain in effect until a new survey is conducted.

Union Average Rate Identifiers

Classification(s) listed under the UAVG identifier indicate that no single majority rate prevailed for those classifications; however, 100% of the data reported for the classifications was union data. EXAMPLE: UAVG-OH-0010 08/29/2014. UAVG indicates that the rate is a weighted union average rate. OH indicates the state. The next number, 0010 in the example, is an internal number used in producing the wage determination. 08/29/2014 indicates the survey completion date for the classifications and rates under that identifier.

A UAVG rate will be updated once a year, usually in January of each year, to reflect a weighted average of the current negotiated/CBA rate of the union locals from which the rate is based.

WAGE DETERMINATION APPEALS PROCESS

1.) Has there been an initial decision in the matter? This can be:

- * an existing published wage determination
- * a survey underlying a wage determination
- * a Wage and Hour Division letter setting forth a position on a wage determination matter
- * a conformance (additional classification and rate) ruling

On survey related matters, initial contact, including requests for summaries of surveys, should be with the Wage and Hour National Office because National Office has responsibility for the David-Bacon survey program. If the response from this initial contact is not satisfactory, then the process described in 2.) and 3.) should be followed.

With regard to any other matter not yet ripe for the formal process described here, initial contact should be with the Branch of Construction Wage Determinations. Write to:

Branch of Construction Wage Determinations
Wage and Hour Division
U. S. Department of Labor
200 Constitution Avenue, N.W.
Washington, D.C. 20210

- 2.) If the answer to the question in 1.) is yes, then an interested party (those affected by the action) can request review and reconsideration from the Wage and Hour Administrator (See 29 CFR Part 1.8 and 29 CFR Part 7). Write to:

Wage and Hour Administrator
U.S. Department of Labor
200 Constitution Avenue, N.W.
Washington, D.C. 20210

The request should be accompanied by a full statement of the interested party's position and by any information (wage payment data, project description, area practice material, etc.) that the requestor considers relevant to the issue.

- 3.) If the decision of the Administrator is not favorable, an interested party may appeal directly to the Administrative Review Board (formerly the Wage Appeals Board). Write to:

Administrative Review Board
U.S. Department of Labor
200 Constitution Avenue, N.W.
Washington, D.C. 20210

- 4.) All decisions by the Administrative Review Board are final.

END OF GENERAL DECISION

STANDARD SPECIAL PROVISION
MINIMUM WAGES
GENERAL DECISION NC20220091 02/25/2022 NC91

Z-091

Date: February 25, 2022

General Decision Number: NC20220091 02/25/2022 NC91

Superseded General Decision Numbers: NC20210091

State: North Carolina

Construction Type: HIGHWAY

COUNTIES:

Beaufort	Granville	Pasquotank
Bertie	Halifax	Perquimans
Bladen	Harnett	Robeson
Camden	Hertford	Sampson
Carteret	Hyde	Scotland
Chowan	Jones	Tyrrell
Columbus	Lenoir	Vance
Craven	Martin	Warren
Dare	Northampton	Washington
Duplin	Pamlico	Wilson
Gates		

HIGHWAY CONSTRUCTION PROJECTS (excluding tunnels, building structures in rest area projects & railroad construction; bascule, suspension & spandrel arch bridges designed for commercial navigation, bridges involving marine construction; and other major bridges).

Note: Contracts subject to the Davis-Bacon Act are generally required to pay at least the applicable minimum wage rate required under Executive Order 14026 or Executive Order 13658. Please note that these Executive Orders apply to covered contracts entered into by the federal government that are subject to the Davis-Bacon Act itself, but do not apply to contracts subject only to the Davis-Bacon Related Acts, including those set forth at 29 CFR 5.1(a)(2)-(60).

If the contract is entered into on or after January 30, 2022, or the contract is renewed or extended (e.g., an option is exercised) on or after January 30, 2022:	Executive Order 14026 generally applies to the contract. The contractor must pay all covered workers at least \$15.00 per hour (or the applicable wage rate listed on this wage determination, if it is higher) for all hours spent performing on that contract in 2022.
If the contract was awarded on or between January 1, 2015 and January 29, 2022, and the contract is not renewed or extended on or after January 30, 2022:	Executive Order 13658 generally applies to the contract. The contractor must pay all covered workers at least \$11.25 per hour (or the applicable wage rate listed on this wage determination, if it is higher) for all hours spent performing on that contract in 2022.

The applicable Executive Order minimum wage rate will be adjusted annually. If this contract is covered by one of the Executive Orders and a classification considered necessary for performance of work on the contract does not appear on this wage determination, the contractor must still submit a conformance request.

Additional information on contractor requirements and worker protections under the Executive Orders is available at <https://www.dol.gov/agencies/whd/government-contracts>.

Modification Number	Publication Date
0	01/07/2022
1	02/25/2022

SUNC2014-006 11/17/2014

	Rates	Fringes
BLASTER	21.85	
CARPENTER	13.72 **	
CEMENT MASON/CONCRETE FINISHER	14.26 **	
ELECTRICIAN		
Electrician	18.69	2.66
Telecommunications Technician	14.72 **	1.67
IRONWORKER	16.32	
LABORER		
Asphalt Raker and Spreader	12.42 **	
Asphalt Screed/Jackman	13.48 **	
Carpenter Tender	10.85 **	
Cement Mason/Concrete Finisher Tender	11.35 **	
Common or General	10.12 **	
Guardrail/Fence Installer	13.39 **	
Pipelayer	13.31 **	
Traffic Signal/Lighting Installer	16.88	
PAINTER		
Bridge	19.62	
POWER EQUIPMENT OPERATORS		
Asphalt Broom Tractor	13.28 **	

	Rates	Fringes
Bulldozer Fine	18.46	
Bulldozer Rough	14.09 **	
Concrete Grinder/Groover	24.66	
Crane Boom Trucks	17.25	
Crane Other	21.48	
Crane Rough/All-Terrain	19.00	
Drill Operator Rock	15.43	1.61
Drill Operator Structure	19.12	
Excavator Fine	17.61	
Excavator Rough	12.99 **	
Grader/Blade Fine	16.73	
Grader/Blade Rough	15.28	
Loader 2 Cubic Yards or Less	10.28 **	
Loader Greater Than 2 Cubic Yards	13.58 **	
Material Transfer Vehicle (Shuttle Buggy)	17.39	
Mechanic	18.63	
Milling Machine	14.38 **	
Off-Road Hauler/Water Tanker	9.30 **	
Oiler/Greaser	13.45 **	
Pavement Marking Equipment	11.87 **	
Paver Asphalt	15.53	
Roller Asphalt Breakdown	12.13 **	
Roller Asphalt Finish	13.65 **	
Roller Other	10.48 **	
Scraper Finish	13.98 **	
Scraper Rough	10.17 **	
Slip Form Machine	19.29	
Tack Truck/Distributor Operator	14.56 **	
TRUCK DRIVER		
GVWR of 26,000 Lbs or Less	10.35 **	
GVWR of 26,001 Lbs or Greater	12.04 **	

Welders – Receive rate prescribed for craft performing operation to which welding is incidental.

** Workers in this classification may be entitled to a higher minimum wage under Executive Order 14026 (\$15.00) or 13658 (\$11.25). Please see the Note at the top of the wage determination for more information.

Note: Executive Order (EO) 13706, Establishing Paid Sick Leave for Federal Contractors applies to all contracts subject to the Davis-Bacon Act for which the contract is awarded (and any solicitation was issued) on or after January 1, 2017. If this contract is covered by the EO, the contractor must provide employees with 1 hour of paid sick leave for every 30 hours they work, up to 56 hours of paid sick leave each year. Employees must be permitted to use paid sick leave for their own illness, injury or other health-related needs, including preventive care; to assist a family member (or person who is like family to the employee) who is ill, injured, or has other health-related needs, including preventive care; or for reasons resulting from, or to assist a family member (or person who is like family to the employee) who is a victim of, domestic violence, sexual assault, or stalking. Additional information on contractor requirements and worker protections under the EO is available at <https://www.dol.gov/agencies/whd/government-contracts>.

Unlisted classifications needed for work not included within the scope of the classifications listed may be added after award only as provided in the labor standards contract clauses (29 CFR 5.5(a)(1)(ii)).

The body of each wage determination lists the classification and wage rates that have been found to be prevailing for the cited type(s) of construction in the area covered by the wage determination. The classifications are listed in alphabetical order of "identifiers" that indicate whether the particular rate is a union rate (current union negotiated rate for local), a survey rate (weighted average rate) or a union average rate (weighted union average rate).

Union Rate Identifiers

A four letter classification abbreviation identifier enclosed in dotted lines beginning with characters other than "SU" or "UAVG" denotes that the union classification and rate were prevailing for that classification in the survey. Example: PLUM0198-005 07/01/2014. PLUM is an abbreviation identifier of the union which prevailed in the survey for this classification, which in this example would be Plumbers. 0198 indicates the local union number or district council number where applicable, i.e., Plumbers Local 0198. The next number, 005 in the example, is an internal number used in processing the wage determination. 07/01/2014 is the effective date of the most current negotiated rate, which in this example is July 1, 2014.

Union prevailing wage rates are updated to reflect all rate changes in the collective bargaining agreement (CBA) governing this classification and rate.

Survey Rate Identifiers

Classifications listed under the "SU" identifier indicate that no one rate prevailed for this classification in the survey and the published rate is derived by computing a weighted average rate based on all the rates reported in the survey for that classification. As this weighted average rate includes all rates reported in the survey, it may include both union and non-union rates. Example: SULA2012-007 5/13/2014. SU indicates the rates are survey rates based on a weighted average calculation of rates and are not majority rates. LA indicates the State of Louisiana. 2012 is the year of survey on which these classifications and rates are based. The next number, 007 in the example, is an internal number used in producing the wage determination. 5/13/2014 indicates the survey completion date for the classifications and rates under that identifier.

Survey wage rates are not updated and remain in effect until a new survey is conducted.

Union Average Rate Identifiers

Classification(s) listed under the UAVG identifier indicate that no single majority rate prevailed for those classifications; however, 100% of the data reported for the classifications was union data. EXAMPLE: UAVG-OH-0010 08/29/2014. UAVG indicates that the rate is a weighted union average rate. OH indicates the state. The next number, 0010 in the example, is an internal number used in producing the wage determination. 08/29/2014 indicates the survey completion date for the classifications and rates under that identifier.

A UAVG rate will be updated once a year, usually in January of each year, to reflect a weighted average of the current negotiated/CBA rate of the union locals from which the rate is based.

WAGE DETERMINATION APPEALS PROCESS

1.) Has there been an initial decision in the matter? This can be:

- * an existing published wage determination
- * a survey underlying a wage determination
- * a Wage and Hour Division letter setting forth a position on a wage determination matter
- * a conformance (additional classification and rate) ruling

On survey related matters, initial contact, including requests for summaries of surveys, should be with the Wage and Hour National Office because National Office has responsibility for the David-Bacon survey program. If the response from this initial contact is not satisfactory, then the process described in 2.) and 3.) should be followed.

With regard to any other matter not yet ripe for the formal process described here, initial contact should be with the Branch of Construction Wage Determinations. Write to:

Branch of Construction Wage Determinations
Wage and Hour Division
U. S. Department of Labor
200 Constitution Avenue, N.W.
Washington, D.C. 20210

2.) If the answer to the question in 1.) is yes, then an interested party (those affected by the action) can request review and reconsideration from the Wage and Hour Administrator (See 29 CFR Part 1.8 and 29 CFR Part 7). Write to:

Wage and Hour Administrator
U.S. Department of Labor
200 Constitution Avenue, N.W.
Washington, D.C. 20210

The request should be accompanied by a full statement of the interested party's position and by any information (wage payment data, project description, area practice material, etc.) that the requestor considers relevant to the issue.

3.) If the decision of the Administrator is not favorable, an interested party may appeal directly to the Administrative Review Board (formerly the Wage Appeals Board). Write to:

Administrative Review Board
U.S. Department of Labor
200 Constitution Avenue, N.W.
Washington, D.C. 20210

4.) All decisions by the Administrative Review Board are final.

END OF GENERAL DECISION

LISTING OF DBE SUBCONTRACTORS

Sheet of

Firm Name and Address	Item No.	Item Description	* Agreed upon Unit Price	** Dollar Volume of Item
Name Address				
Name Address				
Name Address				
Name Address				
Name Address				
Name Address				
Name Address				

* The Dollar Volume shown in this column shall be the Actual Price Agreed Upon by the Prime Contractor and the DBE subcontractor, and these prices will be used to determine the percentage of the DBE participation in the contract.

** Dollar Volume of DBE Subcontractor Percentage of Total Contract Bid Price:

If firm is a Material Supplier Only, show Dollar Volume as 60% of Agreed Upon Amount from Letter of Intent.

If firm is a Manufacturer, show Dollar Volume as 100% of Agreed Upon Amount from Letter of Intent.

LISTING OF DBE SUBCONTRACTORS

Sheet of

Firm Name and Address	Item No.	Item Description	* Agreed upon Unit Price	** Dollar Volume of Item
Name Address				
Name Address				
Name Address				
Name Address				
Name Address				

**** Dollar Volume of DBE Subcontractor \$ _____**

Percentage of Total Contract Bid Price _____%

*** The Dollar Volume shown in this column shall be the Actual Price Agreed Upon by the Prime Contractor and the DBE subcontractor, and these prices will be used to determine the percentage of the DBE participation in the contract.**

**** Dollar Volume of DBE Subcontractor Percentage of Total Contract Bid Price:
 If firm is a Material Supplier Only, show Dollar Volume as 60% of Agreed Upon Amount from Letter of Intent.
 If firm is a Manufacturer, show Dollar Volume as 100% of Agreed Upon Amount from Letter of Intent.**

ADDENDUM(S)

ADDENDUM #1

I, _____
(SIGNATURE)

representing _____

Acknowledge receipt of Addendum #1.

ADDENDUM #2

I, _____
(SIGNATURE)

representing _____

Acknowledge receipt of Addendum #2.

ADDENDUM #3

I, _____
(SIGNATURE)

representing _____

Acknowledge receipt of Addendum #3.

AWARD LIMITS ON MULTIPLE PROJECTS

It is the desire of the Proposer to be awarded contracts, the value of which will not exceed a total of \$ _____, for those projects indicated below on which bids are being opened on the same date as shown in the Proposal Form. Individual projects shall be indicated by placing the project number and county in the appropriate place below. Projects not selected will not be subject to an award limit.

(Project Number)

(County)

(Project Number)

(County)

(Project Number)

(County)

(Project Number)

(County)

*If a Proposer desires to limit the total amount of work awarded to him in this letting, he shall state such limit in the space provided above in the second line of this form.

It is agreed that in the event that I am (we are) the successful bidder on indicated projects, the total value of which is more than the above stipulated award limits, the Board of Transportation will award me (us) projects from among those indicated which have a total value not exceeding the award limit and which will result in the best advantage to the Department of Transportation.

**Signature of Authorized Person

**Only those persons authorized to sign bids under the provisions of Article 102-8, Item 7, shall be authorized to sign this form.

EXECUTION OF BID

NON-COLLUSION, DEBARMENT AND GIFT BAN CERTIFICATION

CORPORATION

The prequalified bidder, declares (or certifies, verifies, or states) under penalty of perjury under the laws of the United States that neither he, nor any official, agent or employee has entered into any agreement, participated in any collusion, or otherwise taken any action which is in restraint of free competitive bidding in connection with any bid or contract, that the prequalified bidder has not been convicted of violating *N.C.G.S. §133-24* within the last three years, and that the prequalified bidder intends to do the work with his own bona fide employees or subcontractors and will not bid for the benefit of another contractor.

By submitting this non-collusion, debarment and gift ban certification, the Contractor is attesting his status under penalty of perjury under the laws of the United States in accordance with the Debarment Certification attached, provided that the Debarment Certification also includes any required statements concerning exceptions that are applicable.

N.C.G.S. §133-32 and Executive Order 24 prohibit the offer to, or acceptance by, any State Employee of any gift from anyone with a contract with the State, or from any person seeking to do business with the State. By execution of any response in this procurement, you attest, for your entire organization and its employees or agents, that you are not aware that any such gift has been offered, accepted, or promised by any employees of your organization.

SIGNATURE OF PREQUALIFIED BIDDER

Full name of Corporation

Address as Prequalified

Attest _____
Secretary/Assistant Secretary
(Select appropriate title)

By _____
President/Vice President/Assistant Vice President
(Select appropriate title)

Print or type Signer's name

Print or type Signer's name

CORPORATE SEAL

NON-COLLUSION, DEBARMENT AND GIFT BAN CERTIFICATION

PARTNERSHIP

The prequalified bidder, declares (or certifies, verifies, or states) under penalty of perjury under the laws of the United States that neither he, nor any official, agent or employee has entered into any agreement, participated in any collusion, or otherwise taken any action which is in restraint of free competitive bidding in connection with any bid or contract, that the prequalified bidder has not been convicted of violating *N.C.G.S. § 133-24* within the last three years, and that the prequalified bidder intends to do the work with its own bona fide employees or subcontractors and will not bid for the benefit of another contractor.

By submitting this non-collusion, debarment and gift ban certification, the Contractor is attesting his status under penalty of perjury under the laws of the United States in accordance with the Debarment Certification attached, provided that the Debarment Certification also includes any required statements concerning exceptions that are applicable.

N.C.G.S. § 133-32 and Executive Order 24 prohibit the offer to, or acceptance by, any State Employee of any gift from anyone with a contract with the State, or from any person seeking to do business with the State. By execution of any response in this procurement, you attest, for your entire organization and its employees or agents, that you are not aware that any such gift has been offered, accepted, or promised by any employees of your organization.

SIGNATURE OF PREQUALIFIED BIDDER

Full Name of
Partnership

Address as
Prequalified

Signature of Witness

Signature of Partner

Print or Type Signer's Name

Print or Type Signer's Name

NON-COLLUSION, DEBARMENT AND GIFT BAN CERTIFICATION

LIMITED LIABILITY COMPANY

The prequalified bidder, declares (or certifies, verifies, or states) under penalty of perjury under the laws of the United States that neither he, nor any official, agent or employee has entered into any agreement, participated in any collusion, or otherwise taken any action which is in restraint of free competitive bidding in connection with any bid or contract, that the prequalified bidder has not been convicted of violating *N.C.G.S. § 133-24* within the last three years, and that the prequalified bidder intends to do the work with its own bona fide employees or subcontractors and will not bid for the benefit of another contractor.

By submitting this non-collusion, debarment and gift ban certification, the Contractor is attesting his status under penalty of perjury under the laws of the United States in accordance with the Debarment Certification attached, provided that the Debarment Certification also includes any required statements concerning exceptions that are applicable.

N.C.G.S. § 133-32 and Executive Order 24 prohibit the offer to, or acceptance by, any State Employee of any gift from anyone with a contract with the State, or from any person seeking to do business with the State. By execution of any response in this procurement, you attest, for your entire organization and its employees or agents, that you are not aware that any such gift has been offered, accepted, or promised by any employees of your organization.

SIGNATURE OF PREQUALIFIED BIDDER

Full Name of Firm

Address as Prequalified

Signature of Witness

Signature of Member/Manager/Authorized Agent
(Select appropriate Title)

Print or Type Signer's Name

Print or Type Signer's Name

NON-COLLUSION, DEBARMENT AND GIFT BAN CERTIFICATION

JOINT VENTURE (2) or (3)

The prequalified bidder, declares (or certifies, verifies, or states) under penalty of perjury under the laws of the United States that neither he, nor any official, agent or employee has entered into any agreement, participated in any collusion, or otherwise taken any action which is in restraint of free competitive bidding in connection with any bid or contract, that the prequalified bidder has not been convicted of violating *N.C.G.S. § 133-24* within the last three years, and that the prequalified bidder intends to do the work with its own bona fide employees or subcontractors and will not bid for the benefit of another contractor.

By submitting this non-collusion, debarment and gift ban certification, the Contractor is attesting his status under penalty of perjury under the laws of the United States in accordance with the Debarment Certification attached, provided that the Debarment Certification also includes any required statements concerning exceptions that are applicable.

N.C.G.S. § 133-32 and Executive Order 24 prohibit the offer to, or acceptance by, any State Employee of any gift from anyone with a contract with the State, or from any person seeking to do business with the State. By execution of any response in this procurement, you attest, for your entire organization and its employees or agents, that you are not aware that any such gift has been offered, accepted, or promised by any employees of your organization.

SIGNATURE OF PREQUALIFIED BIDDER

Instructions: **2 Joint Venturers** Fill in lines (1), (2) and (3) and execute. **3 Joint Venturers** Fill in lines (1), (2), (3) and (4) and execute. On Line (1), fill in the name of the Joint Venture Company. On Line (2), fill in the name of one of the joint venturers and execute below in the appropriate manner. On Line (3), print or type the name of the other joint venturer and execute below in the appropriate manner. On Line (4), fill in the name of the third joint venturer, if applicable and execute below in the appropriate manner.

(1) _____
Name of Joint Venture

(2) _____
Name of Contractor

Address as Prequalified

Signature of Witness or Attest

 BY _____
Signature of Contractor

Print or Type Signer's Name

Print or Type Signer's Name

If Corporation, affix Corporate Seal AND

(3) _____
Name of Contractor

Address as Prequalified

Signature of Witness or Attest

 BY _____
Signature of Contractor

Print or Type Signer's Name

Print or Type Signer's Name

If Corporation, affix Corporate Seal AND

(4) _____
Name of Contractor

Address as Prequalified

Signature of Witness or Attest

 BY _____
Signature of Contractor

Print or Type Signer's Name

Print or Type Signer's Name

If Corporation, affix Corporate Seal

**NON-COLLUSION, DEBARMENT AND GIFT BAN CERTIFICATION
INDIVIDUAL DOING BUSINESS UNDER A FIRM NAME**

The prequalified bidder, declares (or certifies, verifies, or states) under penalty of perjury under the laws of the United States that neither he, nor any official, agent or employee has entered into any agreement, participated in any collusion, or otherwise taken any action which is in restraint of free competitive bidding in connection with any bid or contract, that the prequalified bidder has not been convicted of violating *N.C.G.S. § 133-24* within the last three years, and that the prequalified bidder intends to do the work with its own bona fide employees or subcontractors and will not bid for the benefit of another contractor.

By submitting this non-collusion, debarment and gift ban certification, the Contractor is attesting his status under penalty of perjury under the laws of the United States in accordance with the Debarment Certification attached, provided that the Debarment Certification also includes any required statements concerning exceptions that are applicable.

N.C.G.S. § 133-32 and Executive Order 24 prohibit the offer to, or acceptance by, any State Employee of any gift from anyone with a contract with the State, or from any person seeking to do business with the State. By execution of any response in this procurement, you attest, for your entire organization and its employees or agents, that you are not aware that any such gift has been offered, accepted, or promised by any employees of your organization.

SIGNATURE OF PREQUALIFIED BIDDER

Name of Prequalified Bidder

_____ Individual Name

Trading and Doing Business As

_____ Full name of Firm

_____ Address as Prequalified

Signature of Witness

Signature of Prequalified Bidder, Individual

Print or Type Signer's Name

Print or Type Signer's Name

NON-COLLUSION, DEBARMENT AND GIFT BAN CERTIFICATION

INDIVIDUAL DOING BUSINESS IN HIS OWN NAME

The prequalified bidder, declares (or certifies, verifies, or states) under penalty of perjury under the laws of the United States that neither he, nor any official, agent or employee has entered into any agreement, participated in any collusion, or otherwise taken any action which is in restraint of free competitive bidding in connection with any bid or contract, that the prequalified bidder has not been convicted of violating *N.C.G.S. § 133-24* within the last three years, and that the prequalified bidder intends to do the work with its own bona fide employees or subcontractors and will not bid for the benefit of another contractor.

By submitting this non-collusion, debarment and gift ban certification, the Contractor is attesting his status under penalty of perjury under the laws of the United States in accordance with the Debarment Certification attached, provided that the Debarment Certification also includes any required statements concerning exceptions that are applicable.

N.C.G.S. § 133-32 and Executive Order 24 prohibit the offer to, or acceptance by, any State Employee of any gift from anyone with a contract with the State, or from any person seeking to do business with the State. By execution of any response in this procurement, you attest, for your entire organization and its employees or agents, that you are not aware that any such gift has been offered, accepted, or promised by any employees of your organization.

SIGNATURE OF PREQUALIFIED BIDDER

Name of Prequalified Bidder _____
Print or Type Name

Address as Prequalified

Signature of Prequalified Bidder, Individually

Print or type Signer's Name

Signature of Witness

Print or type Signer's name

DEBARMENT CERTIFICATION

Conditions for certification:

1. The prequalified bidder shall provide immediate written notice to the Department if at any time the bidder learns that his certification was erroneous when he submitted his debarment certification or explanation filed with the Department, or has become erroneous because of changed circumstances.
2. The terms *covered transaction, debarred, suspended, ineligible, lower tier covered transaction, participant, person, primary covered transaction, principal, proposal, and voluntarily excluded*, as used in this provision, have the meanings set out in the Definitions and Coverage sections of the rules implementing Executive Order 12549. A copy of the Federal Rules requiring this certification and detailing the definitions and coverages may be obtained from the Contract Officer of the Department.
3. The prequalified bidder agrees by submitting this form, that he will not knowingly enter into any lower tier covered transaction with a person who is debarred, suspended, declared ineligible, or voluntarily excluded from participation in NCDOT contracts, unless authorized by the Department.
4. For Federal Aid projects, the prequalified bidder further agrees that by submitting this form he will include the Federal-Aid Provision titled *Required Contract Provisions Federal-Aid Construction Contract (Form FHWA PR 1273)* provided by the Department, without subsequent modification, in all lower tier covered transactions.
5. The prequalified bidder may rely upon a certification of a participant in a lower tier covered transaction that he is not debarred, suspended, ineligible, or voluntarily excluded from the covered transaction, unless he knows that the certification is erroneous. The bidder may decide the method and frequency by which he will determine the eligibility of his subcontractors.
6. Nothing contained in the foregoing shall be construed to require establishment of a system of records in order to render in good faith the certification required by this provision. The knowledge and information of a participant is not required to exceed that which is normally possessed by a prudent person in the ordinary course of business dealings.
7. Except as authorized in paragraph 6 herein, the Department may terminate any contract if the bidder knowingly enters into a lower tier covered transaction with a person who is suspended, debarred, ineligible, or voluntarily excluded from participation in this transaction, in addition to other remedies available by the Federal Government.

DEBARMENT CERTIFICATION

The prequalified bidder certifies to the best of his knowledge and belief, that he and his principals:

- a. Are not presently debarred, suspended, proposed for debarment, declared ineligible, or voluntarily excluded from covered transactions by any Federal department or agency;
- b. Have not within a three-year period preceding this proposal been convicted of or had a civil judgment rendered against them for commission of fraud or a criminal offense in connection with obtaining, attempting to obtain, or performing a public (Federal, State or local) transaction or contract under a public transaction; violation of Federal or State antitrust statutes or commission of embezzlement, theft, forgery, bribery, falsification or destruction of records; making false statements; or receiving stolen property;
- c. Are not presently indicted for or otherwise criminally or civilly charged by a governmental entity (Federal, State or local) with commission of any of the offenses enumerated in paragraph b. of this certification; and
- d. Have not within a three-year period preceding this proposal had one or more public transactions (Federal, State or local) terminated for cause or default.
- e. Will submit a revised Debarment Certification immediately if his status changes and will show in his bid proposal an explanation for the change in status.

If the prequalified bidder cannot certify that he is not debarred, he shall provide an explanation with this submittal. An explanation will not necessarily result in denial of participation in a contract.

Failure to submit a non-collusion and debarment certification will result in the prequalified bidder's bid being considered non-responsive.

Check here if an explanation is attached to this certification.

North Carolina Department of Transportation

PURCHASE ORDER CONTRACT BID FORM

WBS Number: 3.1031SM, 3.1067SM, 3.1071SM, 3.1082SM, etc.

Signal & ITS Device Maintenance in Duplin, Onslow, Pender, Sampson, Brunswick & New Hanover Counties

ITEM	DESC	SECT	DESCRIPTION	QTY	UNIT	UNIT PRICE	AMOUNT BID
1	0000910000-N	SP	LABOR ON AN 'AS NEEDED BASIS"	25	HR		
2	0000915000-N	SP	EMERGENCY MOBILIZATION	5	EA		
3	2591000000-E	848	4" CONCRETE SIDEWALK	25	SY		
4	4450000000-N	1150	FLAGGER	500	HR		
5	4600000000-N	SP	FULL LANE CLOSURE	25	EA		
6	5045000000-N	1404	LIGHT STANDARD TYPE MTL5 45' SA 6'	5	EA		
7	5125000000-E	1407	ELECTRICAL SERVICE LATERAL #2	500	LF		
8	5175000000-E	1410	3 #6 W/G FEEDER CIRCUIT	1000	LF		
9	5270000000-N	SP	STANDARD LIGHT EMITTING DIODE (LED) LUMINAIRE	5	EA		
10	5270000000-N	SP	BREAKAWAY FUSE HOLDER	5	EA		
11	6000000000-E	1605	TEMPORARY SILT FENCE	250	LF		
12	7000000000-E	1705	PEDESTRIAN SIGNAL HEAD (16", 1 SECTION)	15	EA		
13	7060000000-E	1705	SIGNAL CABLE (16-4)	2,500	LF		
14	7060000000-E	1705	SIGNAL CABLE (16-7)	10,000	LF		
15	7120000000-E	1705	VEHICLE SIGNAL HEAD (12", 3 SECTION)	50	EA		
16	7132000000-E	1705	VEHICLE SIGNAL HEAD (12", 4 SECTION)	20	EA		
17	7144000000-E	1705	VEHICLE SIGNAL HEAD (12", 5 SECTION)	10	EA		
18	7180000000-N	1706	BACKING PLATES	50	EA		
19	7216000000-N	1705	MODIFY EXISTING VEHICLE SIGNALHEAD	5	EA		
20	7252000000-E	1710	MESSENGER CABLE (1/4")	1,000	LF		
21	7264000000-E	1710	MESSENGER CABLE (3/8")	2,500	LF		
22	7279000000-E	1715	TRACER WIRE	1,000	LF		
23	7288000000-E	1715	PAVED TRENCHING (2"-4" PVC CONDUIT)	250	LF		
24	7300000000-E	1715	UNPAVED TRENCHING (2"-4" PVC CONDUIT)	1,500	LF		
25	7301000000-E	1715	DIRECTIONAL DRILL (2"-4" PVC CONDUIT)	3,000	LF		
26	7324000000-N	1716	JUNCTION BOX (STANDARD SIZE)	25	EA		
27	7348000000-N	1716	JUNCTION BOX (OVER-SIZED, HEAVY DUTY)	10	EA		
28	7360000000-N	1720	WOOD POLE (35')	8	EA		
29	7360000000-N	1720	WOOD POLE (40')	8	EA		

ITEM	DESC	SECT	DESCRIPTION	QTY	UNIT	UNIT PRICE	AMOUNT BID
30	7360000000-N	1720	WOOD POLE (45')	5	EA		
31	7360000000-N	1720	WOOD POLE (55')	5	EA		
32	7372000000-N	1721	GUY ASSEMBLY	25	EA		
33	7372000000-N	1721	SIDEWALK GUY ASSEMBLY	5	EA		
34	7408000000-E	1722	1" RISER WITH WEATHERHEAD	15	EA		
35	7420000000-E	1722	2" RISER WITH WEATHERHEAD	30	EA		
36	7444000000-E	1725	INDUCTIVE LOOP SAWCUT	6,000	LF		
37	7456000000-E	1726	LEAD-IN CABLE (1 PAIR)	15,000	LF		
38	7481000000-N	SP	SITE SURVEY	10	EA		
39	7516000000-E	1730	COMMUNICATIONS CABLE (12 SMFO FIBER)	2,500	LF		
40	7540000000-N	1731	SPLICE ENCLOSURE	5	EA		
41	7552000000-N	1731	INTERCONNECT CENTER	5	EA		
42	7564000000-N	1732	FIBER-OPTIC TRANSCEIVER, DROP & REPEAT	5	EA		
43	7564100000-N	1732	FIBER-OPTIC TRANSCEIVER, SELF-HEALING RING	5	EA		
44	7566000000-N	1733	DELINEATOR MARKER	10	EA		
45	7575142000-N	1736	900MHZ SERIAL/ETHERNET SPREAD SPECTRUM RADIO	5	EA		
46	7575142200-N	SP	NEW ELECTRICAL SERVICE	5	EA		
47	7575180000-N	1735	CABLE TRANSFER	25	EA		
48	7576000000-N	SP	METAL STRAIN SIGNAL POLE	4	EA		
49	7588000000-N	SP	METAL POLE WITH SINGLE MAST ARM	8	EA		
50	7590000000-N	SP	METAL POLE WITH DUAL MAST ARM	4	EA		
51	7613000000-N	SP	SOIL TEST	16	EA		
52	7614100000-E	SP	DRILLED PIER FOUNDATION	100	CY		
53	7636000000-N	1745	SIGN FOR SIGNALS	15	EA		
54	7642100000-N	1743	TYPE I PEDESTAL WITH FOUNDATION	5	EA		
55	7642200000-N	1743	TYPE II PEDESTAL WITH FOUNDATION	5	EA		
56	7642300000-N	1743	TYPE III PEDESTAL WITH FOUNDATION	5	EA		
57	7684000000-N	1750	SIGNAL CABINET FOUNDATION	5	EA		
58	7686000000-N	1752	CONDUIT ENTRANCE INTO EXISTING FOUNDATION	5	EA		
59	7756000000-N	1751	CONTROLLER WITH CABINET (TYPE 2070L, BASE MOUNTED)	5	EA		
60	7768000000-N	1751	CONTROLLER WITH CABINET (TYPE 2070L, POLE MOUNTED)	5	EA		

ITEM	DESC	SECT	DESCRIPTION	QTY	UNIT	UNIT PRICE	AMOUNT BID
61	7901000000-N	1753	CABINET BASE EXTENDER	5	EA		
62	7912000000-N	1755	BEACON CONTROLLER ASSEMBLY & CABINET	5	EA		
63	7948000000-N	1757	TRAFFIC SIGNAL REMOVAL	25	EA		
64	7960000000-N	SP	METAL POLE FOUNDATION REMOVAL	5	EA		
65	7972000000-N	SP	METAL POLE REMOVAL	5	EA		
66	7980000000-N	SP	ETHERNET FIBER SWITCH UNIT	5	EA		
67	7980000000-N	SP	SOLAR POWER ASSEMBLY	5	EA		
68	7980000000-N	SP	DIGITAL HARDWARE VIDEO ENCODER	5	EA		
69	7980000000-N	SP	HIGH DEFINITION (HD) CCTV CAMERA EQUIPMENT	5	EA		
70	7980000000-N	SP	REPLACE PEDESTRIAN PUSH BUTTONS	10	EA		
71	7980000000-N	SP	ADJUST SPAN & GUY WIRE ATTACHMENTS	75	EA		
72	7980000000-N	SP	ANCHOR BOLTS	5	EA		
73	7980000000-N	SP	TEMPLATES	4	EA		
74	7980000000-N	SP	TRAFFIC SIGNAL WOOD POLE REMOVAL	10	EA		
75	7980000000-N	SP	VEHICLE SIGNAL HEAD REMOVAL	25	EA		
76	7980000000-N	SP	RADAR VEHICLE DETECTION SENSOR	5	EA		
77	7990000000-E	SP	RADAR VEHICLE DETECTION CABLE	1,000	LF		
78	7990000000-E	SP	MESSANGER CABLE REMOVAL	1,000	LF		
79	7990000000-E	SP	TRIPLEX (#6 GAUGE)	500	LF		

TOTAL BID FOR PROJECT:

CONTRACTOR _____

ADDRESS _____

Federal Identification Number _____

Contractors License Number _____

Authorized Agent _____

Title _____

Signature _____

Date _____

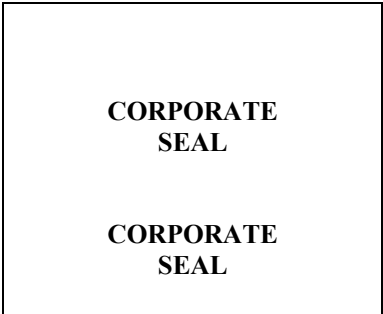

Witness _____ Title _____

Signature _____ Date _____

Point of Contact for Post-Bid Inquires (e.g., Letters of Intent, Insurance, Bonds, and Contract Execution)

Name _____

Email _____

Phone _____

**THIS SECTION TO BE COMPLETED BY
NORTH CAROLINA DEPARTMENT OF TRANSPORTATION**

This bid has been reviewed in accordance with Article 103-1 of the Standard Specifications for Roads and Structures 2018.

Reviewed by NCDOT _____ *Date* _____

Accepted by NCDOT _____ *Date* _____